



**dirinler**<sup>®</sup> since 1952

*Our expertise comes from our experience...since 1952...*



(((•))) dirinSmart 4.0





[www.dirinler.com.tr](http://www.dirinler.com.tr)

**since 1952...**

**Our expertise comes from our experience...**

# Time



1952

1955

1960

1970

1990

2000

1955 - **The First Universal Lathe Machine**  
Production in Turkey

1965 - 3 m **Universal Lathe Machine** Production

1966 - **The First** Participation to **Izmir Industrial Fair**

1967 - Production of **Casted Body Mechanical Press** with **Mechanical Clutch**

1974 - Establishment of **Dirinler Foundry**

1991 - **Dirinler** Moved to **Atatürk Organized Industrial Zone**

1995 - **The First CE Certified**  
Press Production in Turkey

2002 - Production of **PLC Controlled Table and Column Type Drilling Machine**

1962 - 1964 - **Carpentry Machine** Production

1966 - **The First Planing Machine**  
Production in Turkey

1973 - **Mechanical Press**  
Production with **Steel Body**

1978 - **The First Mechanical Press** with  
**Pneumatic Clutch** in Turkey

1993 - Production of **Hydraulic Press**

2000 - **Piston and Screw Air Compressor**  
Manufacturer **Lupamat** Joined to  
**Dirinler Group**

2001 - Production of **Oil Free Screw and Piston Air Compressor**

2004 - Production of **CNC Lethe Machines**



# Tunnel

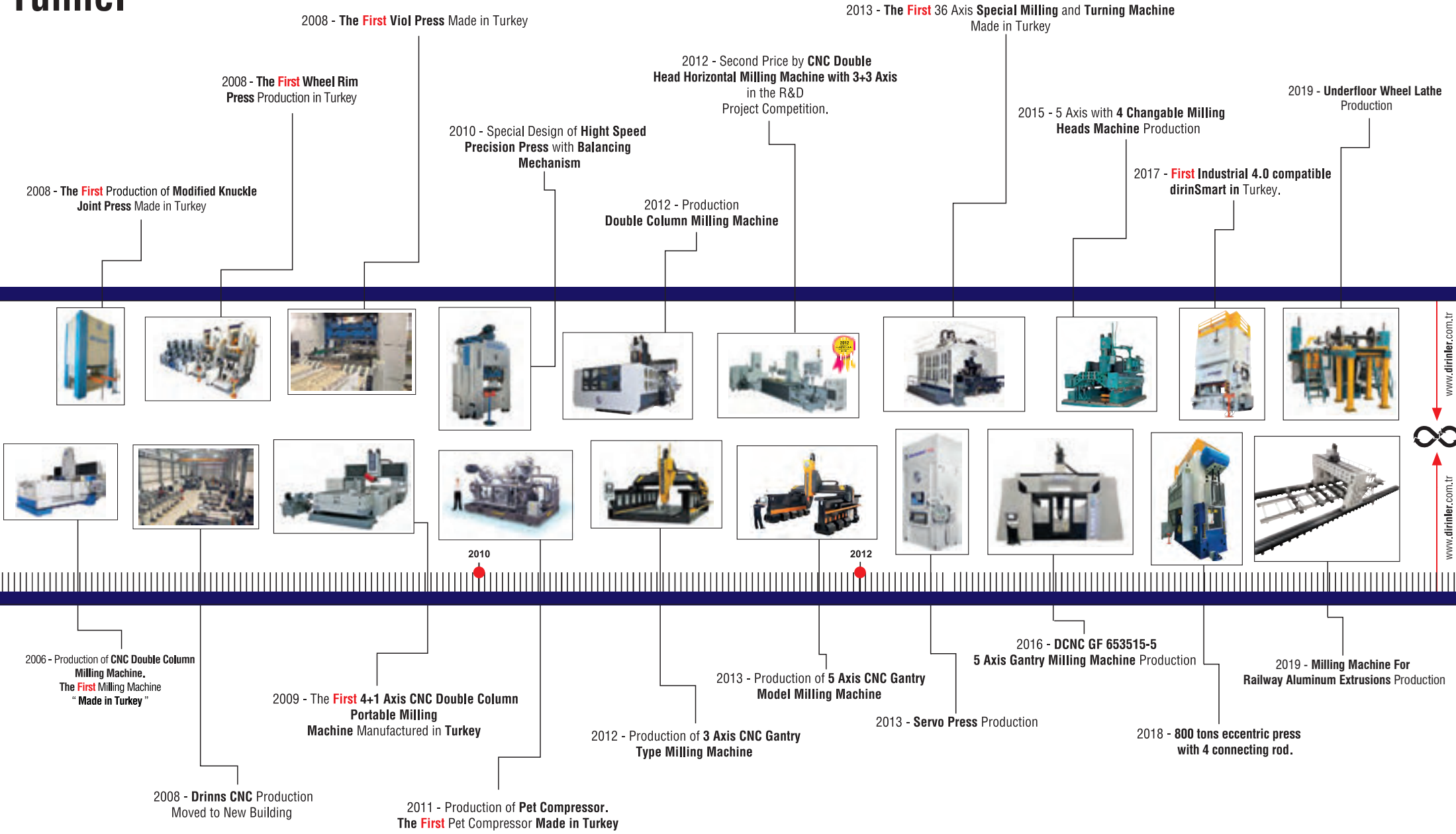



# Dirinler

## Dirinler Group





# Group



## DİRİLER MAKİNA SANAYİ VE TİCARET A.Ş.

Dirinler Makina was founded in 1952, Dirinler Makina is making metal forming presses in various sizes and dimensions. Among our product range eccentric, knuckle joint, link drive, servo and hydraulic presses are available in C-Frame as well as H-frame construction up to 2000 tons capacity. As a highly skilled manufacturer, Dirinler is performing rigorous production activities in its 18.000 sqm indoor facility which is sitting on 24.000 sqm total area. For the sake of customer satisfaction, we offer free investment consultancy services to our esteemed customers. Our vision is unlimited customer satisfaction and we offer "Product Liability Insurance"

For more information please visit: [www.dirinler.com.tr](http://www.dirinler.com.tr)



## DİRİLER DÖKÜM SANAYİ VE TİCARET A.Ş.

Dirinler Döküm was founded in 1974 for the production of cast iron parts. The company produces big and heavy parts up to 16 tons grey iron and 20 tons ductile iron in one piece for wind energy, ship building and heavy machinery industries, press molds for automotive industry, valves and pumps up to 4000 mm diameter with annual capacity of 20.000 tons in total 40.000 sqm area of which 20.000 sqm is indoor. Dirinler Döküm exports to many countries especially in Europe as rough or machined parts.

For more information please visit: [www.dirinlerdokum.com](http://www.dirinlerdokum.com)



## LUPAMAT MAKİNA SANAYİ A.Ş.

Lupamat was founded in 1968 in order to produce air compressors. The factory having activities in an area of 12.000 sqm of which 6.000sqm indoor, is producing reciprocating, screw air compressors and pet compressors under the brand of "Lupamat" and exports to many countries in the world especially in Europe and Middle East.

For more information please visit: [www.lupamat.com](http://www.lupamat.com)



## DİRİLER SANAYİ MAKİNALARI ENDÜSTRİ VE TİCARET A.Ş.

Our company was founded at 1983 and produces CNC Lathes, CNC Double Column Milling Machines, CNC Gantry type Milling Machines at 2500 sqm closed area since the year 2001. Our company also presents customized solutions with high quality products and reasonable price advantages by supplying special production with Drinns brand in line with the needs and expectations of the customers.

For more information please visit: [www.drinns.com.tr](http://www.drinns.com.tr)



## DİRİLER TURİZM, LİMAN İŞLETMECİLİĞİ, SEYAHAT, İNŞAAT, AKARYAKIT SANAYİ VE TİCARET A.Ş.

Dirinler Turizm started her activities at Levent Marina in 2010. Levent Marina of which operation rights was bought by Dirinler Döküm as a subsidiary to Dirinler Group, is the youngest company in the group. Levent Marina facilities are used for delivering port, technical services, fuel oil, and security services as well as shopping and entertainment center.

For more information please visit: [www.leventmarina.com.tr](http://www.leventmarina.com.tr)



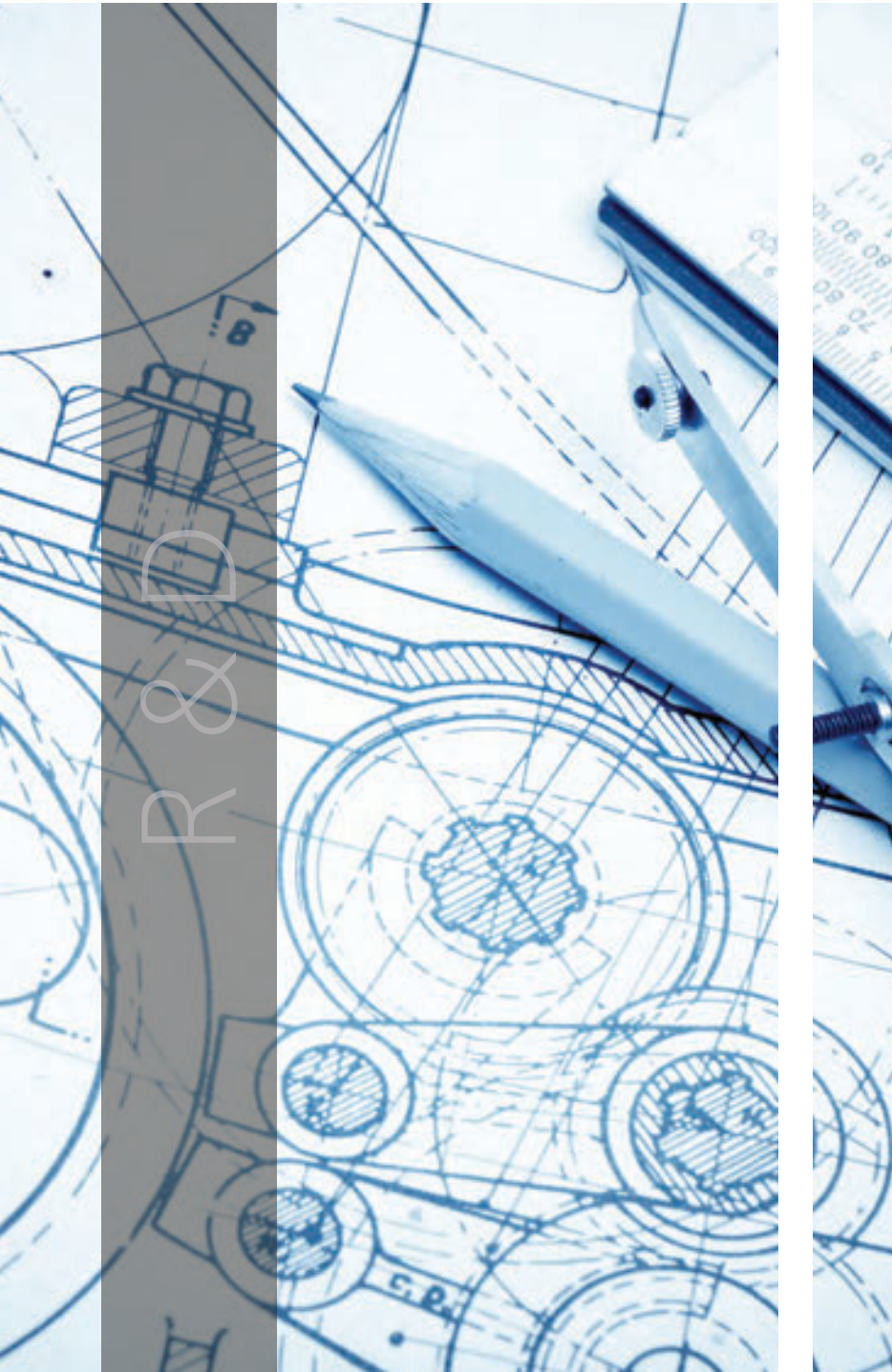

## Design

CAD Studies / Creo (Pro Engineer)

## Analysis;

CAE / Finite Elements Analysis

Kinematic Dynamic Analysis

## Special Programs

- Eccentric Press, Knuckle Joint Kinematic
- Dynamic Design Program
- Hydraulic Press Design Program
- 3 DOF Press Vibration Simulation Program
- Hydrodynamic Lubricated Bearing Design Program
- Gear Train Design Program

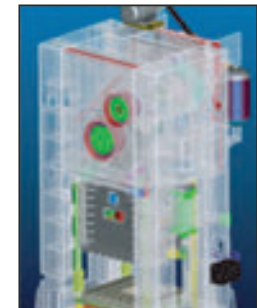
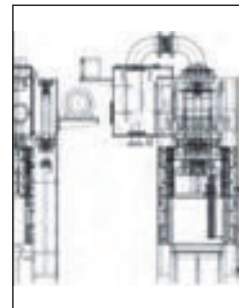
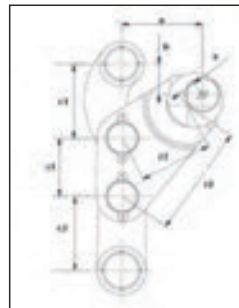



## Production Process

We manufacture according to today's high-tech sheet metal processing technology.

- Quality certificated materials,
- High qualified welding workmanship,
- CNC plasma cutting and CNC oxygen cutting,
- Straightening operations,
- Welding operations with robots,
- High precision body flexing analysis

## Stress Relieving by Vibration

Press bodies and components are subjected to stress relieving operations according to the method of stress relieving by vibration.



## Quality

- High precision component and body control via 3D measuring devices,
- Dimensional control via CMM according to world standards,
- Parallelism control under load,
- Measurement and shear test,
- High precision body flexing analysis,
- Loadcell ITC capacity control.

# Certificates;

All our machines are "CE" certified.



CERTIFICATE



AFTER SALES SERVICE





We are always ready to serve you on



basis.

All around the world

- We established  **dirinler<sup>GmbH</sup>** to be closer to our customers in Europe and to bring our R & D projects together with German engineering.
- We produced  **dirinSmart 4.0** with Industry 4.0 technology which can detect its own fault.
- We have increased our capacity up to 3000 tons.
- Our company which has the only R & D center in the sector supported by the Ministry of Science, Industry and Technology of Turkey will continue to be the Pioneer of innovations as **dirinler**

PRODUCTS

---





**C-type Eccentric Press**



**D-type Lamination Press**



**C-type Hydraulic Press**



**H-type Eccentric Press (Single Connecting Rod)**



**H-type Eccentric Press (Double Connecting Rod)**



**Knuckle Joint Form Press**



**H-type Hydraulic Press**



**Servo Press**

## Back Sided C Frame Eccentric Press (8 Guide Ram)

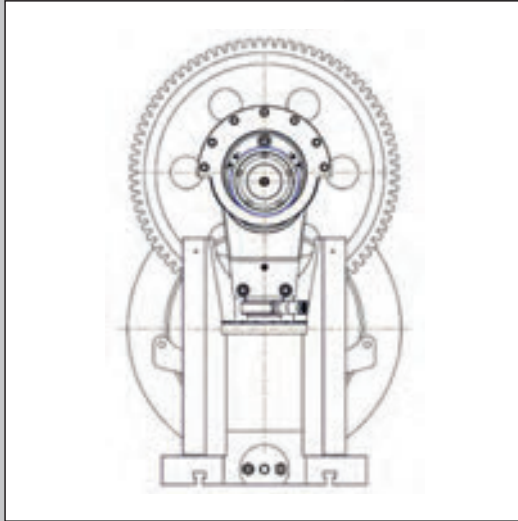

- Pneumatic clutch brake system
- Rigid body and ram
- User friendly ram adjustment
- 8 guide ram
- Helical, high quality gear system
- Spheroidal casting parts
- Mechanical or hydraulic overload safety system according to customer requests
- Automatic ram adjustment according to customer requests
- Automatic stroke adjustment for specified tonnages
- Ergonomic design
- Compliance with 2006-42 Machinery Directives



# Technical Specifications

Properties	Unit	CDCS 630 P81	CDCS 800 P81	CDCS 1100 P81	CDCS 1300 P81	CDCS 1600 P81	CDCS 2000 P81	CDCS 2500 P81
Capacity	tons	63	80	110	130	160	200	250
Rated tonnage height	mm	4,5	4,5	5	6	6	6	6
Max. shut die height	mm	350	385	385	385	480	440	500
Stroke distance	mm	4/102	4/102	14/114	5/110	15/110	24/140	24/140
Stroke per minute	spm	54	54	60	60	60	50	50
Die hole diameter	mm	50	50	50	65	65	65	65
Throat depth	mm	270	280	280	330	325	390	430
Ram adjustment	mm	90 (manual)	90 (manual)	90 (manual)	90 (manual)	95 (motorized)	100 (motorized)	100 (motorized)
Ram dimension	mm	490 x 325	490 x 325	490 x 325	630 x 400	630 x 400	950 x 600	950 x 600
Table dimension	mm	750 x 500	900 x 540	900 x 540	1000 x 640	1100 x 700	1200 x 740	1250 x 850
Table hole diameter	mm	170	180	180	210	210	220	240
Table height from the ground	mm	765	750	790	780	810	820	825
Estimated press weight (~)	kg	4100	5400	5600	8200	9950	14900	16800
Estimated Press height (~)	mm	2750	2750	2800	3000	3200	3435	3550
Estimated Press depth (~)	mm	1800	2010	1870	2200	2400	2350	2400
Estimated Press width (~)	mm	1150	1390	1320	1372	1430	1700	1707
Motor power	kW	7,5	7,5	7,5	11	15	15	18,5
Stroke adjustment system	-	Manuel	Manuel	Manuel	Manuel	Semi-Automatic	Semi-Automatic	Semi-Automatic
Overload safety system	-	Mechanical	Mechanical	Mechanical	Mechanical	Hydraulic	Hydraulic	Hydraulic
Centralized lubrication system	-	Automatic Grease	Automatic Grease	Automatic Grease	Automatic Grease	Re-cycled automatic liquid	Re-cycled automatic liquid	Re-cycled automatic liquid
Clutch brake system	-	Pneumatic	Pneumatic	Pneumatic	Pneumatic	Pneumatic	Pneumatic	Pneumatic
Safety guard system	-	Photo-cell	Photo-cell	Photo-cell	Photo-cell	Photo-cell	Photo-cell	Photo-cell
Vibration pads	-	Standard	Standard	Standard	Standard	Standard	Standard	Standard
Speed control unit	-	Optional	Optional	Optional	Optional	Optional	Optional	Optional
Additional plate	-	Optional	Optional	Optional	Optional	Optional	Optional	Optional

We reserve the rights to make changes in design and drawing. The accessories of the machines shown on the catalogue may vary depending on the type of requested machine.



## Back Sided D Frame Lamination Press (8 Guide Ram)

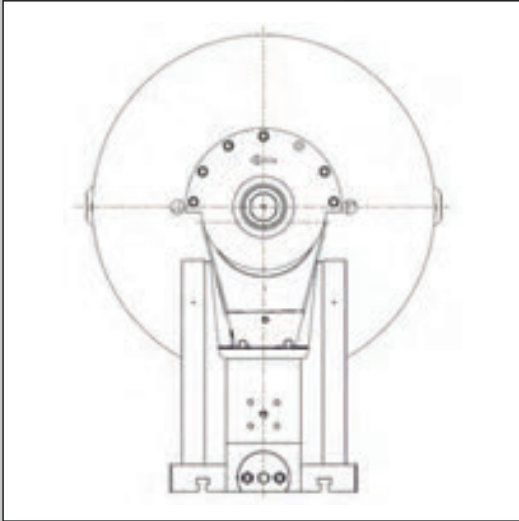

- Pneumatic clutch brake system
- Rigid body and ram
- 8 guide ram
- Spheroidal casting parts
- Hydraulic overload safety system
- Automatic ram adjustment according to customer requests
- Ergonomic design
- Compliance with 2006-42 Machinery Directives



# Technical Specifications

Properties	Unit	CDCS 601 P81/L	CDCS 801 P81/L	CDCS 1001 P81/L
Capacity	tons	60	80	100
Rated tonnage height	mm	2	2	4
Max closed die set height	mm	365	350	350
Stroke distance	mm	35	35	35
Press speed	spm	100-270	100-270	100-270
Die hole diameter	mm	45	45	50
Throat depth	mm	270	255	305
Ram adjustment	mm	90 (manual)	90 (manual)	95 (manual)
Ram dimension	mm	490 x 325	490 x 325	490 x 325
Table dimension	mm	750 x 500	860 x 540	860 x 540
Table hole diameter	mm	180	190	190
Table height from the ground	mm	770	810	800
Estimated press weight (~)	kg	4700	5400	6000
Estimated press height (~)	mm	2270	2370	2416
Estimated press depth (~)	mm	1920	2070	2070
Estimated press width (~)	mm	1100	1100	1210
Motor power	kW	7,5	11	15
Stroke adjustment system	-	Fixed	Fixed	Fixed
Overload safety system	-	Hydraulic	Hydraulic	Hydraulic
Centralized lubrication system	-	Re-cycled automatic liquid	Re-cycled automatic liquid	Re-cycled automatic liquid
Clutch brake system	-	Pneumatic	Pneumatic	Pneumatic
Die area safety system	-	Mechanical	Mechanical	Mechanical
Vibration pads	-	Standard	Standard	Standard
Speed control unit	-	Standard	Standard	Standard
Additional plate	-	Optional	Optional	Optional

## C Frame Hydraulic Press

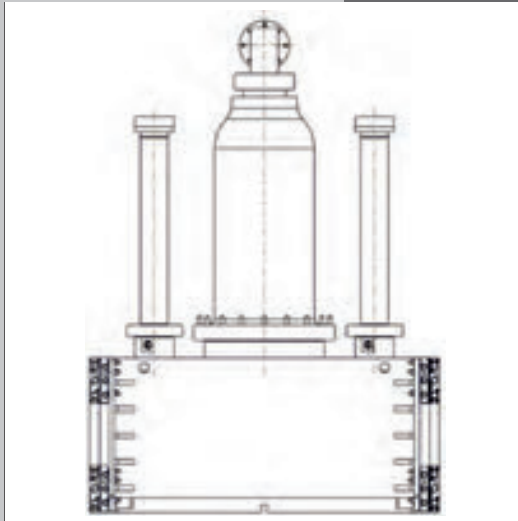

- Rigid body and ram
- Cushion unit
- User friendly ram adjustment
- Main cylinder and cushion unit pressure adjustment
- Certified hydraulic power unit
- Ergonomic design
- Compliance with 2006-42 Machinery Directives



# Technical Specifications

Properties	Unit	CDHC 630-400-250	CDHC 1000-400-400	CDHC 1600-400-630	CDHC 2000-400-630
Capacity	tons	63	100	160	200
Cushion capacity	tons	25	40	63	63
Stroke distance	mm	400	400	400	400
Cushion stroke distance	mm	150	150	150	150
Table dimension	mm	750x615	850x640	1000x740	1090x855
Ram dimension	mm	750x570	850x630	1000x680	1100x760
Max. distance between table and ram	mm	630	685	765	785
Working speed	mm/s	10-25	10-20	10-20	16
Rapid approach speed	mm/s	300	250	250	200
Estimated press weight (~)	kg	4900	7700	10500	14000
Estimated press height (~)	mm	3170	3565	3900	3910
Estimated press depth (~)	mm	1710	2030	2400	2510
Estimated press width (~)	mm	1150	1150	1525	1525
Motor power	kW	7,5	11	22	30
Centralized lubrication system	-	Automatic grease	Automatic grease	Automatic grease	Automatic grease
Die area safety system	-	Photo-cell	Photo-cell	Photo-cell	Photo-cell
Additional plate	-	Optional	Optional	Optional	Optional

## Single Connecting Rod H Frame Eccentric Press

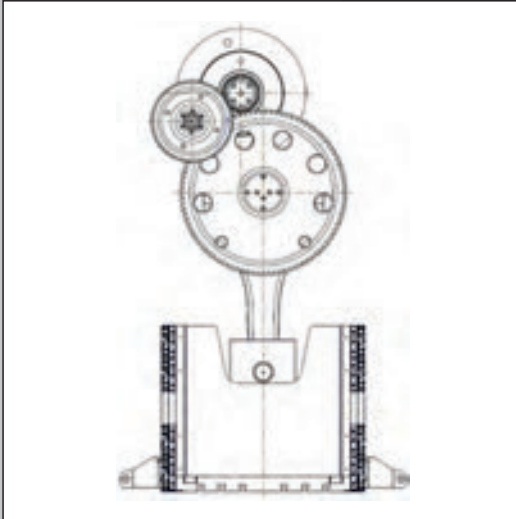

- Rigid body and ram
- 8 guide ram
- Helical, high quality gear system
- Spheroidal casting parts
- Hydraulic overload safety system
- Quick die changing system according to customer requests
- PLC Control and Touch Screen
- Cushion system according to customer requests
- Automatic stroke adjustment according to customer requests
- Progressive die applications
- Transfer die applications
- Lubrication control via special sensors
- Slide adjustment with encoder
- Ergonomic design
- Compliance with 2006-42 Machinery Directives





# Technical Specifications

Properties	Unit	CDCH 600 P	CDCH 800 P	CDCH 1100 P	CDCH 2500 P	CDCH 3000 P
Capacity	tons	60	80	110	250	300
Rated tonnage height	mm	5	4,5	4,5	3	6
Max. closed die set height	mm	520	480	480	550	650
Stroke distance	mm	120	70	70	20-160	180
Press speed	spm	50-70	50-70	50-70	35-45	25-35
Ram adjustment	mm	50 (motorized)	100 (motorized)	100 (motorized)	150 (motorized)	140 (motorized)
Table dimension	mm	800x600	1000x800	1000x800	1400x1000	1500x1000
Number of connecting rod	piece	1	1	1	1	1
Table height from the ground	mm	610	800	770	930	820
Estimated press weight (~)	kg	7000	12250	12000	20000	34000
Estimated press height (~)	mm	4070	4400	4400	4980	6000
Estimated press depth (~)	mm	1320	2100	2380	2700	2300
Estimated press width (~)	mm	2750	2380	2700	2545	3800
Motor power	kW	11	11	15	18,5	30
Stroke adjustment system	-	Fixed	Fixed	Fixed	Automatic	Fixed
Overload safety system	-	Hydraulic	Hydraulic	Hydraulic	Hydraulic	Hydraulic
Centralized lubrication system	-	Re-cyled automatic liquid	Re-cyled automatic liquid	Re-cyled automatic liquid	Re-cyled automatic liquid	Re-cyled automatic liquid
Clutch brake system	-	Pneumatic	Pneumatic	Pneumatic	Pneumatic	Pneumatic
Die area safety system	-	Photo-cell	Photo-cell	Photo-cell	Photo-cell	Photo-cell
Vibration pads	-	Standard	Standard	Standard	Standard	Standard
Speed control unit	-	Standard	Standard	Standard	Standard	Standard
Additional plate	-	Optional	Optional	Optional	Optional	Optional

We reserve the rights to make changes in design and drawing. The accessories of the machines shown on the catalogue may vary depending on the type of requested machine.

# CDCH P2B Series

## Double Connecting Rod H Frame Eccentric Press

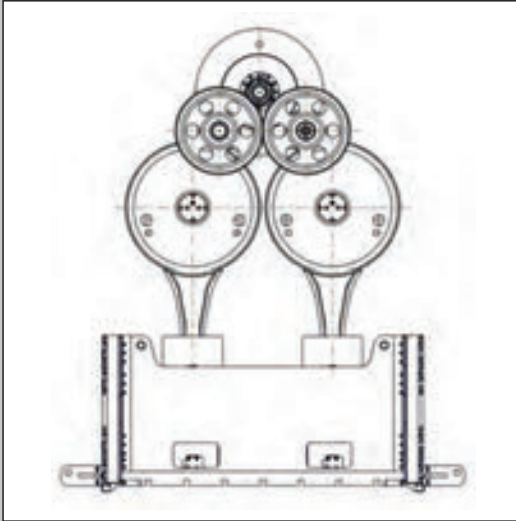

- Rigid body and ram
- 8 guide ram
- Helical, high quality gear system
- Spheroidal casting parts
- Hydraulic overload safety system
- Quick die changing system according to customer requests
- PLC Control and Touch Screen
- Cushion system according to customer requests
- Automatic stroke adjustment according to customer requests
- Progressive die applications
- Transfer die applications
- Lubrication control via special sensors
- Slide adjustment with encoder
- Ergonomic design
- Compliance with 2006-42 Machinery Directives



# Technical Specifications

Properties	Unit	CDCH 1200 P2B	CDCH 2000 P2B	CDCH 3000 P2B		CDCH 4000 P2B		CDCH 5000 P2B	CDCH 6300 P2B
Capacity	tons	120	200	300	300	400	400	500	630
Rated tonnage height	mm	5	4	6	8	7	10	5	7
Max. closed die set height	mm	500	600	500	640	660	650	700	850
Stroke distance	mm	120	180	180	160	200	300	350	350
Press speed	spm	50-80	35-70	26	25-40	20-30	30-40	20-30	20-35
<b>Ram adjustment</b>	mm	50 (motorized)	100 (motorized)	140 (motorized)	140 (motorized)	140 (motorized)	200 (motorized)	200 (motorized)	200 (motorized)
Table dimension	mm	1400x600	1600x1000	1800x1200	2000x1200	2200x1200	2500x1600	2800x1500	3000x1500
Number of connecting rod	piece	2	2	2	2	2	2	2	2
Table height from the ground	mm	840	1000	965	965	900	800	975	980
Estimated press weight (~)	kg	15000	20000	48000	48000	51000	67000	71000	85000
Estimated press height (~)	mm	4650	5144	5240	5260	5850	6150	6370	6780
Estimated press depth (~)	mm	1700	2100	2600	2550	2170	2400	2930	2880
Estimated press width (~)	mm	3530	3900	4400	4290	5100	5050	5280	5780
Motor power	kW	15	22	45	45	55	75	37	55
Stroke adjustment system	-	Fixed	Fixed	Fixed	Fixed	Fixed	Fixed	Fixed	Fixed
Overload safety system	-	Hydraulic	Hydraulic	Hydraulic	Hydraulic	Hydraulic	Hydraulic	Hydraulic	Hydraulic
Centralized lubrication system	-	Re-cyled automatic liquid	Re-cyled automatic liquid	Re-cyled automatic liquid	Re-cyled automatic liquid	Re-cyled automatic liquid	Re-cyled automatic liquid	Re-cyled automatic liquid	Re-cyled automatic liquid
Clutch brake system	-	Pneumatic	Pneumatic	Pneumatic	Pneumatic	Pneumatic	Pneumatic	Pneumatic	Pneumatic
Die area safety system	-	Photo-cell	Photo-cell	Photo-cell	Photo-cell	Photo-cell	Photo-cell	Photo-cell	Photo-cell
Vibration pads	-	Standard	Standard	Standard	Standard	Standard	Standard	Standard	Standard
Speed control unit	-	Standard	Standard	Optional	Standard	Standard	Standard	Standard	Standard
Additional plate	-	Optional	Optional	Optional	Optional	Optional	Optional	Optional	Optional

We reserve the rights to make changes in design and drawing. The accessories of the machines shown on the catalogue may vary depending on the type of requested machine.

## Modified Knuckle Joint Press

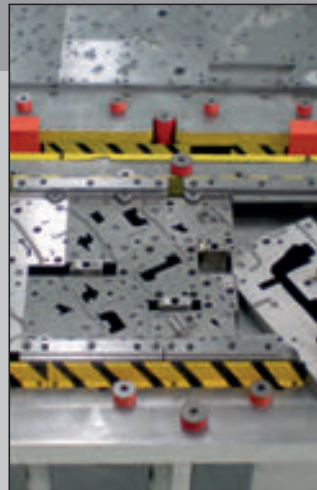
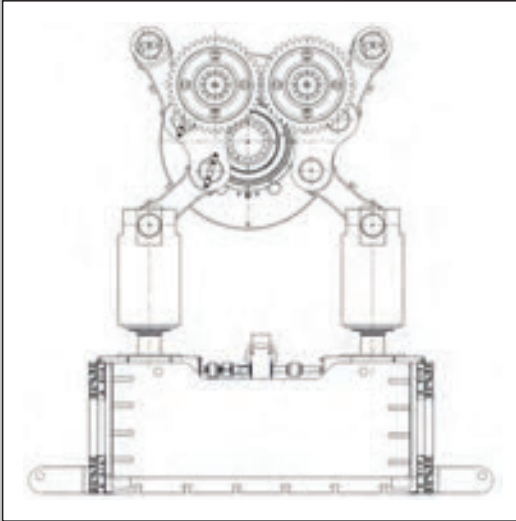

- Shock absorbing rigid body
- Compact, robust and extremely rigid structure
- Slowdown at bottom (BDC) dead center for better forming
- Longer die life
- Accelerated return speed
- Environment friendly with low impact noise and save energy
- High stroke rates even for complex formed parts
- Hydraulic overload safety system
- Ram adjustment system with encoder
- Special ram weight balancing system in accordance to press specifications
- Planet type clutch system
- Lubrication control via special sensors
- PLC Control and Touch Screen
- Die memory
- Ergonomic design
- Compliance with 2006-42 Machinery Directives



# Technical Specifications

Properties	Unit	CDCK 3150 PMU 2	CDCK 4000 PMU 2	CDCK 5000 PMU 2	CDCK 6300 PMU 2		CDCK 8000 PMU 2
Capacity	tons	315	400	500	630	630	800
Rated tonnage height	mm	6	8	8	5	10	10
Max. closed die set height	mm	600	850	860	550	700	700
Stroke distance	mm	160	250	250	80	250	250
Press speed	spm	30-50	30-50	30-50	60-80	30-50	30-50
Ram adjustment	mm	150 (motorized)	150 (motorized)	150 (motorized)	140 (motorized)	200 (motorized)	200 (motorized)
Table dimension	mm	1800x1200	1800x1200	1800x1200	1600x1200	2500x1400	2500x1400
Number of connecting rod	piece	2	2	2	2	2	2
Table height from the ground	mm	900	1020	1029	980	1040	1100
Estimated press weight (~)	kg	35000	40500	43500	58000	62000	110000
Estimated press height (~)	mm	5750	5850	5650	6150	7500	8000
Estimated press depth (~)	mm	2300	2400	2190	4500	5500	5700
Estimated press width (~)	mm	3300	3480	4210	2900	3100	3300
Motor power	kW	45	55	55	55	75	75
Stroke adjustment system	-	Fixed	Fixed	Fixed	Fixed	Fixed	Fixed
Overload safety system	-	Hydraulic	Hydraulic	Hydraulic	Hydraulic	Hydraulic	Hydraulic
Centralized lubrication system	-	Re-cyled automatic liquid	Re-cyled automatic liquid	Re-cyled automatic liquid	Re-cyled automatic liquid	Re-cyled automatic liquid	Re-cyled automatic liquid
Clutch brake system	-	Pneumatic	Pneumatic	Pneumatic	Pneumatic	Pneumatic	Pneumatic
Die area safety system	-	Photo-cell	Photo-cell	Photo-cell	Photo-cell	Photo-cell	Photo-cell
Vibration pads	-	Standard	Standard	Standard	Standard	Standard	Standard
Speed control unit	-	Standard	Standard	Standard	Standard	Standard	Standard
Additional plate	-	Optional	Optional	Optional	Optional	Optional	Optional

We reserve the rights to make changes in design and drawing. The accessories of the machines shown on the catalogue may vary depending on the type of requested machine.

## H Frame Hydraulic Press

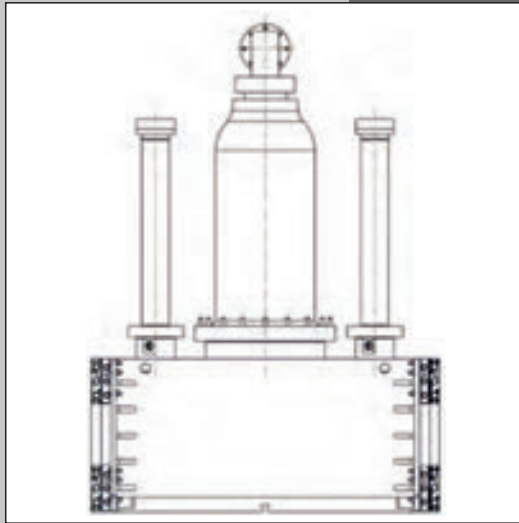

- Rigid body and ram
- User friendly ram adjustment
- Cushion unit
- Main cylinder and cushion unit pressure adjustment
- Certified hydraulic power unit
- Ergonomic design
- Compliance with 2006-42 Machinery Directives



# Technical Specifications

Properties	Unit	CDHH 2000-700-800	CDHH 2500-800-1600	CDHH 3000-800-1600	CDHH 4000-1000-00	CDHH 4000-700-800	CDHH 5000-140-00	CDHH 7500-600-1000	CDHH 8000-400-00	CDHH 12000-1050-3000	CDHH 15000-600-3000
Capacity	tons	200	250	300	400	400	500	750	800	1200	1500
Cushion capacity	tons	80	160	160	-	80	-	100	-	300	300
Stroke distance	mm	700	800	800	1000	700	140	600	400	1050	600
Cushion stroke distance	mm	300	355	440	-	350	-	360	-	300	225
Table dimension	mm	1600x1200	1200x1100	1400x1200	2000x1600	1600x1300	1400x700	1400x1400	1000x1000	1300x1300	1400x1400
Max. distance between table and ram	mm	950	1300	1300	1600	1140	340	1200	780	1200	1140
Table height from the ground	mm	900	1200	1180	1000	1200	900	1000	940	950	1000
Working speed	mm/s	10-20	35-62	35-95	10-35	10-35	10-20	25-45	10-20	10-20	25-45
Rapid approach speed	mm/s	200	540	200	200	200	200	480	200	200	480
Estimated press weight (~)	kg	25000	28600	32260	50000	42000	24000	82000	86000	93000	103000
Estimated press height (~)	mm	4650	5680	5600	6450	6049	4000	5900	4250	6490	6300
Estimated press depth	mm	2240	3000	2840	3933	2900	2950	4600	2340	4100	5400
Estimated press width (~)	mm	3240	4200	4000	4200	4340	3550	4520	2970	4300	4600
Motor power	kW	15	22	55	160	75	37	2x110	45	110	4x110
Centralized lubrication system	-	Automatic grease	Automatic grease	Automatic grease	Automatic grease	Automatic grease	Automatic grease	Automatic grease	Automatic grease	Automatic grease	Automatic grease
Die area safety system	-	Photo-cell	Photo-cell	Photo-cell	Photo-cell	Photo-cell	Photo-cell	Photo-cell	Photo-cell	Photo-cell	Photo-cell
Additional plate	-	Optional	Optional	Optional	Optional	Optional	Optional	Optional	Optional	Optional	Optional

We reserve the rights to make changes in design and drawing. The accessories of the machines shown on the catalogue may vary depending on the type of requested machine.



## Servo Press

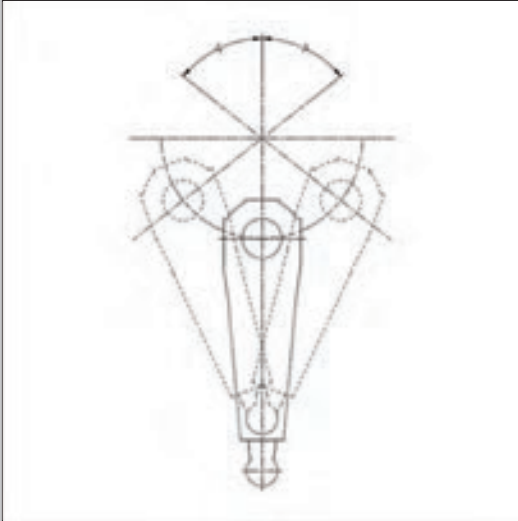

- Working Like Eccentric Press
- Multi Point Work
- Pendulum Work
- Multi Point Pendulum Work
- Part or Stroke Number Identification in 4 Different Mode
- Maximum 16 Programmable Cam System
- Die Adjustment Possibility by Hand Wheel
- Maximum 40 Kw Consumption with Advanced Energy Production
- Different Speed Adjustment Possibility Upto Maximum 10 Points in a Single Cycle Rate
- Forward-Backward Work in Symmetric Field adjusted at Bottom Death Center
- Speed Possibility upto Maximum 10 Points at Pendulum Movement

### OPTIONAL

- Die Protection System Against Over Load
- Tonnage Monitor System





# Technical Specifications

Properties	Unit	CDSH 1500 S
Capacity	(tons)	<b>150</b>
Rated tonnage height	(mm)	<b>1.4</b>
Max. closed die set height	(mm)	<b>500</b>
Stroke distance	(mm)	<b>100</b>
Press speed	(spm)	<b>100</b>
Ram adjustment	(mm)	<b>100</b>
Table dimension	(mm)	<b>1200x1000</b>
Table height from the ground	(mm)	<b>1040</b>
Estimated press weight (~)	(kg)	<b>~ 19200</b>
Estimated press height (~)	(mm)	<b>4550</b>
Estimated press depth (~)	(mm)	<b>3160</b>
Estimated press width (~)	(mm)	<b>2930</b>
Number of connecting rod	(piece)	<b>1</b>
Max. energy consumption	(kW)	<b>40</b>
Energy Supply	-	<b>3A ~ / N / PE 380 V 50 Hz</b>
Servo Motor Power	(kW)	<b>270</b>
Servo Motor Torque	(Nm)	<b>3300</b>
Gear ratio	-	<b>5,882</b>
Centralized lubrication system	-	<b>Re-cyled automatic liquid</b>
Die adjustment by hand wheel	-	<b>Standard</b>

We reserve the rights to make changes in design and drawing. The accessories of the machines shown on the catalogue may vary depending on the type of requested machine.





since 1952...



#### GROUP COMPANIES

- DİRİNLER MAKİNA SANAYİ (Eccentric and Hydraulic Press)
- DİRİNLER SANAYİ MAKİNALARI (CNC Machinery)
- DİRİNLER DÖKÜM SANAYİ (Grey and Nodular Cast Iron Parts)
- DİRİNLER GmbH

- LUPAMAT MAKİNA SANAYİ (Reciprocating and Screw Air Compressors)
- DİRİNLER TURİZM, LİMAN İŞLETMECİLİĞİ (Marina Management)
- TEKENTEK MAKİNA MODEL SAN.TİC.LTD.ŞTİ. (Pattern Production)



Made in Turkey

[www.dirinler.com.tr](http://www.dirinler.com.tr)



**dirinler**<sup>since 1952</sup><sup>®</sup>

Dirinler Makina Sanayi A.Ş.

A.O.S.B. 10036 Sokak No: 7 35620 Çiğli - İZMİR/TÜRKİYE

T: +90 232 376 72 00 (pbx) F: +90 232 376 72 06

[www.dirinler.com.tr](http://www.dirinler.com.tr)