



GREAT TOOLS. GREAT WORKMANSHIP.

Hole Saws • Hole Cutters • Magnetic Drill Machines

Professional
Trustworthiness
Customer Satisfaction



THE NO-NONSENSE BRAND

Since its establishment, Shajeng Hardware Co., Ltd. has been dedicated to the design and manufacturing of a comprehensive range of Tungsten Carbide Tipped / High Speed Steel hole saws and hole cutters.

Shajeng strives to be a manufacturing leader of high quality cutting tools. Qualified and well-experienced staff have been instrumental in upholding our reputation for world-class products, strict quality control policies and product development and innovation. Our strong research and development team has hugely contributed to Shajeng's future by developing its very own revolutionary cutting tools and equipment.

All shipments must go through an outgoing Quality Assurance inspection before shipment. All inspections are done on a sampling basis or according to the sampling plan we agree with our customers, and, in either case, by observing the C=0 sample plan rule.

Shajeng stocks a large inventory of cutting products for fast delivery to its customers worldwide with no lead-time necessary.

The Shajeng brand stands for Efficient Operation, Research and Creativity, Durability, Quality Control and Customer Satisfaction.

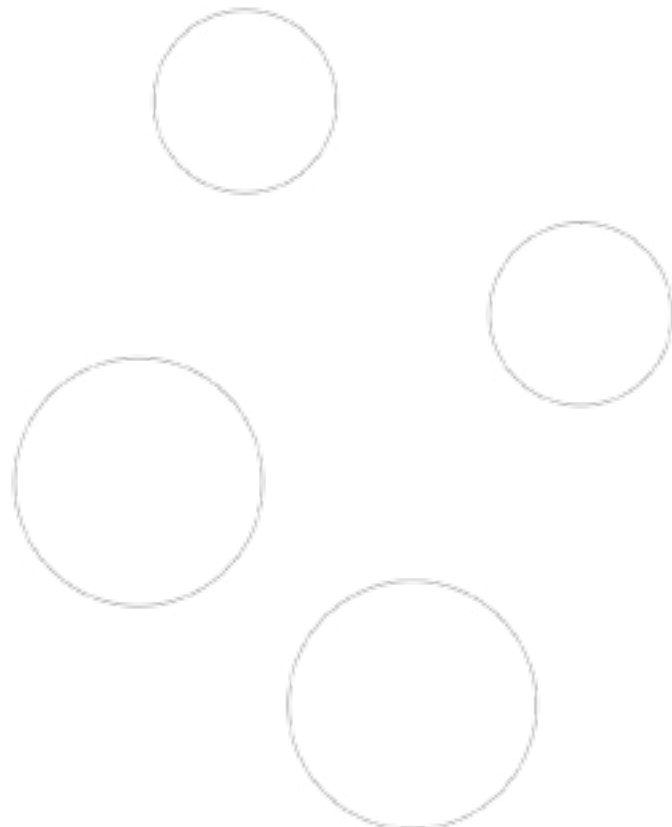

 Your Qualified Partner



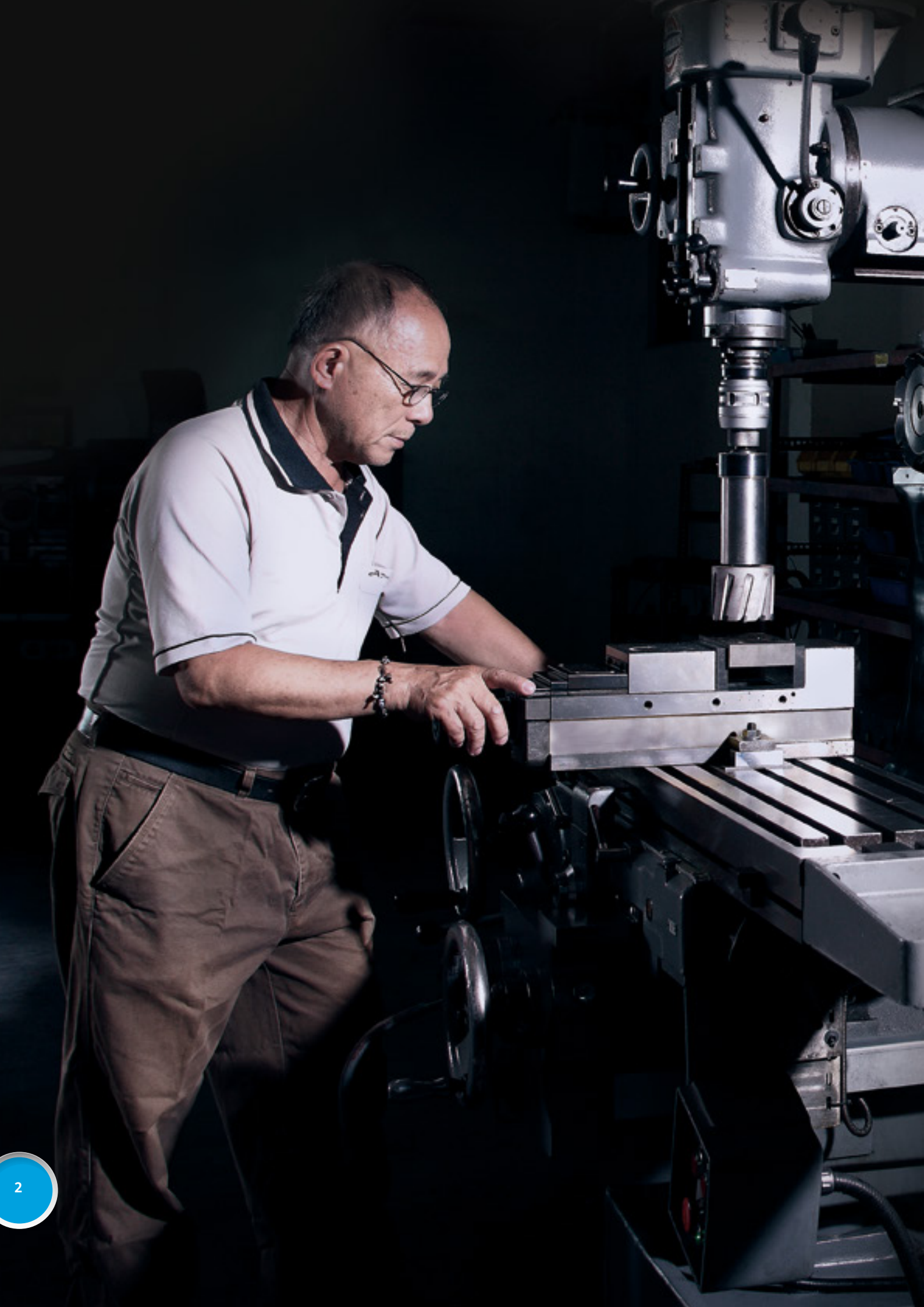

40 YEARS AND COUNTING

I was given a personal tour, from floor to floor. My host took me through the entire process, from raw materials to finished products, packaging and transport to warehousing. I was impressed. But that wasn't enough. They took the time to show me how it all worked and what their core competencies were; an efficient operation, a strong Research and Development team and a very strict quality control process.



100 FRIENDLY STAFF

I am a cutting tool distributor. I had been working with many manufacturers locally. Until one day, I received an intriguing letter of introduction from Shajeng Hardware from Taiwan. It had crossed my mind several times to expand my business and import Holesaws and drill bits directly from Asia. I took this opportunity to arrange my first visit to Taiwan and meet with Shajeng at their factory. I was greeted by an enthusiastic hardworking team; friendly, sincere and truly professional. And the best thing about it, they spoke my language.





3 Corporate Goals

Create continuous value to our owners, employees, customers and society.

Make constant innovation and offer complete customer service.

Stick to the original edge and create more advantages.





3Keego
SHAJENG

MG030
GRINDING MACHINE

80 MACHINE MODELS

I was pleasantly impressed by Shajeng for designing their unique machine to produce second to none hole saws. Shajeng's ability to transform ideas into reality by developing new innovative cutting tools and equipment was most convincing.





5

IMPORTANT STEPS

To ensure quality consistency, Shajeng puts each product through a variety of quality control tests. The product is tested at each step of the production process. They use a high-speed camera that displays drilling dynamics and curves. Imperfections are spotted immediately. A very impressive product health check!



101 WAYS

Shajeng's hole saws are sold worldwide to a variety of different industries. Each hole saw is designed with unique attributes that makes it suitable for a wide range of applications; construction steel, railways, shipping industry to name a few.

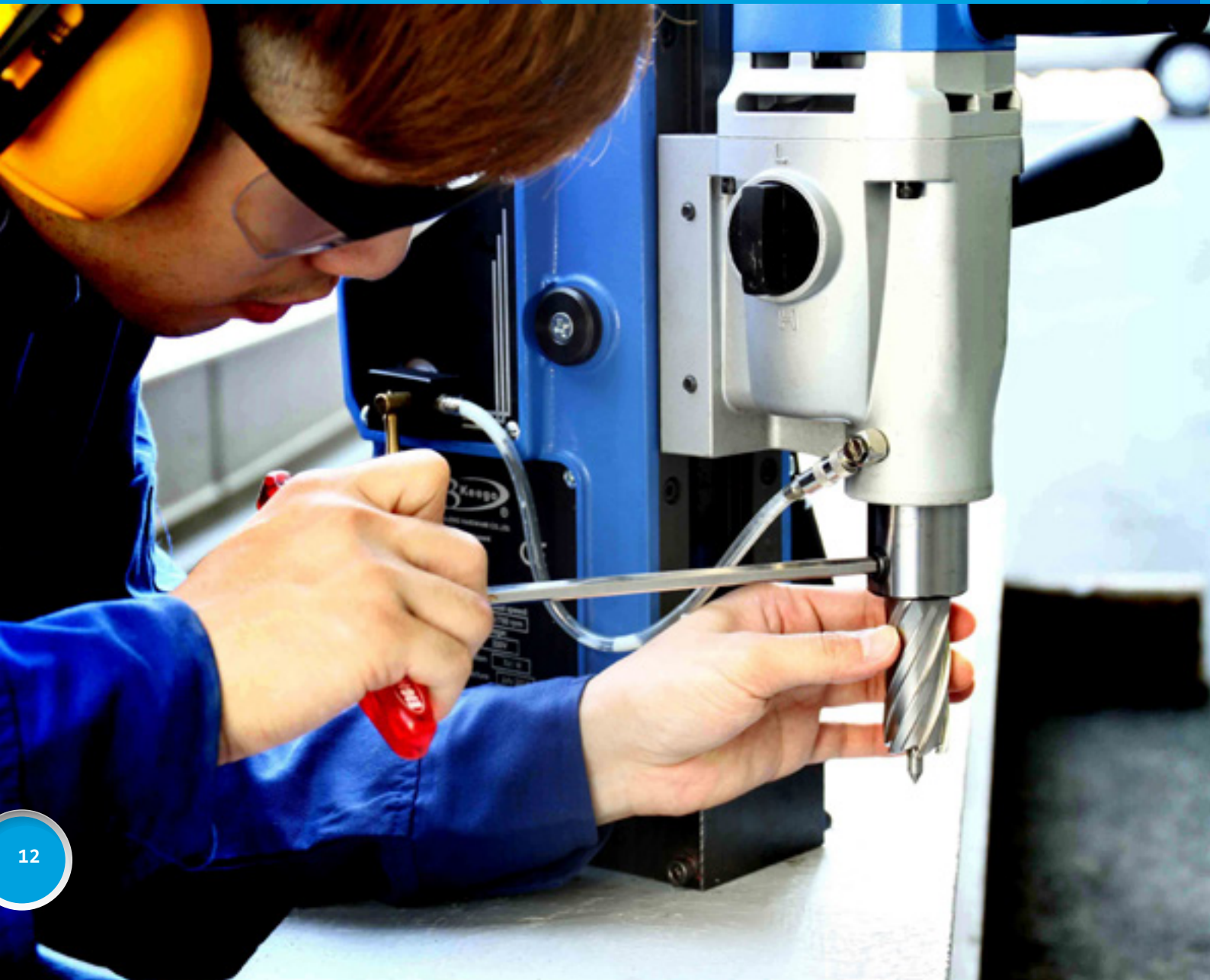



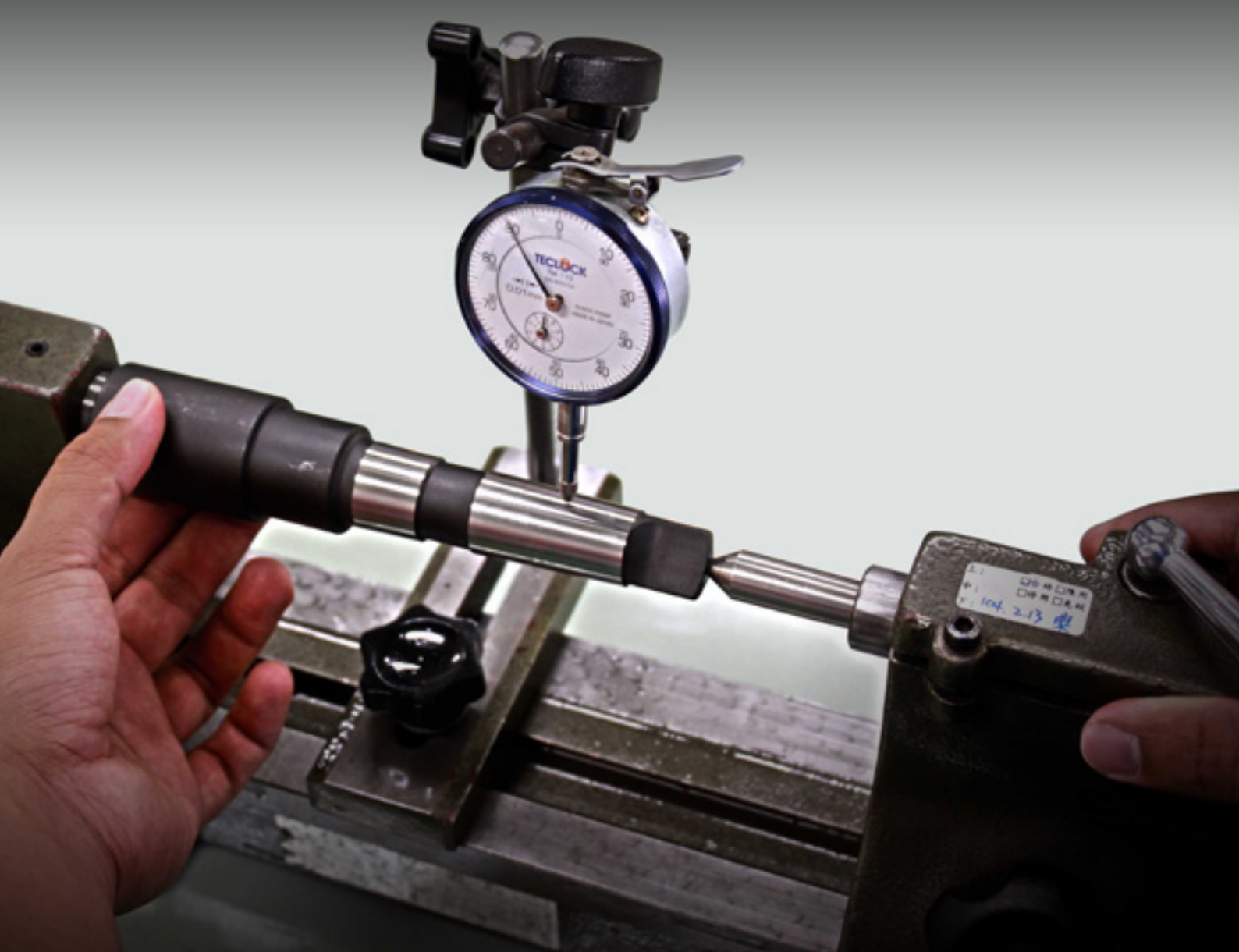

50 EXPORTING COUNTRIES

Today, I work closely with Shajeng because I know there is more to a great product than a good price. It takes a full team of experts, an efficient process and a strict quality control system to deliver a world-class product that adheres to International quality standards.





CONTENTS

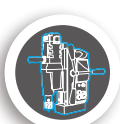

MAGNETIC DRILL MACHINE

SMD all features	18
SMD25	20
SMD30	22
SMD35	24
SMD50	26
SMD75	28



TCT HOLE SAW

TCT HOLE SAW all features	30
---------------------------------	----

HF	32
HL	34
HG	36
HP	38
HK	40
HM12	42
HM25	44
PL	46
HN	47

HR series

HRF	48
HRP	50
HRM	54

For wood

HW60	58
------------	----



HSS HOLE SAW

HSS HOLE SAW all features	60
SL	62
SF	63
SP	64
SG	65



CORE DRILL

CORE DRILL all features	66
HT	68
HD	70
HB	72



COUNTERSINK

COUNTERSINK all features	120
SCP	122
SCS	123



TCT HOLE CUTTER

TCT HOLE CUTTER all features	74
HC STANDARD SERIES	76
HC STANDARD TIN SERIES	80
HC SET	84
HC50S	85
HCD SERIES	86
HCL SERIES	88
HCR	90



BI-METAL HOLE SAW

BI-METAL all features	124
BI-METAL	125



CARBIDE BURR

CARBIDE BURR all features	126
CARBIDE BURR	128



HSS HOLE CUTTER

HSS HOLE CUTTER all features	92
SHC STANDARD SERIES	94
SHC STANDARD TIALN SERIES	97
SHC COBALT SERIES	100
SHC COBALT TIALN SERIES	103
SHC SET	106



ACCESSORIES

ADAPTERS	110
TOOL HOLDERS	111
TWIST DRILLS	112
EXTENSIONS	113
CHUCK ADAPTER	114
MAGNETIC CHIP COLLECTOR	115



STEP DRILL

STEP DRILL all features	116
SDT	118
SDR	119





MAGNETIC DRILL MACHINE

SHAJENG HARDWARE CO., LTD

MAGNETIC DRILL MACHINE BY 3Keego

All features in comparison.

SMD25

SMD30

SMD35



Model	SMD25	SMD30	SMD35
Voltage	110V AC , 50/60HZ	110V AC , 50/60HZ	110V AC , 50/60HZ
	220V AC , 50/60HZ	220V AC , 50/60HZ	220V AC , 50/60HZ
Power	1050 Watt	1050 Watt	1050 Watt
No Load RPM	550 RPM	750 RPM	550 / 750 RPM
Magnet Size	160mm × 80mm × 42mm	160mm × 80mm × 45mm	160mm × 80mm × 45mm
Magnet Holding Power	750kgf	750kgf	750kgf
Max. Hole Cutting Capacity	25mm dia × 30mm deep	30mm dia × 35mm deep	35mm dia × 50mm deep
Overall dimensions	Height : 210mm	Height : 315mm	Height : 350mm
	Width : 170mm	Width : 174mm	Width : 226mm
	Length : 290mm	Length : 342mm	Length : 390mm
Spindle bore	19.05mm(3/4")	19.05mm(3/4")	19.05mm(3/4")
Net Weight	9kgs	11kgs	15kgs
Stroke	30mm	140mm	140mm

SMD50

SMD75



SMD50	SMD75
110V AC , 50/60HZ	110V AC , 50/60HZ
220V AC , 50/60HZ	220V AC , 50/60HZ
1600 Watt	1600 Watt
250 / 550 RPM	120 / 180 / 320 / 440 RPM
182mm × 100mm × 45mm	182mm × 120mm × 50mm
1400kgf	1600kgf
50mm dia × 75mm deep	75mm dia × 100mm deep
Height : 390mm	Height : 429mm
Width : 226mm	Width : 226mm
Length : 403mm	Length : 415mm
19.05mm(3/4")	19.05mm(3/4")
18kgs	20kgs
170mm	180mm





SMD25

Power and Durability
Smarter Solutions For A Smarter Output.

MADE IN TAIWAN



FEATURES

- Light and Powerful
- High Performance
- Compact Model
- Longer Lifespan
- Easy Operation

POWER AND DURABILITY

Safe, reliable function and reduced noise.



HANDLE LEVER

ONE STAGE GEAR

For Powerful Requirements

VISUAL INDICATOR

For power and magnetic adhesion

SAFETY

Magnetic switch Motor switch

SPINDLE

19.05mm (3/4") Weldon shank

MAGNET BASE

160 x 80 x 42mm

ADVANTAGES



Adjustable lever can be mounted easily on right and left.



Provides good balance when carrying.

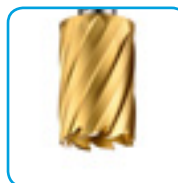

Cutter range: 12-25 mm dia, 30 mm deep



Applicable with:
H.S.S. Hole cutter
T.C.T. Hole cutter
(HC Series, HCR Series)



Combinations:
1 Coolant

DIMENSION

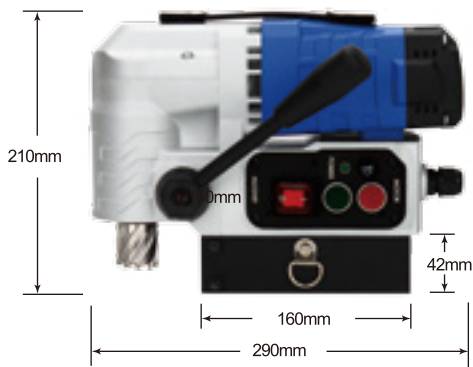

Reversible stroke handle.

SPECIFICATION

Voltage	110V AC , 50/60HZ
	220V AC , 50/60HZ
Power	1050 Watt
No Load RPM	550 RPM
Magnet Size	160mm × 80mm × 42mm
Magnet Holding Power	750kgf
Max. Hole Cutting Capacity	25mm dia × 30mm deep
Overall dimensions	Height : 210mm
	Width : 170mm
	Length : 290mm
Spindle bore	19.05mm(3/4")
Net Weight	9kgs

STANDARD EQUIPMENT

Description	Quantity
Magnetic drilling machine	1
Pilot pin	1
Shield	1
Wrench	1
Safety chain	1
Carrying case	1
Operating manual	1
Warranty certificate	1

With its low height, SMD25 able to drill in low height areas of steel structures.





SMD30

Power and Durability
Smarter Solutions For A Smarter Output.

FEATURES

- High Performance
- Compact Model
- Longer Lifespan
- Easy Operation

MADE IN TAIWAN



POWER AND DURABILITY

Safe, reliable function and reduced noise.

ONE STAGE GEAR

For Powerful Requirements

SPINDLE

19.05mm (3/4") Weldon shank

HANDLE LEVER

VISUAL INDICATOR

For power and magnetic adhesion

SAFETY

Magnetic switch Motor switch

MAGNET BASE

160 x 80 x 45mm

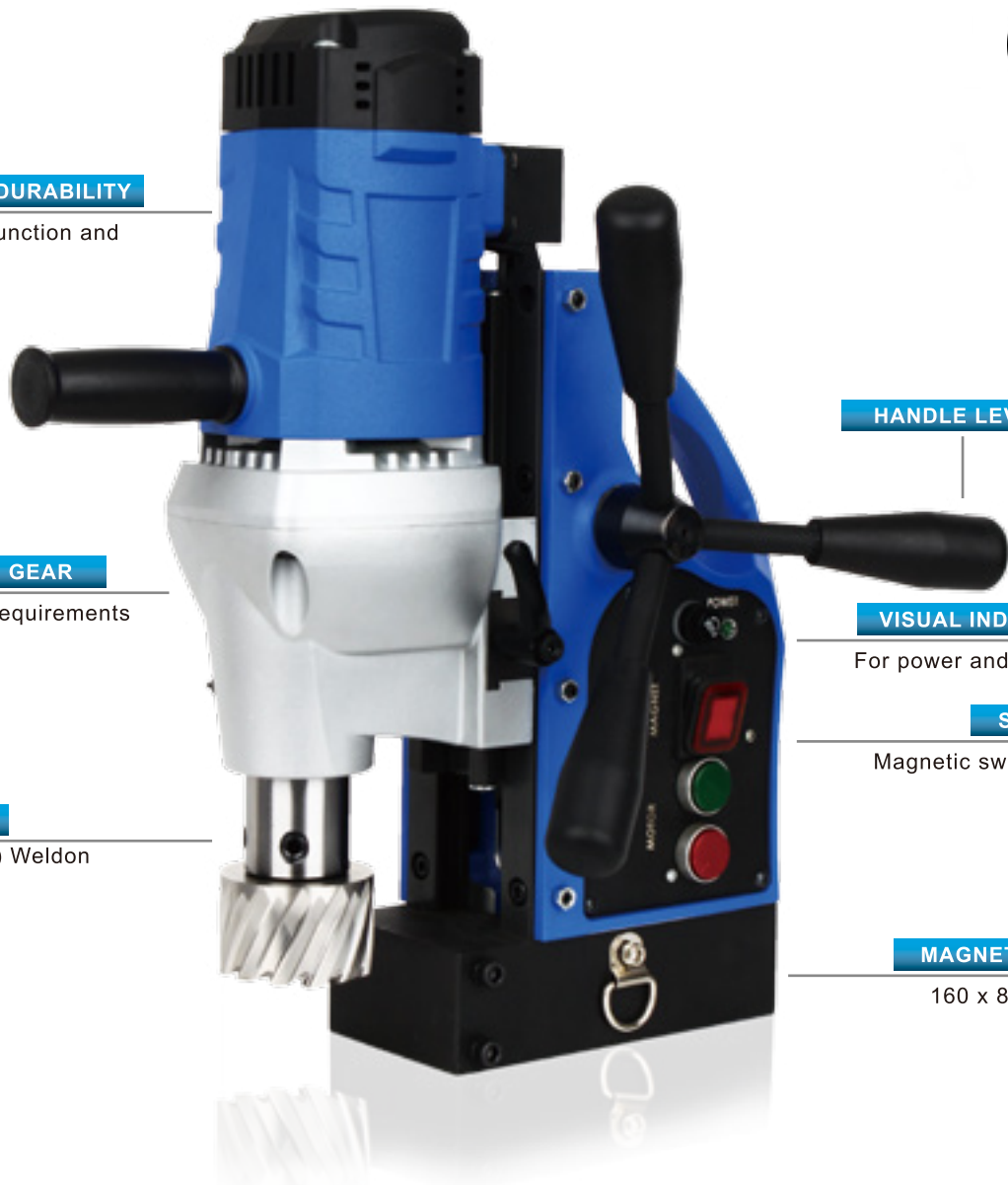

ADVANTAGES



Integrated cable routing



Twist drilling up to 12 mm



Cutter range: 12-30 mm dia, 35 mm deep



Applicable with:
H.S.S. Hole cutter
T.C.T. Hole cutter
(HC Series, HCR Series)



Slider adjustment



Combinations:
1 Coolant

DIMENSION



SPECIFICATION

Voltage	110V AC , 50/60HZ
	220V AC , 50/60HZ
Power	1050 Watt
No Load RPM	750 RPM
Magnet Size	160mm × 80mm × 45mm
Magnet Holding Power	750kgf
Max. Hole Cutting Capacity	30mm dia × 35mm deep
Overall dimensions	Height : 315mm
	Width : 174mm
	Length : 342mm
Spindle bore	19.05mm(3/4")
Net Weight	11kgs

STANDARD EQUIPMENT

Description	Quantity
Magnetic drilling machine	1
Geared drill chuck	1
Pilot pin	1
Shield	1
Wrench	1
Safety chain	1
Carrying case	1
Operating manual	1
Warranty certificate	1

DIMENSION

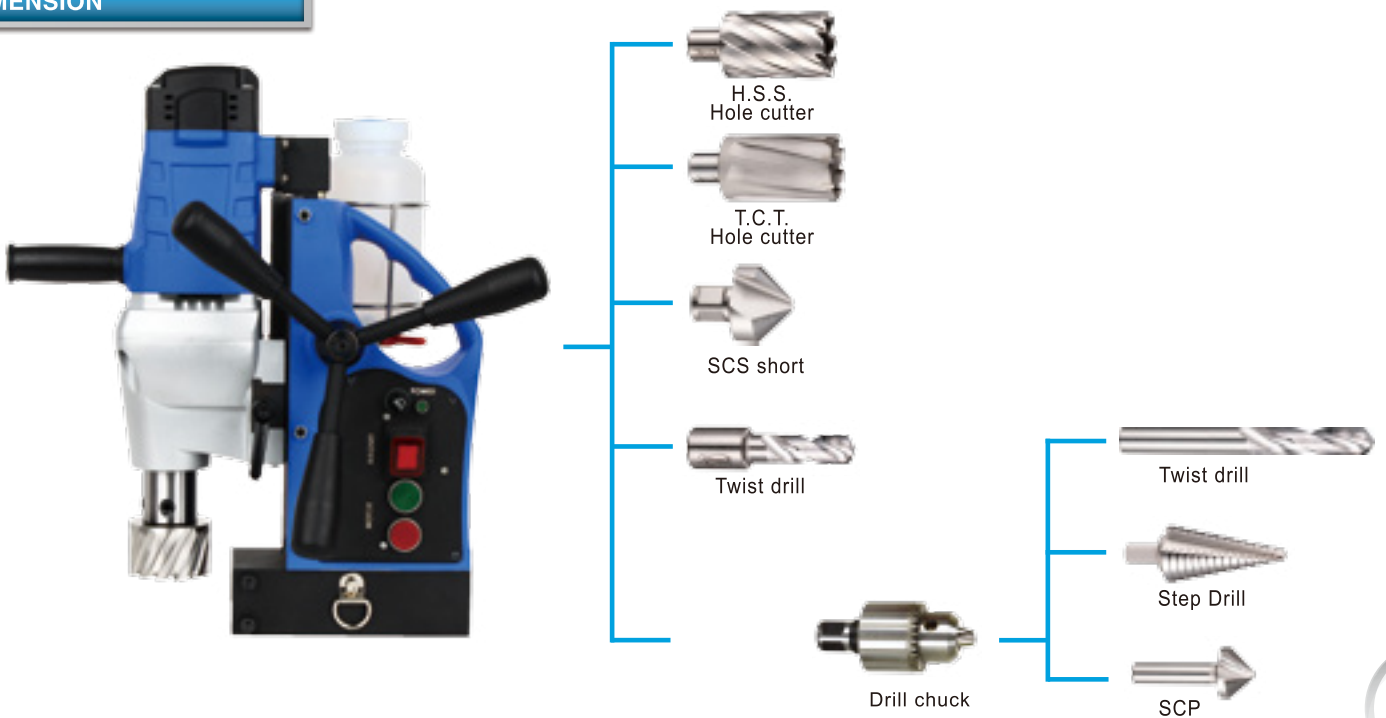



SMD35

Power and Durability
Smarter Solutions For A Smarter Output.

FEATURES

- High Performance
- Compact Model
- Longer Lifespan
- Easy Operation

MADE IN TAIWAN



POWER AND DURABILITY

Safe, reliable function and reduced noise.



BUILT-IN COOLANT

HANDLE LEVER

TWO STAGE GEAR

For Powerful Requirements

VISUAL INDICATOR

For power and magnetic adhesion

SPINDLE

19.05mm (3/4") Weldon shank

SAFETY

Magnetic switch Motor switch

MAGNET BASE

160 x 80 x 45mm

ADVANTAGES



Integrated cable routing



Integrated cutting oil reservoir



Two stage gear 550/750RPM



Twist drilling up to 12 mm



Cutter range: 12-35 mm dia, 50 mm deep



Slider adjustment



Combinations: 1 Coolant

DIMENSION

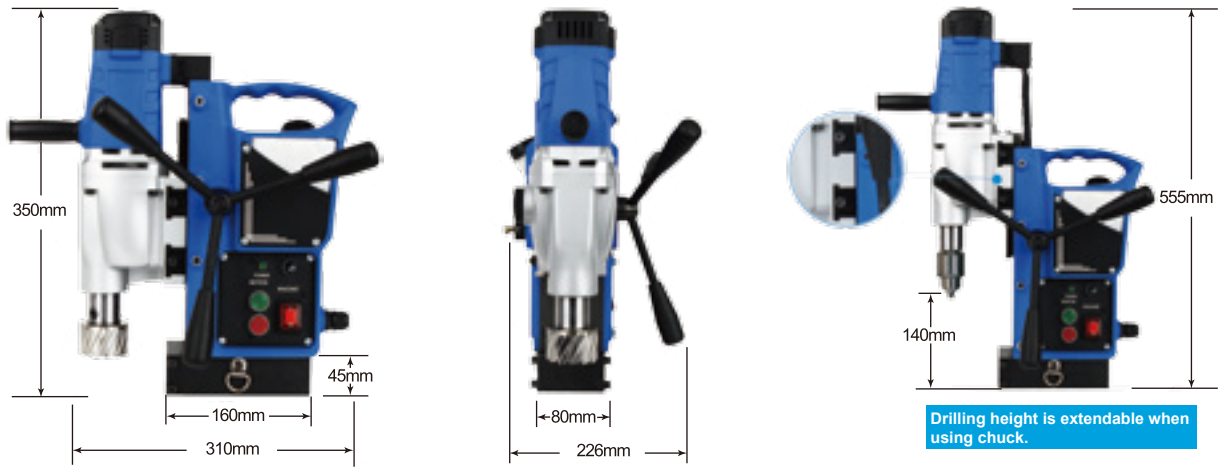

SPECIFICATION

Voltage	110V AC , 50/60HZ
	220V AC , 50/60HZ
Power	1050 Watt
No Load RPM	550 / 750 RPM
Magnet Size	160mm × 80mm × 45mm
Magnet Holding Power	750kgf
Max. Hole Cutting Capacity	35mm dia × 50mm deep
Overall dimensions	Height : 350mm
	Width : 226mm
	Length : 390mm
Spindle bore	19.05mm(3/4")
Net Weight	15kgs

STANDARD EQUIPMENT

Description	Quantity
Magnetic drilling machine	1
Geared drill chuck	1
Pilot pin	1
Shield	1
Wrench	1
Safety chain	1
Carrying case	1
Operating manual	1
Warranty certificate	1

DIMENSION

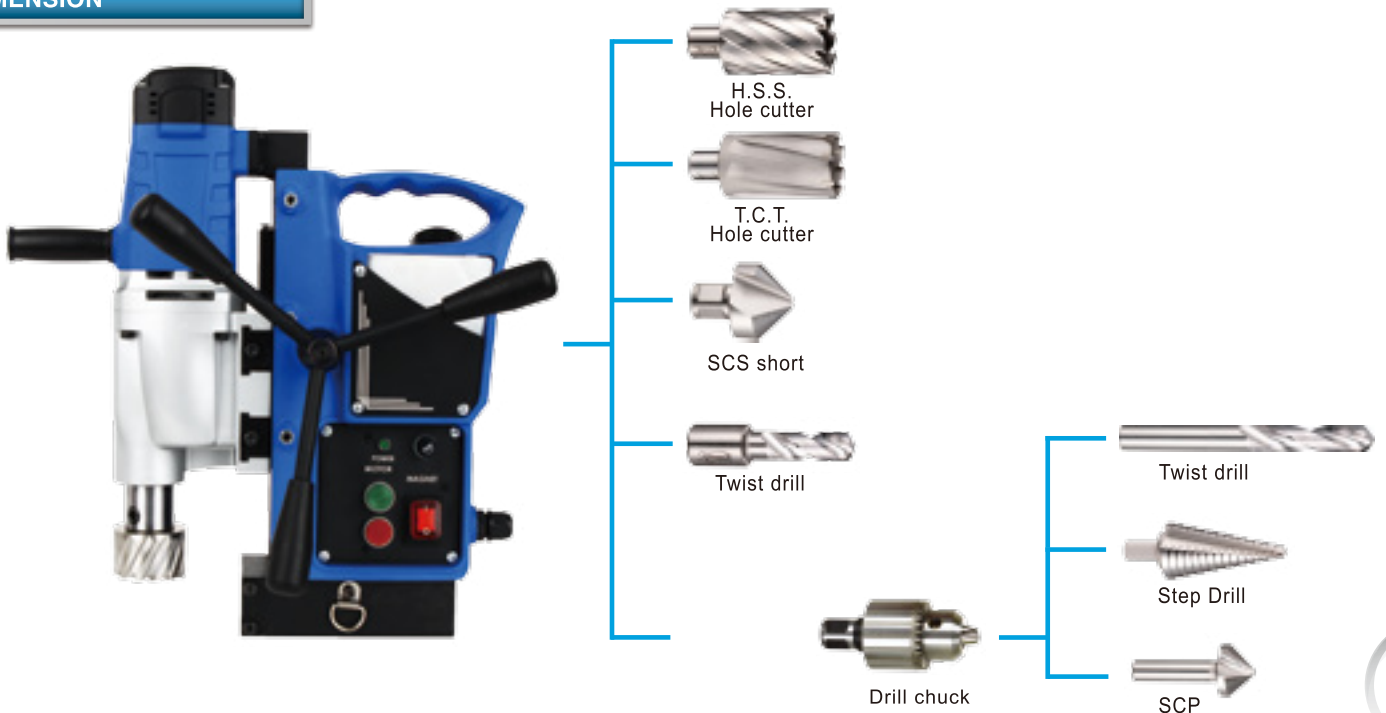



SMD50

Power and Durability
Smarter Solutions For A Smarter Output.

FEATURES

- High Performance
- Compact Model
- Longer Lifespan
- Easy Operation

MADE IN TAIWAN



POWER AND DURABILITY

Safe, reliable function and reduced noise.

TWO STAGE GEAR

For Powerful Requirements

SPINDLE

19.05mm (3/4") Weldon shank

BUILT-IN COOLANT

HANDLE LEVER

VISUAL INDICATOR

For power and magnetic adhesion

SAFETY

Magnetic switch Motor switch

MAGNET BASE

182 x 100 x 45mm



ADVANTAGES



Integrated cable routing



Integrated cutting oil reservoir



Two stage gear 250/550RPM



Twist drilling up to 12 mm



Cutter range: 12-50 mm dia, 75 mm deep

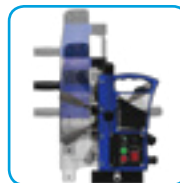

Slider adjustment



Combinations: 1 Coolant

DIMENSION

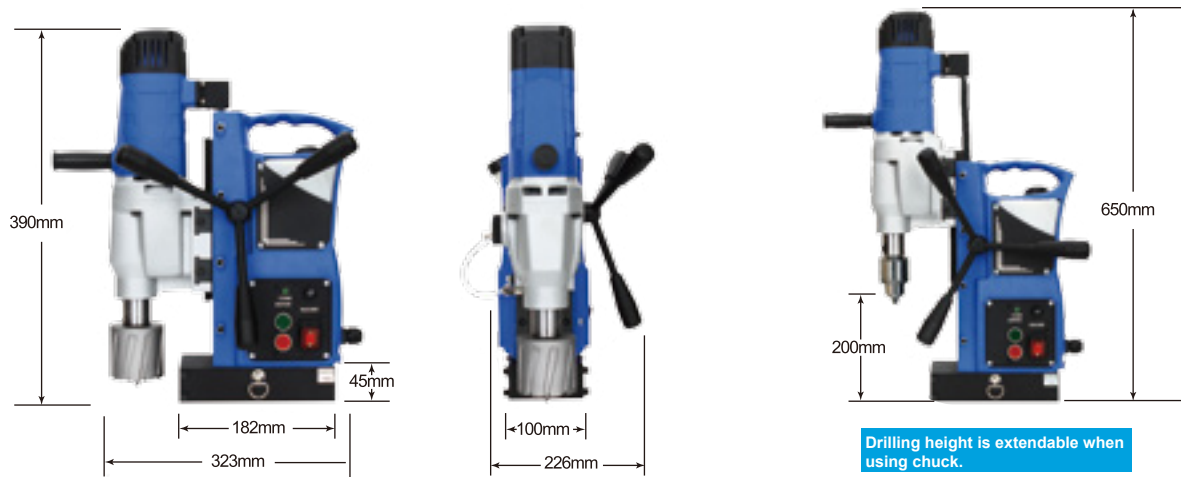

SPECIFICATION

Voltage	110V AC , 50/60HZ
	220V AC , 50/60HZ
Power	1600 Watt
No Load RPM	250 / 550 RPM
Magnet Size	182mm × 100mm × 45mm
Magnet Holding Power	1400kgf
Max. Hole Cutting Capacity	50mm dia × 75mm deep
Overall dimensions	Height : 390mm
	Width : 226mm
	Length : 403mm
Spindle bore	19.05mm(3/4")
Net Weight	18kgs

STANDARD EQUIPMENT

Description	Quantity
Magnetic drilling machine	1
Geared drill chuck	1
Pilot pin	1
Shield	1
Wrench	1
Safety chain	1
Carrying case	1
Operating manual	1
Warranty certificate	1

DIMENSION

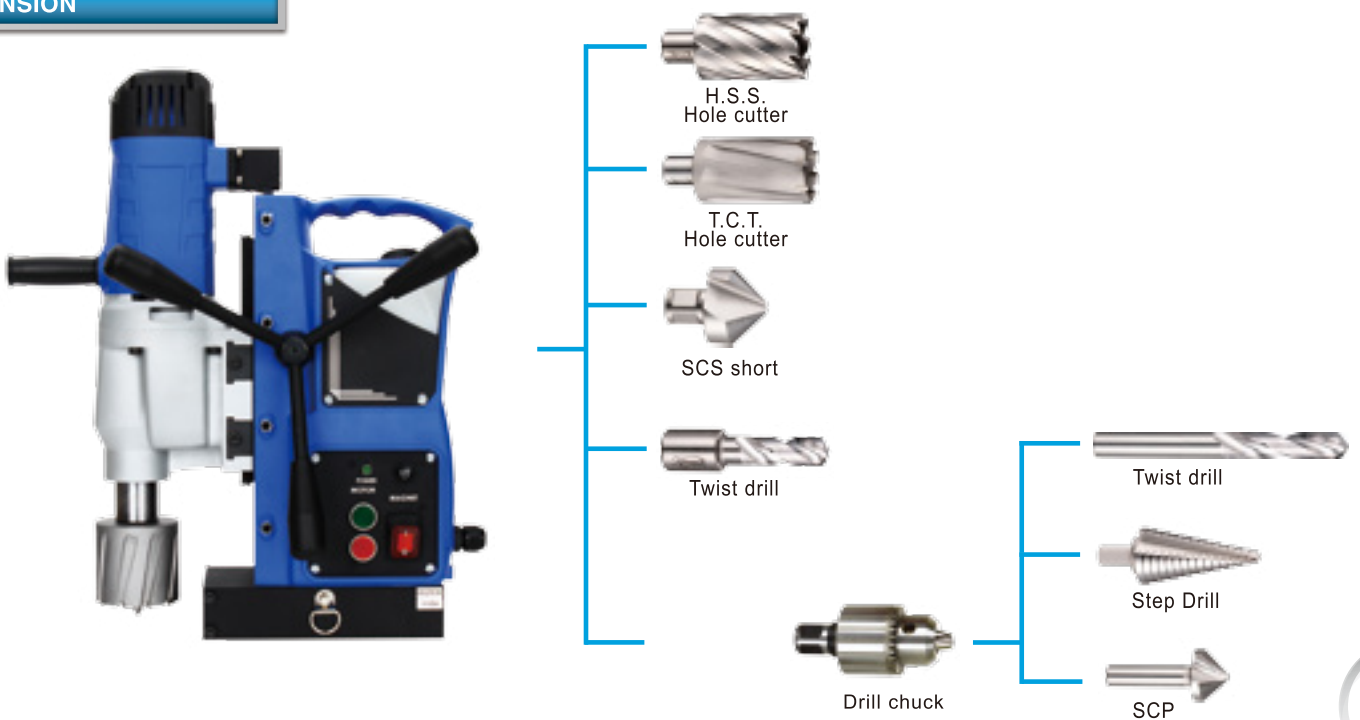



SMD75

Power and Durability
Smarter Solutions For A Smarter Output.

FEATURES

- High Performance
- Compact Model
- Longer Lifespan
- Easy Operation

MADE IN TAIWAN



POWER AND DURABILITY

Safe, reliable function and reduced noise.



FOUR STAGE GEAR

For Powerful Requirements

SPINDLE

19.05mm (3/4") Weldon shank

BUILT-IN COOLANT

HANDLE LEVER

VISUAL INDICATOR

For power and magnetic adhesion

SAFETY

Magnetic switch Motor switch

MAGNET BASE

182 x 120 x 50mm



ADVANTAGES



Integrated cable routing



Integrated cutting oil reservoir



Four stage gear
120/180/320/440RPM



Twist drilling up to 12 mm



Cutter range:
12-75 mm dia, 100 mm deep



Slider adjustment



Combinations:
1 Coolant

SMD75

SHAJENG HARDWARE CO., LTD

DIMENSION

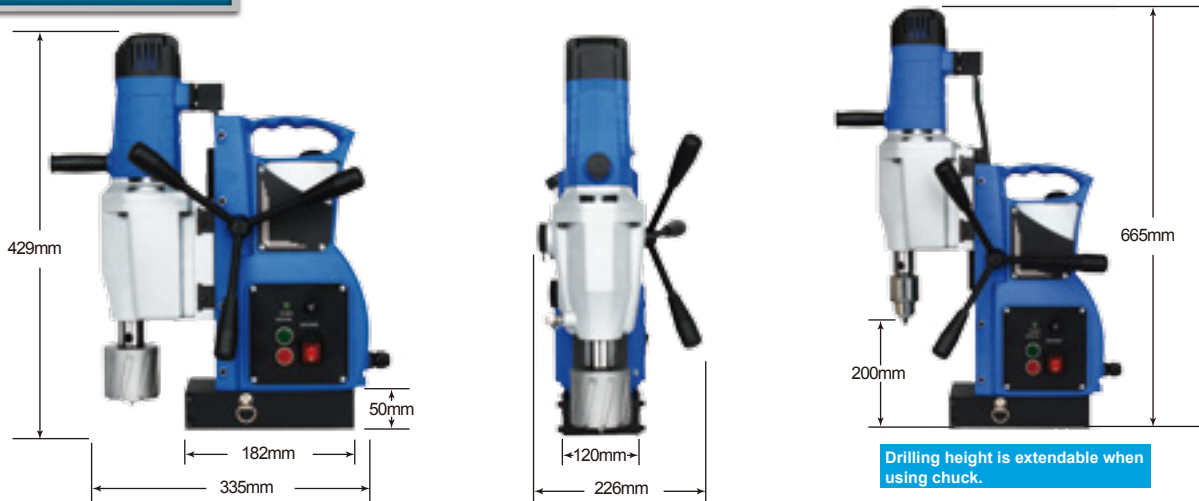

SPECIFICATION

Voltage	110V AC , 50/60HZ
	220V AC , 50/60HZ
Power	1600 Watt
No Load RPM	120 / 180 / 320 / 440 RPM
Magnet Size	182mm × 120mm × 50mm
Magnet Holding Power	1600kgf
Max. Hole Cutting Capacity	75mm dia × 100mm deep
Overall dimensions	Height : 429mm
	Width : 226mm
	Length : 415mm
Spindle bore	19.05mm (3/4")
Net Weight	20kgs

STANDARD EQUIPMENT

Description	Quantity
Magnetic drilling machine	1
Geared drill chuck	1
Pilot pin	1
Shield	1
Wrench	1
Safety chain	1
Carrying case	1
Operating manual	1
Warranty certificate	1

DIMENSION

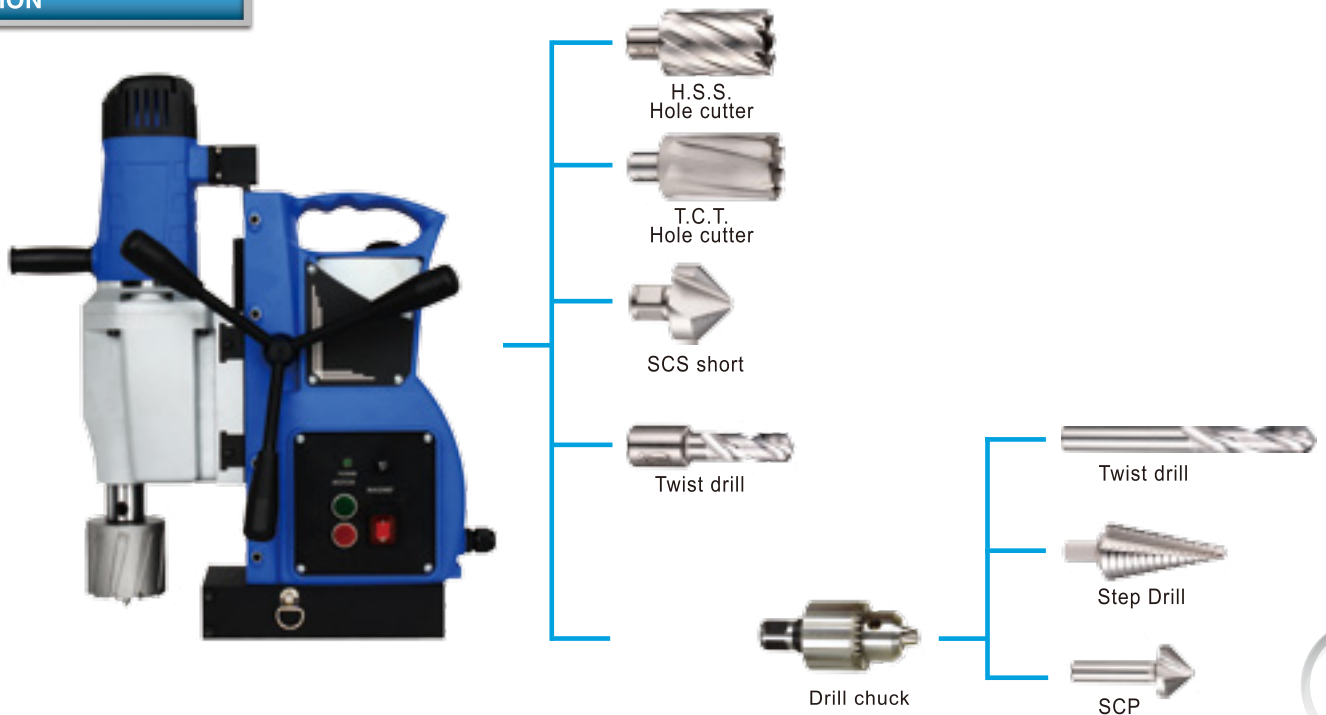

TCT HOLE SAW

All features in comparison.



	HF	HL	HG	HP	PL	HK	
Drilling depth	5mm	5mm	5mm	5mm	5mm	12mm	
Effective length	12mm	28mm	28mm	42mm	22mm	18mm	
Application Guide							
Metal Sheets SUS304	★★	★★	★★★	★★★	★★★	★★★	
Metal Sheets SS41	★★★	★★★	★★★	★★★	★★★	★★★	
Steel Pipes SUS304	★	★★	★★★	★★★	★	★★★	
Steel Pipes SS41	★	★★	★★★	★★★	★	★★★	
Cast Iron	★★★	★★★	★★★	★★★	★★★	★★★	
Aluminum	★	★	★	★	★	★	
Copper	★	★	★	★	★		
Bronze	★	★	★	★	★★	★	
I-Beam	★	★	★	★	★	★★★	
Fiber Glass	★★★	★★★	★★★	★★★	★★★	★★★	
L-Bar	★	★★	★★★	★★★	★★★	★★★	
Concrete							
Masonry							
PVC Pipes	★	★★★	★★★	★★★	★★★	★★★	
Railway							
Heat Treated Steel							
Square pipe	★★★	★★★	★★★	★★★	★★★	★★★	
Stacked Steel							
Wood							
Wood With Nails							



	HM12	HM25	HN	HRF	HRP	HRM	HW60
	12mm	25mm	25mm	5mm	5mm	25mm / 50mm	60mm
	28mm	35mm	35mm	12mm	50mm / 100mm	30mm / 55mm	70mm
Application Guide							
	★★	★★		★★	★★★	★★★	
	★★★	★★★		★★★	★★★	★★★	
	★	★		★	★★★	★	
	★	★		★	★★★	★	
	★★★	★★★		★★★	★★★	★★★	
	★	★	★★★	★	★	★	
	★	★	★★★	★	★	★	
	★	★	★★★	★	★	★	
	★★★	★★★		★★★	★★★	★★★	★
	★★	★		★	★★★	★	
	★★★	★★★		★	★★★	★★★	★
	★★★	★★		★★★	★★★	★★	
							★★★
							★★★

★★★ : Excellent, ★★ : Good, ★ : Fair



5 mm

HF TYPE

SHAJENG HARDWARE CO., LTD

HF TYPE

Complete with shank, center drill and ejector spring



EXTRA LIGHT-CUT
 Ø 14mm ~ Ø 100mm

FEATURES

- Material: Tungsten Carbide Micro Grade
- Drilling depth: 5mm thick
- Effective length: 12mm deep
- Low cutting pressure

APPLICATIONS

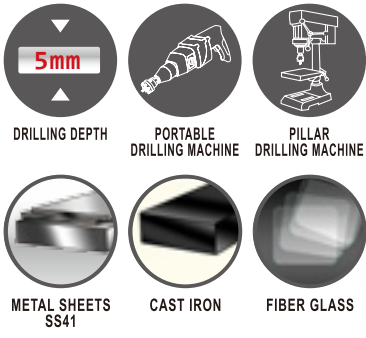

PROPERTIES



Center drill can lead the cutter to material as well as to prevent carbide damage.

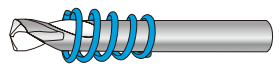

The slug is ejected by spring when cutting is finished.



With its extremely sharp Tungsten Carbide Tipped cutting edges, it can be run at higher feed rate and speed to create holes of exceptional precision and cleanliness.



Cutting Depth Limited to prevent over drill.

ADVANTAGES

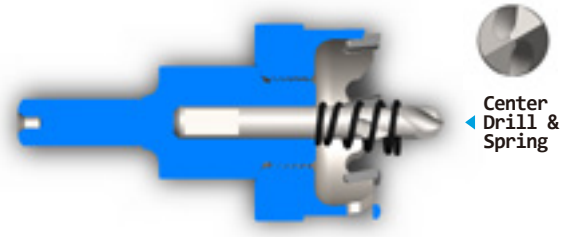
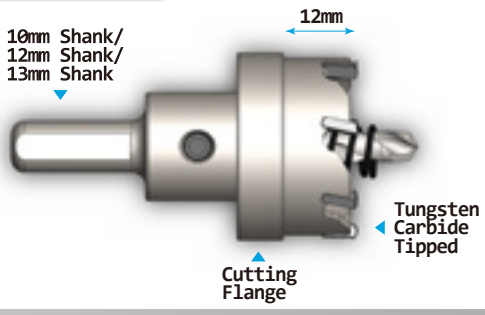

• HOLE SAW KIT
 3 Pcs. Mtl HS
 +1Pc. Center Drill+1Pc. Spring
 +1Pc. Hex Wrench



• HOLE SAW KIT
 6 Pcs. Mtl HS
 +2Pcs. Center Drill
 +1Pc. Spring, Hex Wrench

DIA.	ITEM NO.	DIA.	ITEM NO.
14mm	HF50140	45mm	HF50450
15mm	HF50150	46mm	HF50460
16mm	HF50160	47mm	HF50470
17mm	HF50170	48mm	HF50480
18mm	HF50180	49mm	HF50490
18.6mm	HF50186	50mm	HF50500
19mm	HF50190	51mm	HF50510
19.5mm	HF50195	52mm	HF50520
20mm	HF50200	53mm	HF50530
20.4mm	HF50204	54mm	HF50540
21mm	HF50210	55mm	HF50550
22mm	HF50220	56mm	HF50560
22.5mm	HF50225	57mm	HF50570
23mm	HF50230	58mm	HF50580
24mm	HF50240	59mm	HF50590
25mm	HF50250	60mm	HF50600
26mm	HF50260	61mm	HF50610
27mm	HF50270	62mm	HF50620
28mm	HF50280	63mm	HF50630
28.3mm	HF502830	64mm	HF50640
29mm	HF50290	65mm	HF50650
30mm	HF50300	66mm	HF50660
31mm	HF50310	67mm	HF50670
32mm	HF50320	68mm	HF50680
33mm	HF50330	69mm	HF50690
34mm	HF50340	70mm	HF50700
35mm	HF50350	72mm	HF50720
36mm	HF50360	73mm	HF50730
37mm	HF50370	75mm	HF50750
38mm	HF50380	76mm	HF50760
39mm	HF50390	77mm	HF50770
40mm	HF50400	80mm	HF50800
41mm	HF50410	85mm	HF50850
42mm	HF50420	90mm	HF50900
43mm	HF50430	95mm	HF50950
44mm	HF50440	100mm	HF51000

CENTER DRILL	PART NO.
--------------	----------

φ14mm~φ100mm: φ6mm×50L (from 9/16"~5-5/8")	M-CD60500
---	-----------

SPRING	PART NO.
--------	----------

φ14mm~φ100mm (from 9/16"~3-7/8")	M-SP6050HF
-------------------------------------	------------

CENTER DRILL + SPRING	PART NO.
-----------------------	----------

φ14mm~φ100mm (from 9/16"~3-7/8")	M-SP6050HFW
-------------------------------------	-------------

ACCESSORY ARBOR	PART NO.
-----------------	----------

φ25mm~φ60mm: 10mm shank (from 1"~2-3/8")	AB-TS05521D6
---	--------------

φ61mm~φ100mm: 12mm shank (from 2-7/16"~3-7/8")	AB-TS05524D6
---	--------------

φ4"~φ5-5/8": 13mm shank	AB-TS05531D8
-------------------------	--------------

DIA.	ITEM NO.
9/16"	HF501429
5/8"	HF501588
11/16"	HF501746
3/4"	HF501905
13/16"	HF502064
7/8"	HF502223
15/16"	HF502381
1"	HF502540
1-1/16"	HF502699
1-1/8"	HF502858
1-3/16"	HF503016
1-7/32"	HF503096
1-1/4"	HF503175
1-5/16"	HF503334
1-3/8"	HF503493
1-7/16"	HF503651
1-1/2"	HF503810
1-9/16"	HF503969
1-5/8"	HF504128
1-11/16"	HF504286
1-3/4"	HF504445
1-13/16"	HF504604
1-7/8"	HF504763
1-15/16"	HF504921
2"	HF505080
2-1/16"	HF505239
2-1/8"	HF505398
2-3/16"	HF505556
2-1/4"	HF505715
2-5/16"	HF505874
2-3/8"	HF506033
2-7/16"	HF506191
2-1/2"	HF506350
2-9/16"	HF506509
2-5/8"	HF506668
2-3/4"	HF506985
2-7/8"	HF507303
3"	HF507620
3-1/8"	HF507938
3-1/4"	HF508255
3-1/2"	HF508890
3-5/8"	HF509208
3-3/4"	HF509525
3-7/8"	HF509843
4"	HF510160
4-1/2"	HF511430
5-5/8"	HF514288



5 mm

HL TYPE

SHAJENG HARDWARE CO., LTD

HL TYPE

Complete with shank, center drill and ejector spring



LIGHT-CUT
 Ø 15mm ~ Ø 100mm

FEATURES

- Material: Tungsten Carbide Micro Grade
- Drilling depth: 5mm thick
- Effective length: 28mm deep

APPLICATIONS

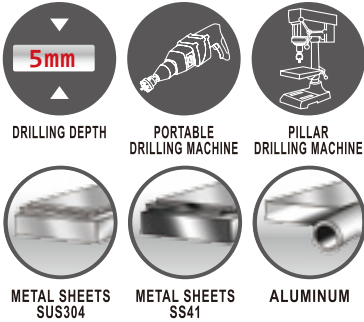

(See page 30 for more cutter's application)

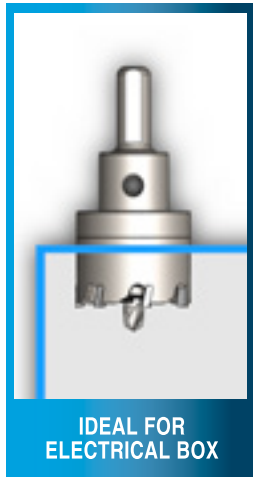

IDEAL FOR ELECTRICAL BOX



PROPERTIES



- Center drill can lead the cutter to material as well as to prevent carbide damage.



- The slug is ejected by spring when cutting is finished.

- With its extremely sharp Tungsten Carbide Tipped cutting edges, it can be run at higher feed rate and speed to create holes of exceptional precision and cleanliness.

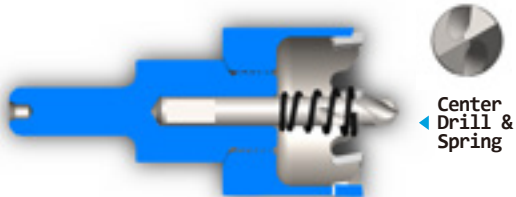
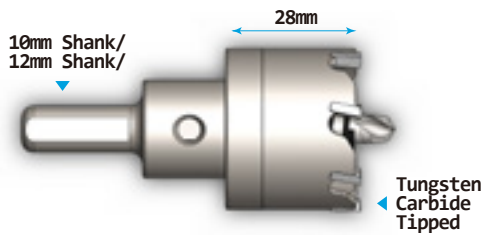

Different packaging to meet different requirement.

DIA.	ITEM NO.	DIA.	ITEM NO.	DIA.	ITEM NO.
15mm	HL20150	35mm	HL20350	60mm	HL20600
16mm	HL20160	36mm	HL20360	61mm	HL20610
16.5mm	HL20165	37mm	HL20370	62mm	HL20620
17mm	HL20170	38mm	HL20380	63mm	HL20630
18mm	HL20180	39mm	HL20390	64mm	HL20640
19mm	HL20190	40mm	HL20400	65mm	HL20650
19.5mm	HL20195	41mm	HL20410	66mm	HL20660
20mm	HL20200	42mm	HL20420	67mm	HL20670
20.5mm	HL20205	43mm	HL20430	68mm	HL20680
21mm	HL20210	44mm	HL20440	69mm	HL20690
22mm	HL20220	45mm	HL20450	70mm	HL20700
22.5mm	HL20225	46mm	HL20460	72mm	HL20720
23mm	HL20230	47mm	HL20470	73mm	HL20730
24mm	HL20240	48mm	HL20480	75mm	HL20750
25mm	HL20250	49mm	HL20490	76mm	HL20760
25.5mm	HL20255	50mm	HL20500	79mm	HL20790
26mm	HL20260	51mm	HL20510	80mm	HL20800
27mm	HL20270	52mm	HL20520	83mm	HL20830
28mm	HL20280	53mm	HL20530	85mm	HL20850
29mm	HL20290	54mm	HL20540	89mm	HL20890
30mm	HL20300	55mm	HL20550	90mm	HL20900
31mm	HL20310	56mm	HL20560	95mm	HL20950
32mm	HL20320	57mm	HL20570	96mm	HL20960
33mm	HL20330	58mm	HL20580	100mm	HL21000
34mm	HL20340	59mm	HL20590		

ACCESSORY ARBOR	PART NO.	SPRING	PART NO.
φ25mm~φ60mm: 10mm shank	AB-TS05521D6	φ15mm~φ17mm	M-SP6060SS
φ61mm~φ100mm: 12mm shank	AB-TS05524D6	φ18mm~φ100mm	M-SP6060BB
CENTER DRILL	PART NO.	CENTER DRILL + SPRING	PART NO.
φ15mm~φ100mm: φ6mm×60L	M-CD60600	φ15mm~φ17mm	M-SP6060SSW
		φ18mm~φ100mm	M-SP6060BBW



TCT HOLE SAW / HL TYPE

5 mm

HG TYPE

SHAJENG HARDWARE CO., LTD

HG TYPE

Complete with shank, center drill and ejector spring



HEAVY-DUTY
 ϕ 13mm ~ ϕ 200mm

FEATURES

- Material: Tungsten Carbide Micro Grade
- Drilling depth: 5mm thick
- Effective length: 28mm deep

APPLICATIONS

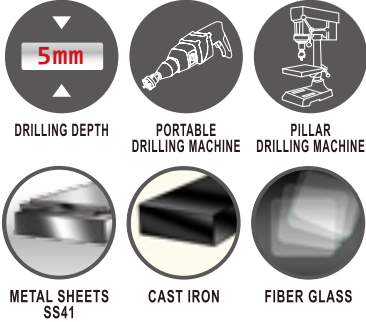

(See page 30 for more cutter's application)

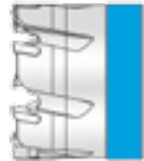

PROPERTIES



- Center drill can lead the cutter to material as well as to prevent carbide damage.

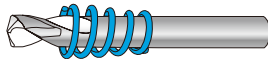

- The slug is ejected by spring when cutting is finished.



- With its extremely sharp Tungsten Carbide Tipped cutting edges, it can be run at higher feed rate and speed to create holes of exceptional precision and cleanliness.

- Cutting Depth Limited to prevent over drill.

ADVANTAGES

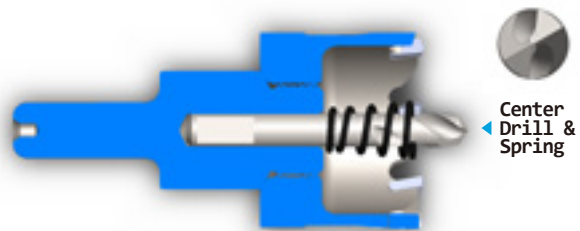
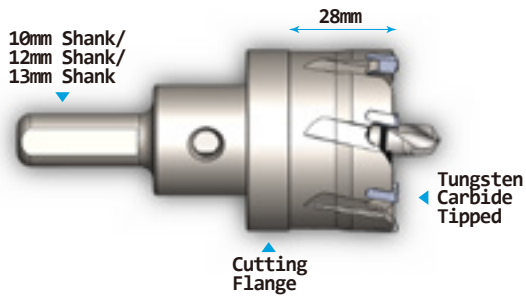

DIA.	ITEM NO.	DIA.	ITEM NO.	DIA.	ITEM NO.	DIA.	ITEM NO.
9/16"	HG601429	13mm	HG60130	47mm	HG60470	84mm	HG60840
5/8"	HG601588	14mm	HG60140	48mm	HG60480	85mm	HG60850
11/16"	HG601746	15mm	HG60150	49mm	HG60490	86mm	HG60860
3/4"	HG601905	16mm	HG60160	50mm	HG60500	87mm	HG60870
13/16"	HG602064	17mm	HG60170	51mm	HG60510	89mm	HG60890
7/8"	HG602223	18mm	HG60180	52mm	HG60520	90mm	HG60900
15/16"	HG602381	19mm	HG60190	53mm	HG60530	91mm	HG60910
1"	HG602540	19.5mm	HG60195	54mm	HG60540	93mm	HG60930
1-1/16"	HG602699	20mm	HG60200	55mm	HG60550	95mm	HG60950
1-1/8"	HG602858	21mm	HG60210	56mm	HG60560	98mm	HG60980
1-3/16"	HG603016	22mm	HG60220	57mm	HG60570	100mm	HG61000
1-1/4"	HG603175	23mm	HG60230	58mm	HG60580	102mm	HG61020
1-5/16"	HG603334	24mm	HG60240	59mm	HG60590	105mm	HG61050
1-3/8"	HG603493	25mm	HG60250	60mm	HG60600	110mm	HG61100
1-7/16"	HG603651	25.5mm	HG60255	61mm	HG60610	112mm	HG61120
1-1/2"	HG603810	26mm	HG60260	62mm	HG60620	115mm	HG61150
1-9/16"	HG603969	27mm	HG60270	63mm	HG60630	116mm	HG61160
1-5/8"	HG604128	28mm	HG60280	64mm	HG60640	120mm	HG61200
1-11/16"	HG604286	29mm	HG60290	65mm	HG60650	122mm	HG61220
1-3/4"	HG604445	30mm	HG60300	66mm	HG60660	125mm	HG61250
1-13/16"	HG604604	31mm	HG60310	67mm	HG60670	130mm	HG61300
1-7/8"	HG604763	32mm	HG60320	68mm	HG60680	132mm	HG61320
1-15/16"	HG604921	33mm	HG60330	69mm	HG60690	135mm	HG61350
2"	HG605080	34mm	HG60340	70mm	HG60700	140mm	HG61400
2-1/16"	HG605239	35mm	HG60350	71mm	HG60710	142mm	HG61420
2-1/8"	HG605398	36mm	HG60360	72mm	HG60720	145mm	HG61450
2-3/16"	HG605556	37mm	HG60370	73mm	HG60730	150mm	HG61500
2-1/4"	HG605715	38mm	HG60380	74mm	HG60740	155mm	HG61550
2-5/16"	HG605874	39mm	HG60390	75mm	HG60750	160mm	HG61600
2-3/8"	HG606033	40mm	HG60400	76mm	HG60760	165mm	HG61650
2-7/16"	HG606191	41mm	HG60410	77mm	HG60770	170mm	HG61700
2-1/2"	HG606350	42mm	HG60420	78mm	HG60780	180mm	HG61800
2-9/16"	HG606509	43mm	HG60430	79mm	HG60790	190mm	HG61900
2-5/8"	HG606668	44mm	HG60440	80mm	HG60800	200mm	HG62000
2-3/4"	HG606985	45mm	HG60450	81mm	HG60810		
2-7/8"	HG607303	46mm	HG60460	83mm	HG60830		
3"	HG607620						
3-1/8"	HG607938						
3-1/4"	HG608255						
3-1/2"	HG608890						
3-3/4"	HG609525						
3-7/8"	HG609843						
4"	HG610160						

ACCESSORY ARBOR	PART NO.
φ25mm~φ60mm: 10mm shank (from 1"~2-3/8")	AB-TS05521D6
φ61mm~φ100mm: 12mm shank (from 2-7/16"~4")	AB-TS05524D6
φ101mm~φ200mm: 13 mm shank	AB-TS05531D8

CENTER DRILL + SPRING	PART NO.
φ13mm~φ17mm (from 9/16"~11/16")	M-SP6060SSW
φ18mm~φ100mm (from 3/4"~3-7/8")	M-SP6060BBW
φ101mm~φ200mm (4")	M-SP8060HGW

CENTER DRILL	PART NO.
φ13mm~φ100mm: φ6mm×60L (from 9/16"~3-7/8")	M-CD60600
φ101mm~φ200mm: 8mm×60L (from 4")	M-CD80600

SPRING	PART NO.
φ13mm~φ17mm (from 9/16"~11/16")	M-SP6060SS
φ18mm~φ100mm (from 3/4"~3-7/8")	M-SP6060BB
φ101mm~φ200mm (4")	M-SP8060HG

5mm

HP TYPE

SHAJENG HARDWARE CO., LTD

HP TYPE

Complete with shank, center drill and ejector spring



HEAVY-DUTY

Ø 16mm ~ Ø 168mm

FEATURES

- Material: Tungsten Carbide Micro Grade
- Drilling depth: 5mm thick
- Effective length: 42mm deep

APPLICATIONS

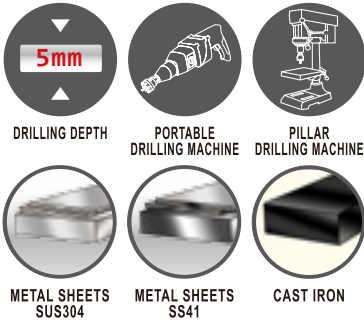

(See page 30 for more cutter's application)

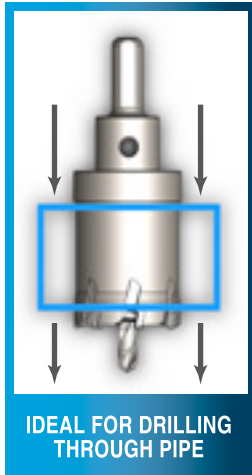

PROPERTIES



- Center drill can lead the cutter to material as well as to prevent carbide damage.



- The slug is ejected by spring when cutting is finished.



- With its extremely sharp Tungsten Carbide Tipped cutting edges, it can be run at higher feed rate and speed to create holes of exceptional precision and cleanliness.



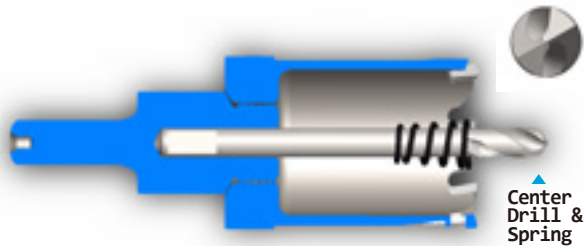
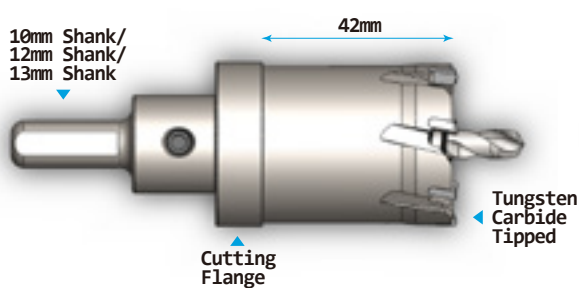

- Cutting Depth Limited to prevent over drill.

ADVANTAGES

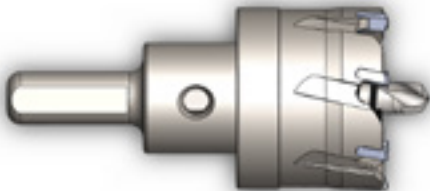

DIA.	ITEM NO.	DIA.	ITEM NO.	DIA.	ITEM NO.	DIA.	ITEM NO.	DIA.	ITEM NO.	DIA.	ITEM NO.
16mm	HP80160	28mm	HP80280	42mm	HP80420	56mm	HP80560	74mm	HP80740	105mm	HP81050
17mm	HP80170	29mm	HP80290	43mm	HP80430	57mm	HP80570	75mm	HP80750	110mm	HP81100
18mm	HP80180	30mm	HP80300	44mm	HP80440	58mm	HP80580	76mm	HP80760	114mm	HP81140
18.6mm	HP80186	31mm	HP80310	45mm	HP80450	59mm	HP80590	79mm	HP80790	115mm	HP81150
19mm	HP80190	32mm	HP80320	46mm	HP80460	60mm	HP80600	80mm	HP80800	125mm	HP81250
20mm	HP80200	33mm	HP80330	47mm	HP80470	61mm	HP80610	82mm	HP80820	127mm	HP81270
21mm	HP80210	34mm	HP80340	48mm	HP80480	62mm	HP80620	83mm	HP80830	140mm	HP81400
22mm	HP80220	35mm	HP80350	49mm	HP80490	63mm	HP80630	85mm	HP80850	146mm	HP81460
23mm	HP80230	36mm	HP80360	50mm	HP80500	64mm	HP80640	86mm	HP80860	150mm	HP81500
24mm	HP80240	37mm	HP80370	51mm	HP80510	65mm	HP80650	89mm	HP80890	168mm	HP81680
25mm	HP80250	38mm	HP80380	52mm	HP80520	68mm	HP80680	90mm	HP80900		
25.5mm	HP80255	39mm	HP80390	53mm	HP80530	69mm	HP80690	95mm	HP80950		
26mm	HP80260	40mm	HP80400	54mm	HP80540	70mm	HP80700	100mm	HP81000		
27mm	HP80270	41mm	HP80410	55mm	HP80550	72mm	HP80720	102mm	HP81020		

Features and Comparison

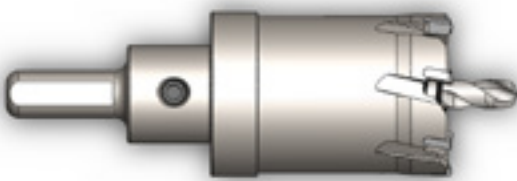
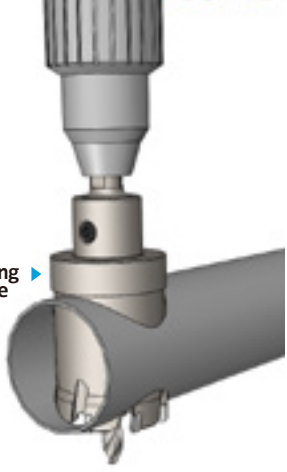
Model	Drilling depth	Effective length	Pipe
<p>HG TYPE</p>  <p>HG Type cutter can drill pipe but can't get through to pipe because of its medium cutting effective length.</p>	5mm	28mm	
<p>HP TYPE</p>  <p>HP Type cutter can drill through pipe because of its long cutting effective length.</p>	5mm	42mm	 <p>Cutting Flange</p>

DIA.	ITEM NO.	DIA.	ITEM NO.
5/8"	HP801588	1-7/8"	HP804763
11/16"	HP801746	1-15/16"	HP804921
3/4"	HP801905	2"	HP805080
13/16"	HP802064	2-1/16"	HP805239
7/8"	HP802223	2-1/8"	HP805398
15/16"	HP802381	2-3/16"	HP805556
1"	HP802540	2-1/4"	HP805715
1-1/16"	HP802699	2-5/16"	HP805874
1-1/8"	HP802858	2-3/8"	HP806033
1-3/16"	HP803016	2-7/16"	HP806191
1-1/4"	HP803175	2-1/2"	HP806350
1-5/16"	HP803334	2-9/16"	HP806509
1-3/8"	HP803493	2-5/8"	HP806668
1-7/16"	HP803651		
1-1/2"	HP803810		
1-9/16"	HP803969		
1-5/8"	HP804128		
1-11/16"	HP804286		
1-3/4"	HP804445		
1-13/16"	HP804604		

CENTER DRILL + SPRING	PART NO.
φ16mm~φ18mm (from 5/8"~11/16")	M-SP6080HPSW
φ19mm~φ64mm (from 3/4"~2-1/2")	M-SP6080HPW
φ65mm~φ168mm (from 2-9/16"~2-5/8")	M-SP8080HPW

CENTER DRILL	PART NO.
φ16mm~φ65mm: φ6mm×80L (from 5/8"~2-9/16")	M-CD60800
φ66mm~φ168mm: φ8mm×80L	M-CD80800

SPRING	PART NO.
φ16mm~φ18mm	M-SP6080HPS
φ19mm~φ64mm	M-SP6080HP
φ65 mm ~φ168mm	M-SP8080HP

ACCESSORY ARBOR	PART NO.
φ25mm~φ40mm: 10mm shank (from 1"~1-9/16")	AB-TS05521D6
φ41mm~φ64mm: 12mm shank (from 1-5/8"~2-1/2")	AB-TS05524D6
φ65mm~φ100mm: 12mm shank (from 2-9/16"~2-5/8")	AB-TS05524D8
φ101mm~φ168mm: 13mm shank	AB-TS05531D8

12mm

HK TYPE

SHAJENG HARDWARE CO., LTD

HK TYPE

Complete with pin

FEATURES

- Material: Tungsten Carbide Micro Grade
- Drilling depth: 12mm thick
- Effective length: 18mm deep

HEAVY-DUTY
 Ø 15mm ~ Ø 35mm

APPLICATIONS

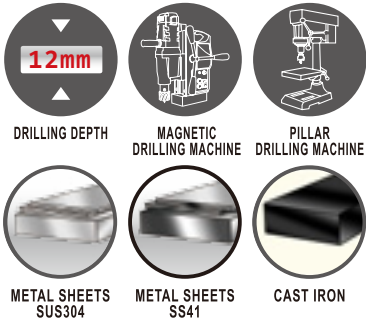

(See page 30 for more cutter's application)

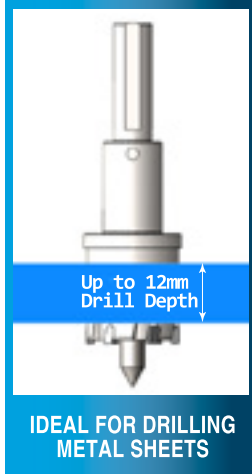

PROPERTIES



With its extremely sharp Tungsten Carbide Tipped cutting edges, it can be run at higher feed rate and speed to create holes of exceptional precision and cleanliness.

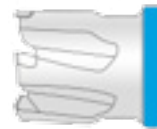

Cutting Depth Limited to prevent over drill.

ADVANTAGES

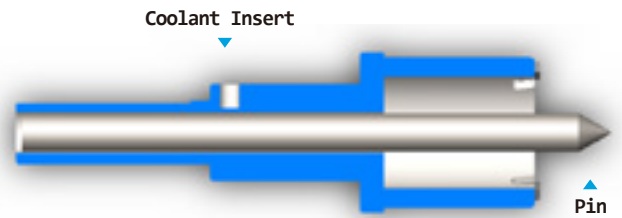
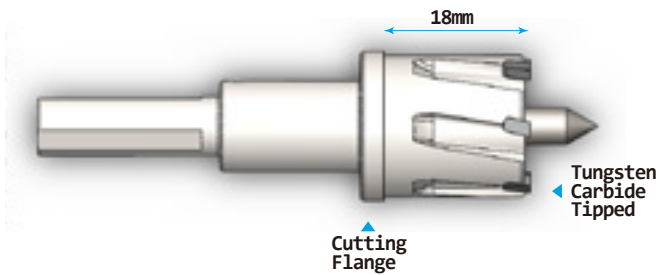

DIA.	ITEM NO.	DIA.	ITEM NO.	DIA.	ITEM NO.	DIA.	ITEM NO.
15mm	HK12150	26mm	HK12260	9/16"	HK121429	1"	HK122540
16mm	HK12160	27mm	HK12270	5/8"	HK121588	1-1/16"	HK122699
17mm	HK12170	28mm	HK12280	11/16"	HK121746	1-1/8"	HK122858
18mm	HK12180	29mm	HK12290	3/4"	HK121905	1-3/16"	HK123016
19mm	HK12190	30mm	HK12300	13/16"	HK122064	1-1/4"	HK123175
20mm	HK12200	31mm	HK12310	7/8"	HK122223	1-5/16"	HK123334
21mm	HK12210	32mm	HK12320	15/16"	HK122381	1-3/8"	HK123493
22mm	HK12220	33mm	HK12330				
23mm	HK12230	34mm	HK12340				
24mm	HK12240	35mm	HK12350				
25mm	HK12250						

APPLICABLE MACHINE

HK TYPE:

HK type is for magnetic drilling machine/ pillar drilling machine with chuck.

COOLANT TANK:

Coolant raises speed and quality of drilling.

PIN:

Pin can lead the cutter to material as well as to prevent carbide damage.

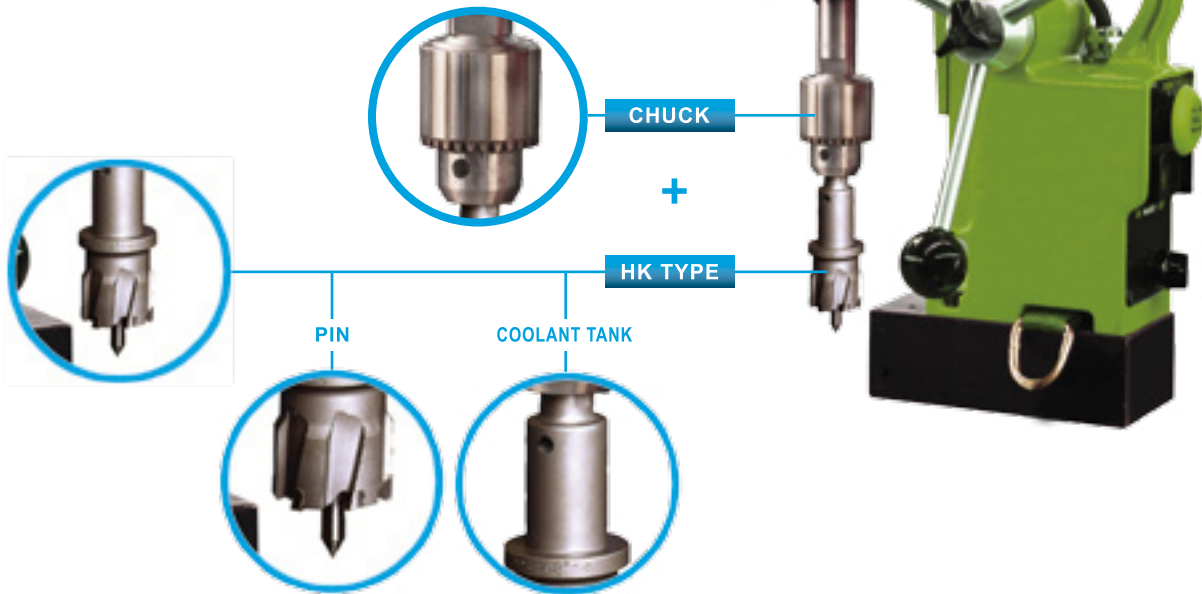

SPECIAL DESIGNED COOLANT TANK

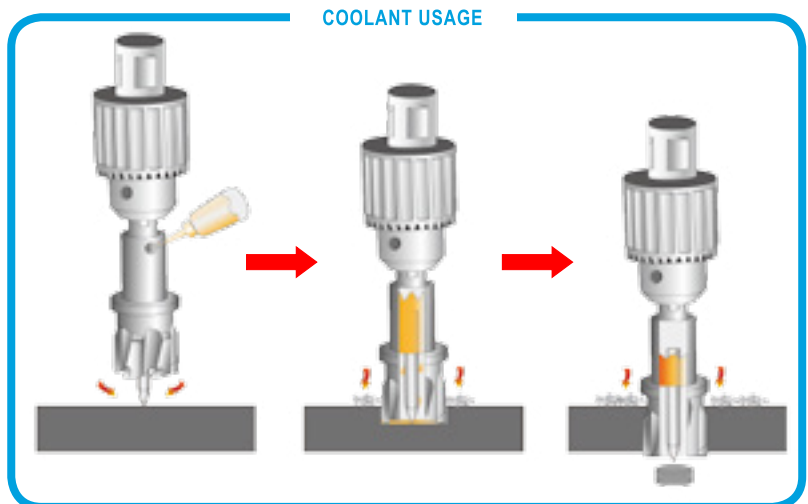
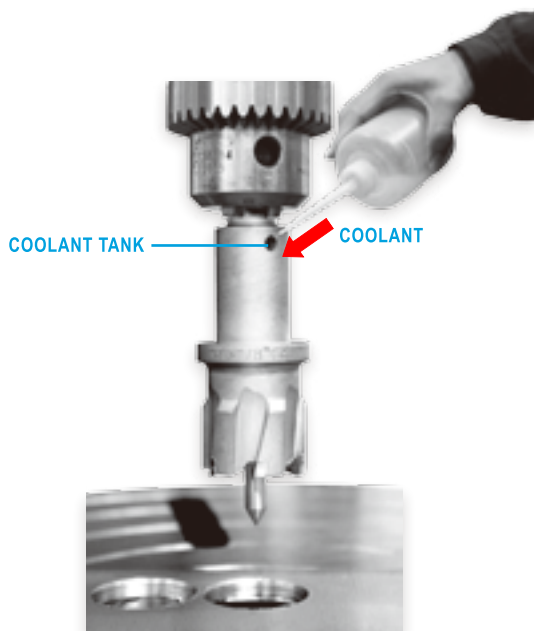

12mm

HM12 TYPE

SHAJENG HARDWARE CO., LTD

HM12 TYPE

Complete with shank and center drill



LIGHT-CUT

Ø 18mm ~ Ø 68mm

FEATURES

- Material: Tungsten Carbide Micro Grade
- Drilling depth: 12mm thick
- Effective length: 28mm deep

APPLICATIONS

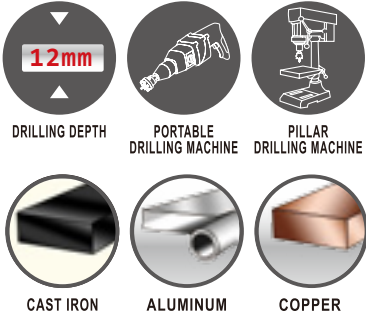

(See page 31 for more cutter's application)



IDEAL FOR DRILLING THIN METAL SHEET

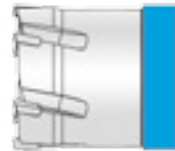

PROPERTIES



- Center drill can lead the cutter to material as well as to prevent carbide damage.



- With its extremely sharp Tungsten Carbide Tipped cutting edges, it can be run at higher feed rate and speed to create holes of exceptional precision and cleanliness.
- Multiple cutting edges make precise cutting as well as prolong product life.

- Cutting Depth Limited to prevent over drill.

ADVANTAGES

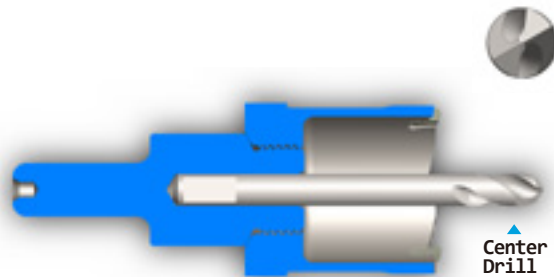
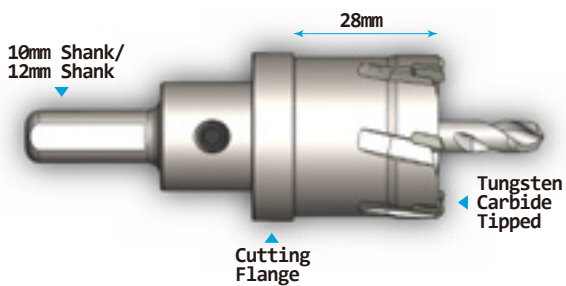

HM12 through Thick Plate

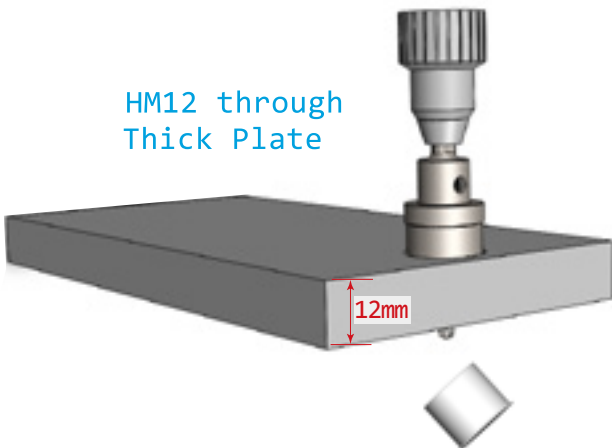

HM12 through Thin Plate

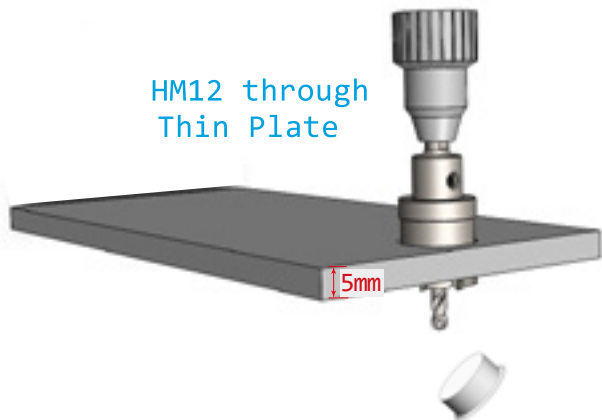

DIA.	ITEM NO.	DIA.	ITEM NO.	DIA.	ITEM NO.
18mm	HM12180	44mm	HM12440	9/16"	HM121429
19mm	HM12190	45mm	HM12450	5/8"	HM121588
20mm	HM12200	46mm	HM12460	11/16"	HM121746
21mm	HM12210	47mm	HM12470	3/4"	HM121905
22mm	HM12220	48mm	HM12480	13/16"	HM122064
23mm	HM12230	49mm	HM12490	7/8"	HM122223
24mm	HM12240	50mm	HM12500	15/16"	HM122381
25mm	HM12250	51mm	HM12510	1"	HM122540
26mm	HM12260	52mm	HM12520	1-1/16"	HM122699
27mm	HM12270	53mm	HM12530	1-1/8"	HM122858
28mm	HM12280	54mm	HM12540	1-3/16"	HM123016
29mm	HM12290	55mm	HM12550	1-7/32"	HM123096
30mm	HM12300	56mm	HM12560	1-1/4"	HM123175
31mm	HM12310	57mm	HM12570	1-5/16"	HM123334
32mm	HM12320	58mm	HM12580	1-3/8"	HM123493
33mm	HM12330	59mm	HM12590	1-7/16"	HM123651
34mm	HM12340	60mm	HM12600	1-1/2"	HM123810
35mm	HM12350	61mm	HM12610	1-9/16"	HM123969
36mm	HM12360	62mm	HM12620	1-5/8"	HM124128
37mm	HM12370	63mm	HM12630	1-11/16"	HM124286
38mm	HM12380	64mm	HM12640	1-3/4"	HM124445
39mm	HM12390	65mm	HM12650	1-13/16"	HM124604
40mm	HM12400	66mm	HM12660	1-7/8"	HM124763
41mm	HM12410	67mm	HM12670	1-15/16"	HM124921
42mm	HM12420	68mm	HM12680	2"	HM125080
43mm	HM12430			2-1/16"	HM125239
				2-1/8"	HM125398
				2-3/16"	HM125556
				2-1/4"	HM125715
				2-5/16"	HM125874
				2-3/8"	HM126033
				2-7/16"	HM126191
				2-1/2"	HM126350

ACCESSORY ARBOR	PART NO.
φ25mm~φ40mm: 10mm shank (from 1"~1-9/16")	AB-TS05521D6
φ41mm~φ68mm: 12mm shank (from 1-5/8"~2-1/2")	AB-TS05524D6

CENTER DRILL	PART NO.
φ18mm~φ68mm: φ6mm×70L (from 5/8"~2-1/2")	M-CD6070T



25mm

HM25 TYPE

SHAJENG HARDWARE CO., LTD

HM25 TYPE

Complete with shank and center drill



LIGHT-CUT
Ø 15mm ~ Ø 80mm

FEATURES

- Material: Tungsten Carbide Micro Grade
- Drilling depth: 25mm thick
- Effective length: 35mm deep

APPLICATIONS



DRILLING DEPTH



PORTABLE DRILLING MACHINE



PILLAR DRILLING MACHINE



METAL SHEETS
SS41



CAST IRON



FIBER GLASS

(See page 31 for more cutter's application)



IDEAL FOR DRILLING METAL SHEET



PROPERTIES



- Center drill can lead the cutter to material as well as to prevent carbide damage.

- With its extremely sharp Tungsten Carbide Tipped cutting edges, it can be run at higher feed rate and speed to create holes of exceptional precision and cleanliness.

- Cutting Depth Limited to prevent over drill.

ADVANTAGES

10mm Shank/
12mm Shank

35mm

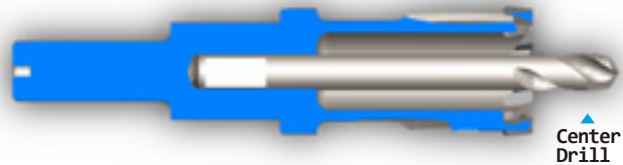
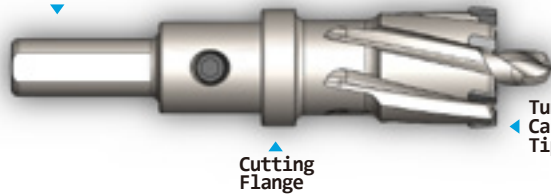

HM25 through Thick Plate

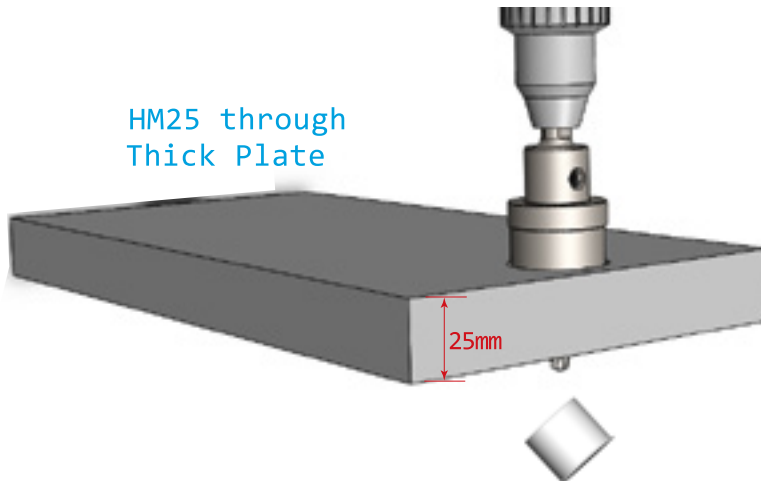

DIA.	ITEM NO.	DIA.	ITEM NO.	DIA.	ITEMNO.
15mm	HM25150	41mm	HM25410	5/8"	HM251588
16mm	HM25160	42mm	HM25420	11/16"	HM251746
17mm	HM25170	43mm	HM25430	3/4"	HM251905
18mm	HM25180	44mm	HM25440	13/16"	HM252064
19mm	HM25190	45mm	HM25450	7/8"	HM252223
20mm	HM25200	46mm	HM25460	15/16"	HM252381
21mm	HM25210	47mm	HM25470	1"	HM252540
22mm	HM25220	48mm	HM25480	1-1/16"	HM252699
23mm	HM25230	49mm	HM25490	1-1/8"	HM252858
24mm	HM25240	50mm	HM25500	1-3/16"	HM253016
25mm	HM25250	51mm	HM25510	1-1/4"	HM253175
26mm	HM25260	52mm	HM25520	1-5/16"	HM253334
27mm	HM25270	53mm	HM25530	1-3/8"	HM253493
28mm	HM25280	54mm	HM25540	1-7/16"	HM253651
29mm	HM25290	55mm	HM25550	1-1/2"	HM253810
30mm	HM25300	56mm	HM25560	1-9/16"	HM253969
31mm	HM25310	57mm	HM25570	1-5/8"	HM254128
32mm	HM25320	58mm	HM25580	1-11/16"	HM254286
33mm	HM25330	59mm	HM25590	1-3/4"	HM254445
34mm	HM25340	60mm	HM25600	1-13/16"	HM254604
35mm	HM25350	61mm	HM25610	1-7/8"	HM254763
36mm	HM25360	62mm	HM25620	1-15/16"	HM254921
37mm	HM25370	63mm	HM25630	2"	HM255080
38mm	HM25380	64mm	HM25640	2-1/16"	HM255239
39mm	HM25390	65mm	HM25650	2-1/8"	HM255398
40mm	HM25400	80mm	HM25800	2-3/16"	HM255556
				2-1/4"	HM255715
				2-5/16"	HM255874
				2-3/8"	HM256033
				2-7/16"	HM256191
				2-1/2"	HM256350

CENTER DRILL	PART NO.
φ15mm~φ80mm: φ6mm×75L (from 11/16"~2-1/2")	M-CD6075T

TCT HOLE SAW / HM25 TYPE

PL TYPE

Complete with shank and center drill

FEATURES

- Material: Tungsten Carbide Micro Grade
- Drilling depth: 5mm thick
- Effective length: 22mm deep

SUPER LIGHT-CUT
 ϕ 16mm ~ ϕ 65mm

Economical Type TCT Hole Saw



- With its extremely sharp Tungsten Carbide Tipped cutting edges, it can be run at higher feed rate and speed to create holes of exceptional precision and cleanliness.

APPLICATIONS

5mm
 DRILLING DEPTH PORTABLE DRILLING MACHINE PILLAR DRILLING MACHINE
 ALUMINUM PVC PIPES COPPER

(See page 30 for more cutter's application)

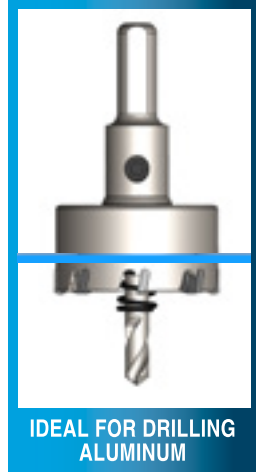

PROPERTIES



- Center drill can lead the cutter to material as well as to prevent carbide damage.



- The slug is ejected by spring when cutting is finished.

ADVANTAGES

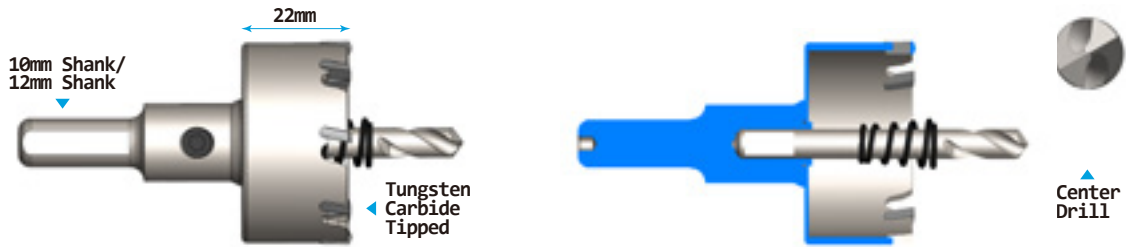

DIA.	ITEM NO.	DIA.	ITEM NO.	DIA	PART NO.
16mm	PL20160	35mm	PL20350	7/8"	PL202223
18mm	PL20180	36mm	PL20360	1-1/8"	PL202858
19mm	PL20190	38mm	PL20380	1-3/8"	PL203493
20mm	PL20200	40mm	PL20400		
21mm	PL20210	42mm	PL20420		
22mm	PL20220	45mm	PL20450		
24mm	PL20240	48mm	PL20480		
25mm	PL20250	50mm	PL20500		
26mm	PL20260	52mm	PL20520		
28mm	PL20280	55mm	PL20550		
30mm	PL20300	58mm	PL20580		
32mm	PL20320	60mm	PL20600		
34mm	PL20340	65mm	PL20650		

CENTER DRILL	PART NO.
ϕ 16mm~ ϕ 65mm: ϕ 6mm \times 60L	M-CD60600

SPRING	PART NO.
ϕ 16mm~ ϕ 65mm	M-SP6060PL

CENTER DRILL + SPRING	PART NO.
ϕ 16mm~ ϕ 65mm	M-SP6060PLW

HN TYPE

Complete with shank and center drill

FEATURES

- Material: Tungsten Carbide Micro Grade
- Drilling depth: 25mm thick
- Effective length: 35mm deep

SUPER LIGHT-CUT

Ø 19mm ~ Ø 65mm

APPLICATIONS

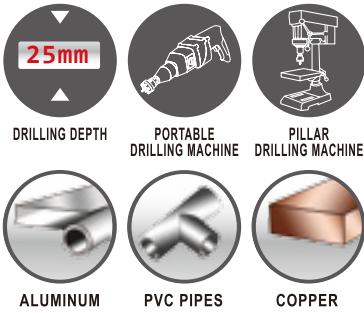

(See page 31 for more cutter's application)

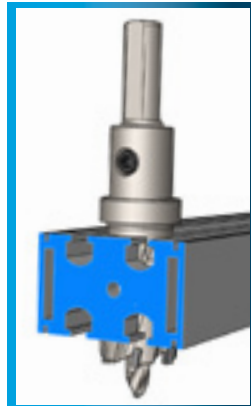

IDEAL FOR DRILLING ALUMINUM



PROPERTIES



- Center drill can lead the cutter to material as well as to prevent carbide damage.
- With its extremely sharp Tungsten Carbide Tipped cutting edges, it can be run at higher feed rate and speed to create holes of exceptional precision and cleanliness.
- Cutting Depth Limited to prevent over drill.

10mm Shank/
12mm Shank

35mm

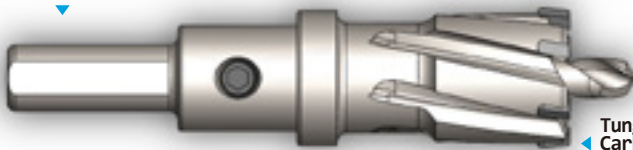

Cutting Flange

Tungsten Carbide Tipped

CENTER DRILL

PART NO.

φ19mm~φ65mm: φ6mm×80L
(from 3/4"~2-1/2")

M-CD6080T

DIA.	ITEM NO.	DIA.	ITEM NO.	DIA.	ITEM NO.
19mm	HN25190	34mm	HN25340	50mm	HN25500
20mm	HN25200	35mm	HN25350	51mm	HN25510
21mm	HN25210	36mm	HN25360	52mm	HN25520
22mm	HN25220	37mm	HN25370	53mm	HN25530
23mm	HN25230	38mm	HN25380	54mm	HN25540
24mm	HN25240	39mm	HN25390	55mm	HN25550
25mm	HN25250	40mm	HN25400	56mm	HN25560
26mm	HN25260	41mm	HN25410	57mm	HN25570
27mm	HN25270	42mm	HN25420	58mm	HN25580
28mm	HN25280	43mm	HN25430	59mm	HN25590
29mm	HN25290	44mm	HN25440	60mm	HN25600
30mm	HN25300	45mm	HN25450	61mm	HN25610
31mm	HN25310	46mm	HN25460	62mm	HN25620
32mm	HN25320	47mm	HN25470	63mm	HN25630
33mm	HN25330	48mm	HN25480	64mm	HN25640
34mm	HN25340	49mm	HN25490	65mm	HN25650

DIA.	ITEM NO.	DIA.	ITEM NO.
3/4"	HN251905	1-11/16"	HN254286
13/16"	HN252064	1-3/4"	HN254445
7/8"	HN252223	1-13/16"	HN254604
15/16"	HN252381	1-7/8"	HN254763
1"	HN252540	1-15/16"	HN254921
1-1/16"	HN252699	2"	HN255080
1-1/8"	HN252858	2-1/16"	HN255239
1-3/16"	HN253016	2-1/8"	HN255398
1-1/4"	HN253175	2-3/16"	HN255556
1-5/16"	HN253334	2-1/4"	HN255715
1-3/8"	HN253493	2-5/16"	HN255874
1-7/16"	HN253651	2-3/8"	HN256033
1-1/2"	HN253810	2-7/16"	HN256191
1-9/16"	HN253969	2-1/2"	HN256350
1-5/8"	HN254128		
1-11/16"	HN254286		

5mm

HRF TYPE

SHAJENG HARDWARE CO., LTD

HRF TYPE

With **UNIVERSAL ARBORS** for different kinds of drilling machines

FEATURES

- Material: Tungsten Carbide Micro Grade
- Drilling depth: 5mm thick
- Effective length: 12mm deep



APPLICATIONS

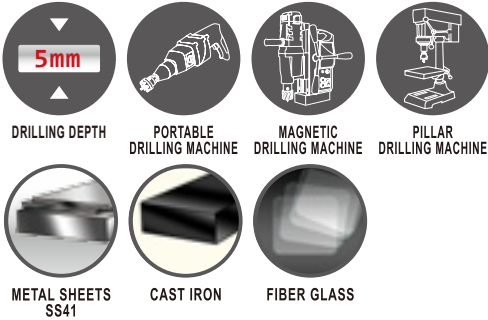

(See page 31 for more cutter's application)

PROPERTIES



With its extremely sharp Tungsten Carbide Tipped cutting edges, it can be run at higher feed rate and speed to create holes of exceptional precision and cleanliness.



Cutting Depth Limited to prevent over drill.

LIGHT-CUT

Ø 14mm ~ Ø 120mm



ADVANTAGES

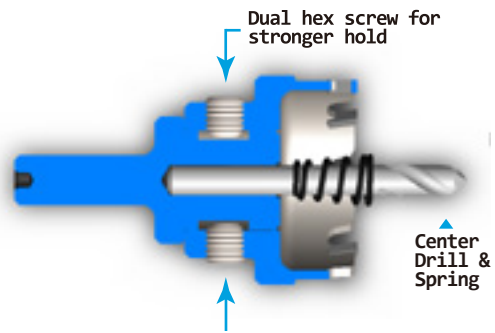
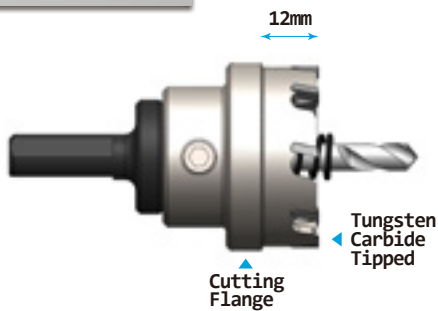

Thin Plate

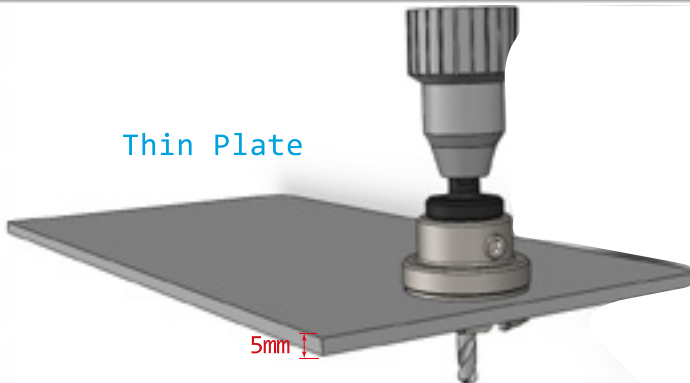

DIA	PART NO.	DIA	PART NO.
14mm	HRF50140	25mm	HRF50250
15mm	HRF50150	26mm	HRF50260
16mm	HRF50160	27mm	HRF50270
17mm	HRF50170	28mm	HRF50280
18mm	HRF50180	29mm	HRF50290
19mm	HRF50190	30mm	HRF50300
20mm	HRF50200	31mm	HRF50310
21mm	HRF50210	32mm	HRF50320
22mm	HRF50220	33mm	HRF50330
23mm	HRF50230	34mm	HRF50340
24mm	HRF50240	35mm	HRF50350

DIA	PART NO.	DIA	PART NO.	DIA	PART NO.	DIA	PART NO.
36mm	HRF50360	47mm	HRF50470	58mm	HRF50580	69mm	HRF50690
37mm	HRF50370	48mm	HRF50480	59mm	HRF50590	70mm	HRF50700
38mm	HRF50380	49mm	HRF50490	60mm	HRF50600	75mm	HRF50750
39mm	HRF50390	50mm	HRF50500	61mm	HRF50610	80mm	HRF50800
40mm	HRF50400	51mm	HRF50510	62mm	HRF50620	85mm	HRF50850
41mm	HRF50410	52mm	HRF50520	63mm	HRF50630	90mm	HRF50900
42mm	HRF50420	53mm	HRF50530	64mm	HRF50640	100mm	HRF51000
43mm	HRF50430	54mm	HRF50540	65mm	HRF50650	105mm	HRF51050
44mm	HRF50440	55mm	HRF50550	66mm	HRF50660	110mm	HRF51100
45mm	HRF50450	56mm	HRF50560	67mm	HRF50670	115mm	HRF51150
46mm	HRF50460	57mm	HRF50570	68mm	HRF50680	120mm	HRF51200

ACCESSORY

Portable drilling machines

<p>9mm</p> <p>Art No. AB-TS1005420D6</p>	+	<p>φ14 - 60mm</p>	+	<p>φ6mm x 60L</p>	=	
<p>11mm</p> <p>Art No. AB-TS1305420D6</p>	+	<p>φ61 - 120mm</p>	+	<p>φ6mm x 60L</p>	=	

Magnetic drilling machines

<p>Fein Shank Art No. AD-40458F</p>	+	<p>φ14 - 120mm</p>	+	<p>φ6.35mm x 100L</p>	=	
<p>One-Touch Shank Art No. AD-304580</p>	+	<p>φ14 - 120mm</p>	+	<p>φ6.35mm x 100L</p>	=	
<p>Weldon Shank Art No. AD-20458W</p>	+	<p>φ14 - 120mm</p>	+	<p>φ6.35mm x 100L</p>	=	

Pillar drilling machines

<p>MT2 Art No. MT2020110</p>	+	<p>φ14 - 120mm</p>	+	<p>φ6mm x 60L</p>	=	
<p>MT3 Art No. MT3020129</p>	+	<p>φ14 - 120mm</p>	+	<p>φ6mm x 60L</p>	=	
<p>Art No. MT2020110S</p>	+	<p>φ14 - 120mm</p>	+	<p>φ6mm x 60L</p>	=	
<p>Art No. MT3020129S</p>	+	<p>φ14 - 120mm</p>	+	<p>φ6mm x 60L</p>	=	

5 mm

HRP TYPE

SHAJENG HARDWARE CO., LTD

HRP TYPE

With **UNIVERSAL ARBORS** for different kinds of drilling machines



FEATURES

- Material: Tungsten Carbide Micro Grade
- Drilling depth: 5mm, 10mm thick
- Effective length: 50mm, 100mm deep

LIGHT-CUT
 \varnothing 14mm ~ \varnothing 200mm

APPLICATIONS

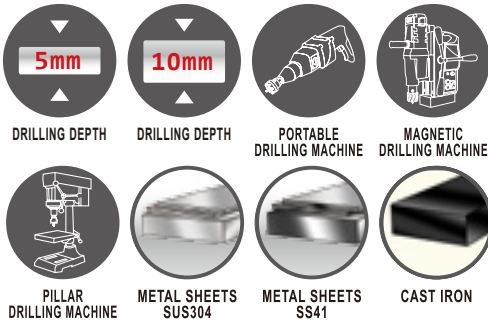

(See page 31 for more cutter's application)



PROPERTIES



With its extremely sharp Tungsten Carbide Tipped cutting edges, it can be run at higher feed rate and speed to create holes of exceptional precision and cleanliness.

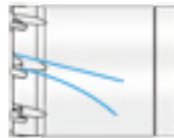

Smooth Flutes for easy chips removal.



Cutting Depth Limited to prevent over drill.

HRP50 TYPE

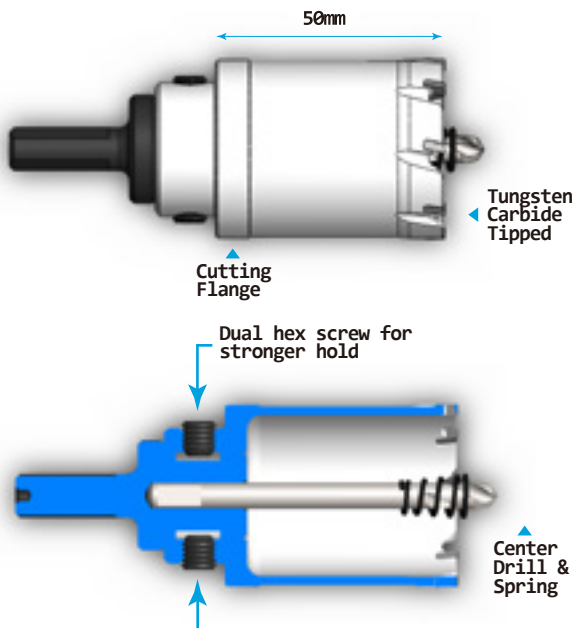

HRP100 TYPE

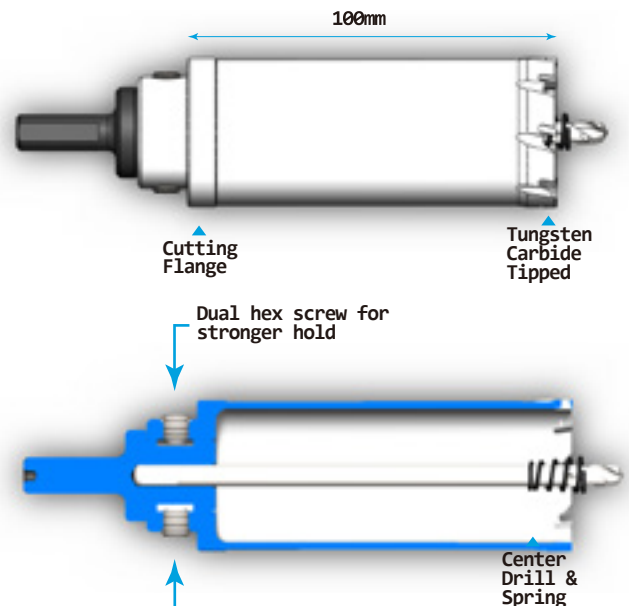

ACCESSORY

Portable drilling machines

	<p>9mm</p> <p>Art No. AB-TS1005420D6</p>	+	<p>φ14 - 60mm</p>	+	<p>φ6mm x 90L</p>	=	
	<p>11mm</p> <p>Art No. AB-TS1305420D6</p>	+	<p>φ61 - 100mm</p>	+	<p>φ6mm x 90L</p>	=	

Magnetic drilling machines

	<p>Fein Shank Art No. AD-40458F</p>	+	<p>φ14 - 100mm</p>	+	<p>φ6.35mm x 100L</p>	=	
	<p>One-Touch Shank Art No. AD-304580</p>						
	<p>Weldon Shank Art No. AD-20458W</p>						

Pillar drilling machines

	<p>MT2 Art No. MT2020110</p>	+	<p>φ14 - 100mm</p>	+	<p>φ6mm x 90L</p>	=	
	<p>MT3 Art No. MT3020129</p>				<p>φ6mm x 90L</p>		
	<p>Art No. MT2020110S</p>	+	<p>φ14 - 100mm</p>	=			
	<p>Art No. MT3020129S</p>						
	<p>MT3 Art No. MT3032129</p>	+	<p>φ105 - 200mm</p>	+	<p>φ6mm x 90L</p>	=	
	<p>MT4 Art No. MT4032148</p>				<p>φ6mm x 90L</p>		



5 mm

HRP TYPE

SHAJIENG HARDWARE CO., LTD

HRP50 TYPE

MAX: \varnothing 200mm

HRP50

HRP50 TYPE can drill holes up to \varnothing 50mm material.

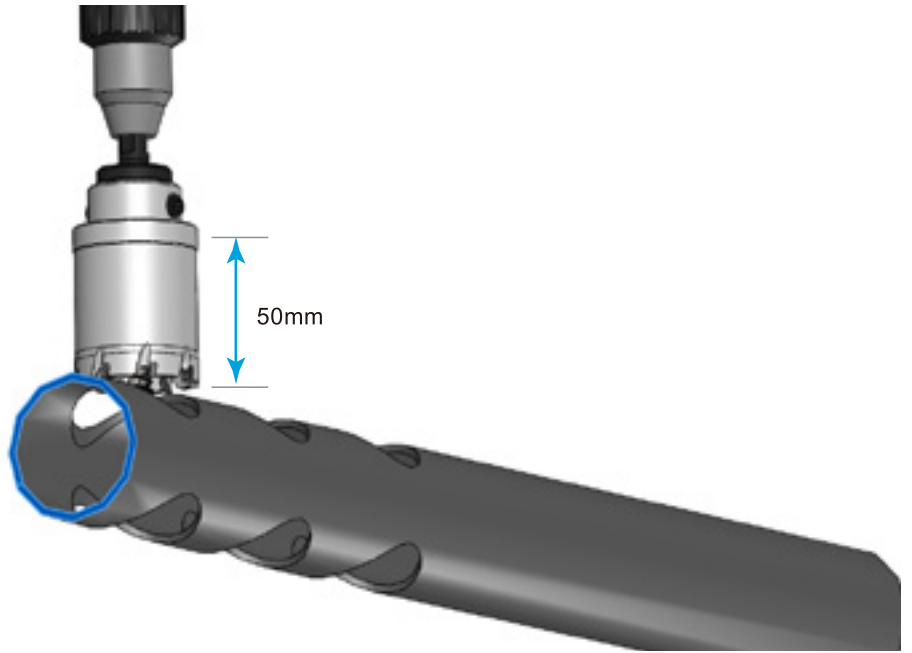

HRP100 TYPE

MAX: \varnothing 250mm

HRP100

HRP100 TYPE can drill holes up to \varnothing 100mm material.

100mm

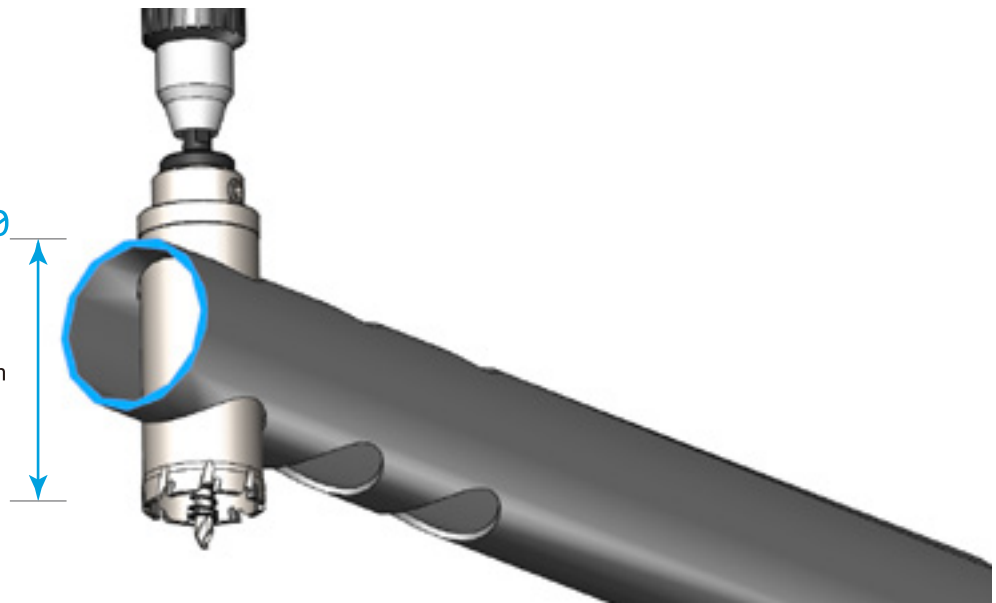

HRP50

DIA	PART NO.	DIA	PART NO.	DIA	PART NO.	DIA	PART NO.	DIA	PART NO.
14mm	HRP80140	29mm	HRP80290	44mm	HRP80440	59mm	HRP80590	90mm	HRP80900
15mm	HRP80150	30mm	HRP80300	45mm	HRP80450	60mm	HRP80600	100mm	HRP81000
16mm	HRP80160	31mm	HRP80310	46mm	HRP80460	61mm	HRP80610	105mm	HRP81050
17mm	HRP80170	32mm	HRP80320	47mm	HRP80470	62mm	HRP80620	110mm	HRP81100
18mm	HRP80180	33mm	HRP80330	48mm	HRP80480	63mm	HRP80630	115mm	HRP81150
19mm	HRP80190	34mm	HRP80340	49mm	HRP80490	64mm	HRP80640	120mm	HRP81200
20mm	HRP80200	35mm	HRP80350	50mm	HRP80500	65mm	HRP80650	130mm	HRP81300
21mm	HRP80210	36mm	HRP80360	51mm	HRP80510	66mm	HRP80660	140mm	HRP81400
22mm	HRP80220	37mm	HRP80370	52mm	HRP80520	67mm	HRP80670	150mm	HRP81500
23mm	HRP80230	38mm	HRP80380	53mm	HRP80530	68mm	HRP80680	160mm	HRP81600
24mm	HRP80240	39mm	HRP80390	54mm	HRP80540	69mm	HRP80690	170mm	HRP81700
25mm	HRP80250	40mm	HRP80400	55mm	HRP80550	70mm	HRP80700	180mm	HRP81800
26mm	HRP80260	41mm	HRP80410	56mm	HRP80560	75mm	HRP80750	190mm	HRP81900
27mm	HRP80270	42mm	HRP80420	57mm	HRP80570	80mm	HRP80800	200mm	HRP82000
28mm	HRP80280	43mm	HRP80430	58mm	HRP80580	85mm	HRP80850		

HRP100

DIA	PART NO.	DIA	PART NO.	DIA	PART NO.	DIA	PART NO.	DIA	PART NO.
14mm	HRP1000140	29mm	HRP1000290	44mm	HRP1000440	59mm	HRP1000590	90mm	HRP1000900
15mm	HRP1000150	30mm	HRP1000300	45mm	HRP1000450	60mm	HRP1000600	100mm	HRP1001000
16mm	HRP1000160	31mm	HRP1000310	46mm	HRP1000460	61mm	HRP1000610	105mm	HRP1001050
17mm	HRP1000170	32mm	HRP1000320	47mm	HRP1000470	62mm	HRP1000620	110mm	HRP1001100
18mm	HRP1000180	33mm	HRP1000330	48mm	HRP1000480	63mm	HRP1000630	115mm	HRP1001150
19mm	HRP1000190	34mm	HRP1000340	49mm	HRP1000490	64mm	HRP1000640	120mm	HRP1001200
20mm	HRP1000200	35mm	HRP1000350	50mm	HRP1000500	65mm	HRP1000650	130mm	HRP1001300
21mm	HRP1000210	36mm	HRP1000360	51mm	HRP1000510	66mm	HRP1000660	140mm	HRP1001400
22mm	HRP1000220	37mm	HRP1000370	52mm	HRP1000520	67mm	HRP1000670	150mm	HRP1001500
23mm	HRP1000230	38mm	HRP1000380	53mm	HRP1000530	68mm	HRP1000680	160mm	HRP1001600
24mm	HRP1000240	39mm	HRP1000390	54mm	HRP1000540	69mm	HRP1000690	170mm	HRP1001700
25mm	HRP1000250	40mm	HRP1000400	55mm	HRP1000550	70mm	HRP1000700	180mm	HRP1001800
26mm	HRP1000260	41mm	HRP1000410	56mm	HRP1000560	75mm	HRP1000750	190mm	HRP1001900
27mm	HRP1000270	42mm	HRP1000420	57mm	HRP1000570	80mm	HRP1000800	200mm	HRP1002000
28mm	HRP1000280	43mm	HRP1000430	58mm	HRP1000580	85mm	HRP1000850		



10
mm

TCT HOLE SAW / HRP TYPE

25
MM

HRM TYPE

SHAJENG HARDWARE CO., LTD

HRM TYPE

With **UNIVERSAL ARBOR** for different kinds of drilling machines



FEATURES

- Material: Tungsten Carbide Micro Grade
- Drilling depth: 25mm, 50mm thick
- Effective length: 30mm, 55 mm deep

HEAVY-DUTY
Ø 14mm ~ Ø 120mm



APPLICATIONS

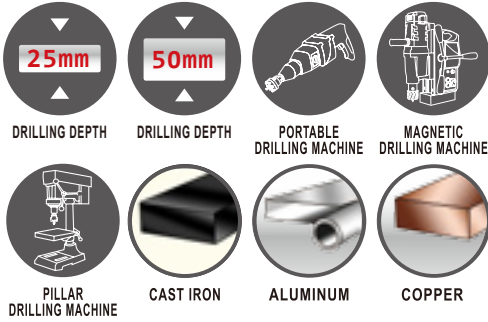

(See page 31 for more cutter's application)

PROPERTIES

With its extremely sharp Tungsten Carbide Tipped cutting edges, it can be run at higher feed rate and speed to create holes of exceptional precision and cleanliness.

Wide Flutes for easy chips removal.

Cutting Depth Limited to prevent over drill.

HRM25 TYPE

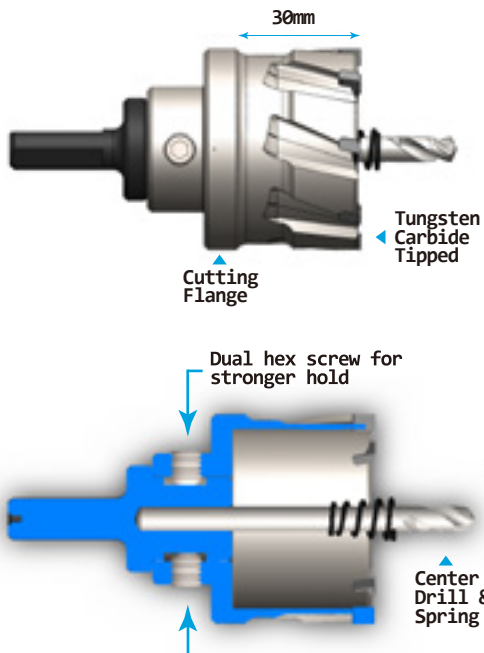

HRM50 TYPE

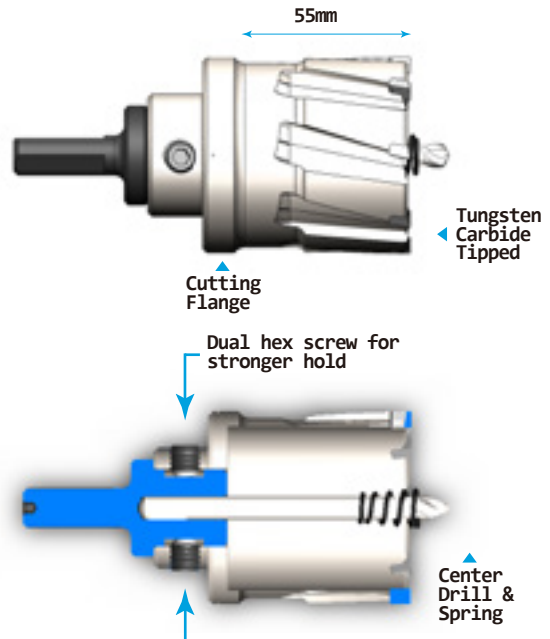

ACCESSORY

<p>Portable drilling machines</p>	<p>9mm</p> <p>Art No. AB-TS1005420D6</p>	+	<p>φ14 - 60mm</p>	+	<p>φ6mm x 75L</p>	=	
	<p>11mm</p> <p>Art No. AB-TS1305420D6</p>	+	<p>φ61 - 120mm</p>	+		=	

<p>Magnetic drilling machines</p>	<p>Fein Shank Art No. AD-40458F</p>	+	<p>φ14 - 120mm</p>	+	<p>φ6.35mm x 100L</p>	=	
	<p>One-Touch Shank Art No. AD-304580</p>						
	<p>Weldon Shank Art No. AD-20458W</p>						

<p>Pillar drilling machines</p>	<p>MT2 Art No. MT2020110</p>	+	<p>φ14 - 120mm</p>	+	<p>φ6mm x 75L</p>	=	
	<p>MT3 Art No. MT3020129</p>	+	<p>φ14 - 120mm</p>	+			
	<p>Art No. MT2020110S</p>	+	<p>φ14 - 120mm</p>	+		=	
	<p>Art No. MT3020129S</p>	+	<p>φ14 - 120mm</p>	+		=	



25
MM

HRM
TYPE

SHAJIENG
HARDWARE
CO., LTD

HRM25 TYPE

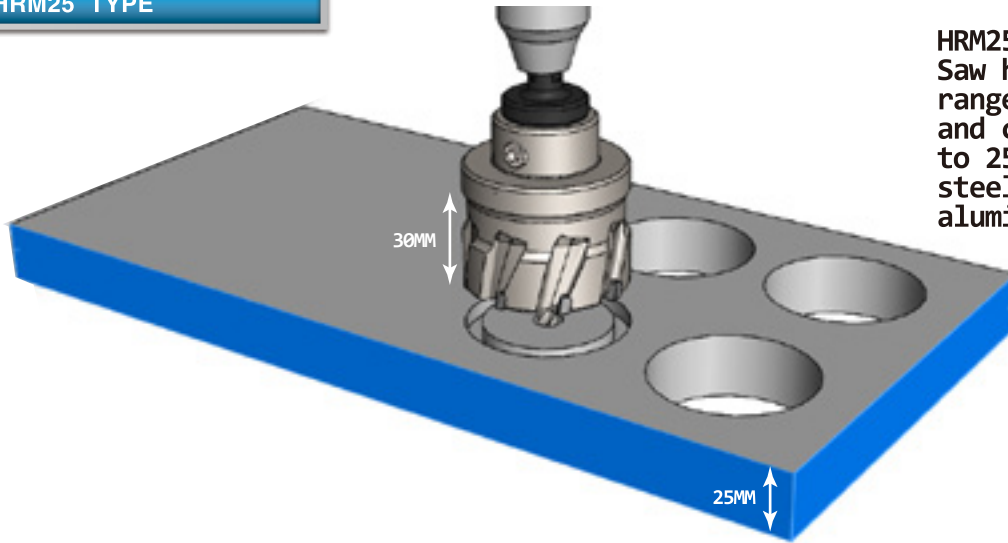

HRM25 Type Hole Saw has a diameter range up to 120 mm and can drill up to 25 mm stainless steel, metal sheets, aluminum, etc.

HRM50 TYPE

HRM50 Type Hole Saw has a diameter range up to 120 mm and can drill up to 50 mm stainless steel, metal sheets, aluminum, etc.

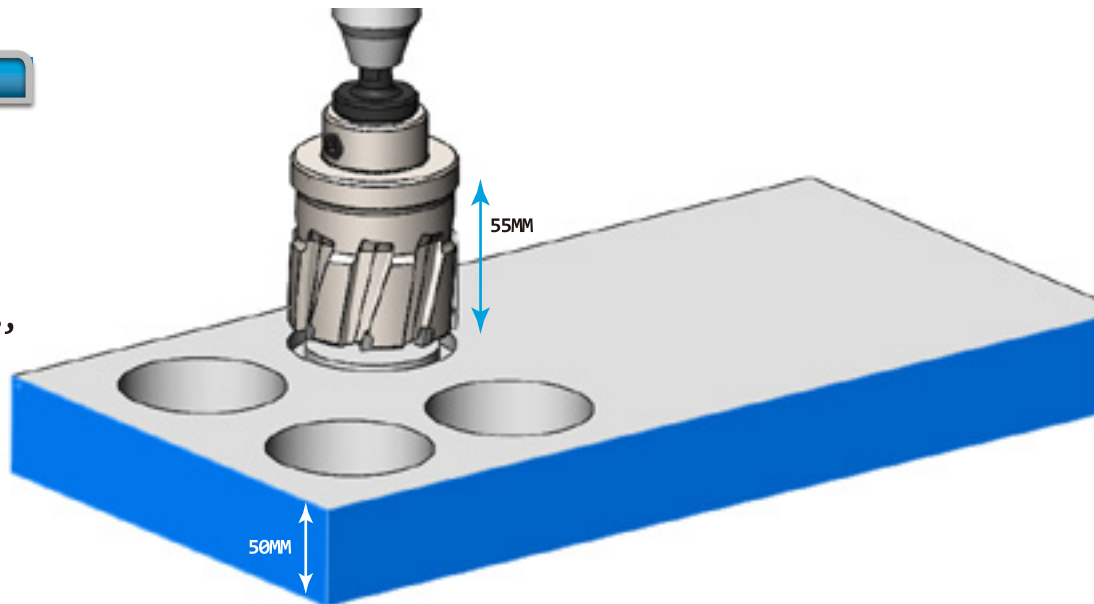

HRM25

DIA	PART NO.	DIA	PART NO.	DIA	PART NO.	DIA	PART NO.	DIA	PART NO.
14mm	HRM250140	28mm	HRM250280	42mm	HRM250420	56mm	HRM250560	70mm	HRM250700
15mm	HRM250150	29mm	HRM250290	43mm	HRM250430	57mm	HRM250570	75mm	HRM250750
16mm	HRM250160	30mm	HRM250300	44mm	HRM250440	58mm	HRM250580	76mm	HRM250760
17mm	HRM250170	31mm	HRM250310	45mm	HRM250450	59mm	HRM250590	77mm	HRM250770
18mm	HRM250180	32mm	HRM250320	46mm	HRM250460	60mm	HRM250600	78mm	HRM250780
19mm	HRM250190	33mm	HRM250330	47mm	HRM250470	61mm	HRM250610	80mm	HRM250800
20mm	HRM250200	34mm	HRM250340	48mm	HRM250480	62mm	HRM250620	85mm	HRM250850
21mm	HRM250210	35mm	HRM250350	49mm	HRM250490	63mm	HRM250630	90mm	HRM250900
22mm	HRM250220	36mm	HRM250360	50mm	HRM250500	64mm	HRM250640	95mm	HRM250950
23mm	HRM250230	37mm	HRM250370	51mm	HRM250510	65mm	HRM250650	100mm	HRM251000
24mm	HRM250240	38mm	HRM250380	52mm	HRM250520	66mm	HRM250660	105mm	HRM251050
25mm	HRM250250	39mm	HRM250390	53mm	HRM250530	67mm	HRM250670	110mm	HRM251100
26mm	HRM250260	40mm	HRM250400	54mm	HRM250540	68mm	HRM250680	115mm	HRM251150
27mm	HRM250270	41mm	HRM250410	55mm	HRM250550	69mm	HRM250690	120mm	HRM251200

HRM50

DIA	PART NO.	DIA	PART NO.	DIA	PART NO.	DIA	PART NO.	DIA	PART NO.
14mm	HRM500140	28mm	HRM500280	42mm	HRM500420	56mm	HRM500560	70mm	HRM500700
15mm	HRM500150	29mm	HRM500290	43mm	HRM500430	57mm	HRM500570	75mm	HRM500750
16mm	HRM500160	30mm	HRM500300	44mm	HRM500440	58mm	HRM500580	76mm	HRM500760
17mm	HRM500170	31mm	HRM500310	45mm	HRM500450	59mm	HRM500590	77mm	HRM500770
18mm	HRM500180	32mm	HRM500320	46mm	HRM500460	60mm	HRM500600	78mm	HRM500780
19mm	HRM500190	33mm	HRM500330	47mm	HRM500470	61mm	HRM500610	80mm	HRM500800
20mm	HRM500200	34mm	HRM500340	48mm	HRM500480	62mm	HRM500620	85mm	HRM500850
21mm	HRM500210	35mm	HRM500350	49mm	HRM500490	63mm	HRM500630	90mm	HRM500900
22mm	HRM500220	36mm	HRM500360	50mm	HRM500500	64mm	HRM500640	95mm	HRM500950
23mm	HRM500230	37mm	HRM500370	51mm	HRM500510	65mm	HRM500650	100mm	HRM501000
24mm	HRM500240	38mm	HRM500380	52mm	HRM500520	66mm	HRM500660	105mm	HRM501050
25mm	HRM500250	39mm	HRM500390	53mm	HRM500530	67mm	HRM500670	110mm	HRM501100
26mm	HRM500260	40mm	HRM500400	54mm	HRM500540	68mm	HRM500680	115mm	HRM501150
27mm	HRM500270	41mm	HRM500410	55mm	HRM500550	69mm	HRM500690	120mm	HRM501200

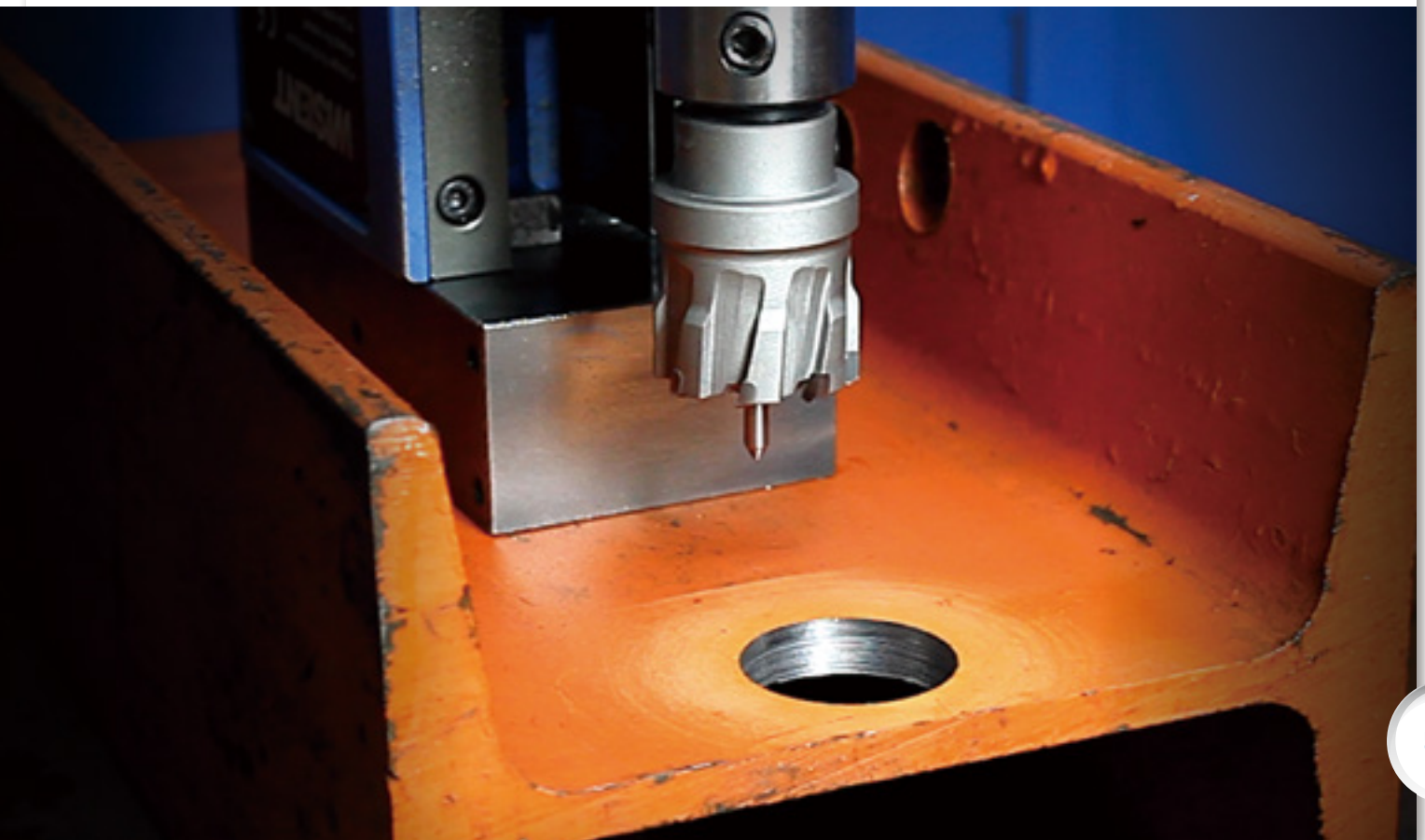

50
mm

TCT HOLE SAW / HRM TYPE



HW60 TYPE

IDEAL FOR
WOOD WORKING

FEATURES

- Material: Tungsten Carbide Micro Grade
- Drilling depth: 60mm thick
- Effective length: 70mm deep



TCT teeth for outstanding cutting performance



Deep and wide gullets for easy plug removal



Quick and easy installation of spade bit arbor



APPLICATIONS



DRILLING DEPTH



PORTABLE DRILLING MACHINE



PILLAR DRILLING MACHINE



WOOD



WOOD WITH NAILS



FIBER GLASS

(See page 31 for more cutter's application)

ADVANTAGES

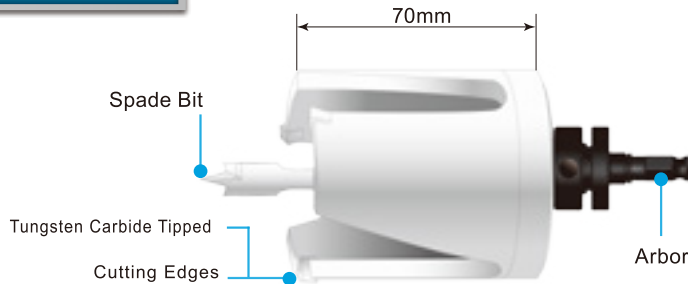

Best suits our standard arbor and spade bit



Arbor 1/2"-20 thread with one spade bit
Hole saw size: 7/8" ~ 1-3/4" (22mm~44.9mm)
Spade Bit: 3/8" x 114L

Arbor 5/8"-18 thread with one spade bit
Hole saw size: 1-7/8" ~ 6" (45mm~160mm)
Spade Bit: 3/8" x 114L

Using Guide

1. Twist the lower part of the arbor until it locked.
2. Twist the upper part of the arbor until it locked.
3. Make sure both tubes inserted on the both holes.
4. The Arbor is completely locked on the holesaw.

DIA.	PART NO.	DIA.	PART NO.	DIA.	PART NO.	DIA.	PART NO.
7/8"	HW602223	22mm	HW60220	47mm	HW60470	72mm	HW60720
15/16"	HW602381	23mm	HW60230	48mm	HW60480	73mm	HW60730
1"	HW602540	24mm	HW60240	49mm	HW60490	74mm	HW60740
1-1/16"	HW602699	25mm	HW60250	50mm	HW60500	75mm	HW60750
1-1/8"	HW602858	26mm	HW60260	51mm	HW60510	76mm	HW60760
1-3/16"	HW603016	27mm	HW60270	52mm	HW60520	77mm	HW60770
1-7/32"	HW603096	28mm	HW60280	53mm	HW60530	78mm	HW60780
1-1/4"	HW603175	29mm	HW60290	54mm	HW60540	79mm	HW60790
1-5/16"	HW603334	30mm	HW60300	55mm	HW60550	80mm	HW60800
1-3/8"	HW603493	31mm	HW60310	56mm	HW60560	85mm	HW60850
1-7/16"	HW603651	32mm	HW60320	57mm	HW60570	87mm	HW60870
1-1/2"	HW603810	33mm	HW60330	58mm	HW60580	90mm	HW60900
1-9/16"	HW603969	34mm	HW60340	59mm	HW60590	95mm	HW60950
1-5/8"	HW604128	35mm	HW60350	60mm	HW60600	100mm	HW61000
1-21/32"	HW604207	36mm	HW60360	61mm	HW60610	105mm	HW61050
1-11/16"	HW604286	37mm	HW60370	62mm	HW60620	108mm	HW61080
1-3/4"	HW604445	38mm	HW60380	63mm	HW60630	110mm	HW61100
1-13/16"	HW604604	39mm	HW60390	64mm	HW60640	115mm	HW61150
1-7/8"	HW604763	40mm	HW60400	65mm	HW60650	120mm	HW61200
1-15/16"	HW604921	41mm	HW60410	66mm	HW60660	130mm	HW61300
2"	HW605080	42mm	HW60420	67mm	HW60670	140mm	HW61400
2-1/16"	HW605239	43mm	HW60430	68mm	HW60680	150mm	HW61500
2-1/8"	HW605398	44mm	HW60440	69mm	HW60690	160mm	HW61600
2-3/16"	HW605556	45mm	HW60450	70mm	HW60700		
2-1/4"	HW605715	46mm	HW60460	71mm	HW60710		
2-5/16"	HW605874						
2-3/8"	HW606033						
2-7/16"	HW606191						
2-1/2"	HW606350						
2-9/16"	HW606509						
2-5/8"	HW606668						
2-3/4"	HW606985						
2-27/32	HW607223						
2-7/8"	HW607303						
3"	HW607620						
3-1/8"	HW607938						
3-1/4"	HW608255						
3-1/2"	HW608890						
3-3/4"	HW609522						
3-7/8"	HW609843						
4"	HW610160						
4-1/4"	HW610795						
5"	HW612700						
6"	HW615240						

ACCESSORY ARBOR PART NO.

φ22mm~φ44.9mm:1/2"-20 thread (from 7/8" ~ 1-3/4")	AB-HW05419D6
φ45 mm~φ160mm:5/8"-18 thread (from 1-7/8" ~ 6")	AB-HW07236D6

SPADE BIT PART NO.

φ22mm~φ160mm: 3/8"×114L (from 7/8"~6")	M-CD95114
---	-----------

ARBOR+BIT PART NO.

φ22mm~φ44.9mm:1/2"-20 thread (from 7/8" ~ 1-3/4")	AB-HW05419D6SB
φ45mm~φ160mm:5/8"-18 thread (from 1-7/8" ~ 6")	AB-HW07236D6SB

OPTIONAL CENTER DRILL



CENTER DRILL PART NO.

TCT	φ22 mm~φ160 mm: 120L (from 7/8" ~ 6")	M-CD86117ID
HSS	φ22 mm~φ160mm: 120L (from 7/8" ~ 6")	M-CD86117



HSS HOLE SAW

All features in comparison.



	SL	SF	SP	SG
Drilling depth	1.6mm	3mm	3mm	5mm
Effective length	12mm	12mm	28mm	28mm
Application Guide				
Metal Sheets SUS304	★★	★★	★★	★★
Metal Sheets SS41	★★★	★★★	★★★	★★★
Steel Pipes SUS304	★	★	★★★	★★★
Steel Pipes SS41	★	★	★★★	★★★
Cast Iron	★★★	★★★	★★★	★★★
Aluminum	★	★	★★	★★★
Copper	★	★	★★	★★★
Bronze	★	★	★★	★★★
I-Beam	★	★	★	★
Fiber Glass	★★★	★★★	★★★	★★★

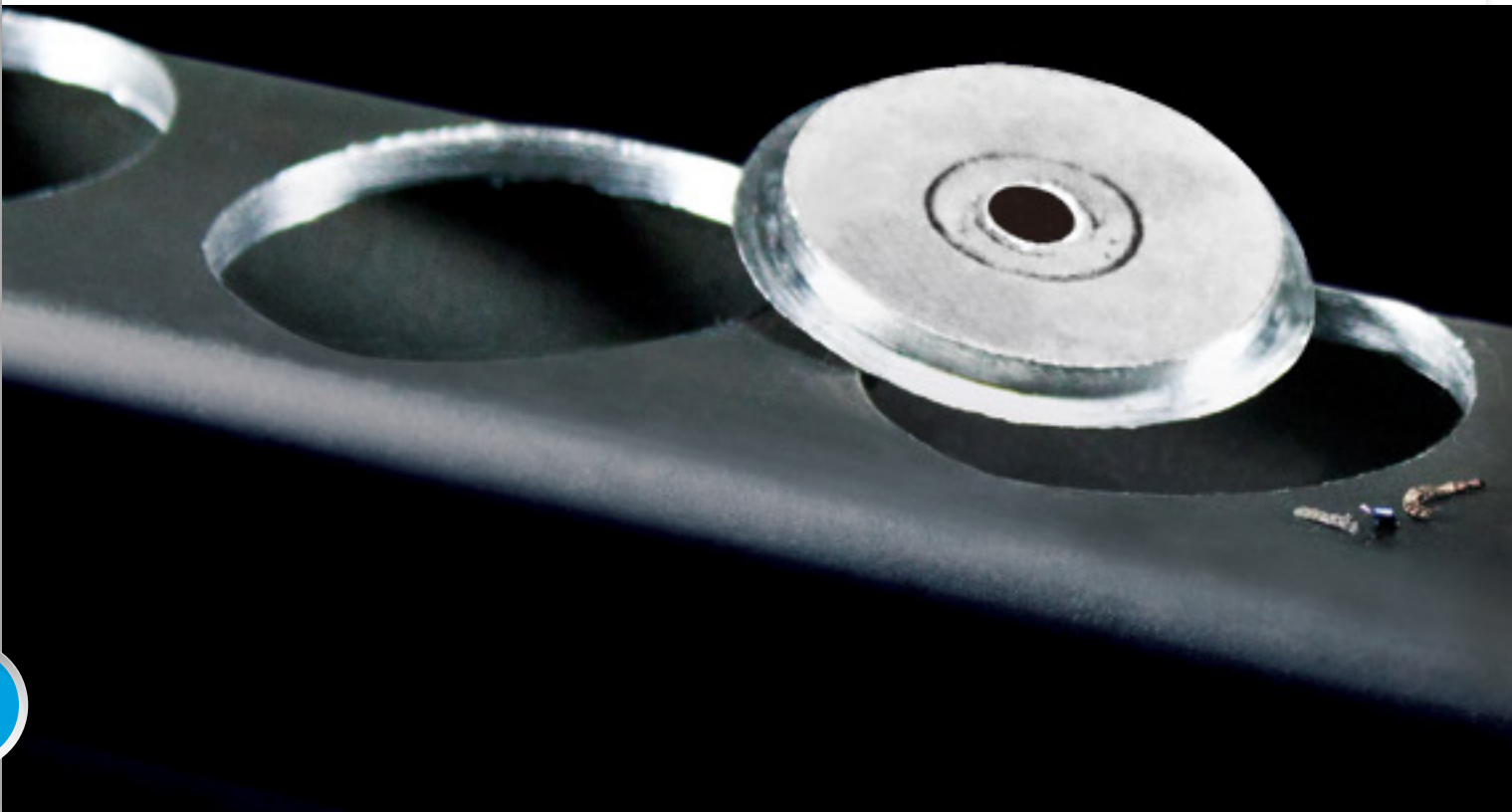



	SL	SF	SP	SG
Drilling depth	1.6mm	3mm	3mm	5mm
Effective length	12mm	12mm	28mm	28mm
Application Guide				
L-Bar	★	★	★★★	★★★
Concrete				
Masonry				
PVC Pipes	★★★	★★★	★★★	★★★
Railway				
Heat Treated Steel				
Square pipe	★★★	★★★	★★★	★★★
Stacked Steel				
Wood	★★★	★★★	★★★	★★★
Wood With Nails	★★★	★★★	★★★	★★★

★★★ : Excellent, ★★ : Good, ★ : Fair

HSS HOLE SAW / ALL FEATURES IN COMPARISON





SL TYPE

IDEAL FOR
METAL SHEET

FEATURES

- Material: M2
- Drilling depth: 1.6mm thick
- Effective length: 12mm deep

EXTRA LIGHT-CUT

Ø 12mm ~ Ø 150mm

APPLICATIONS

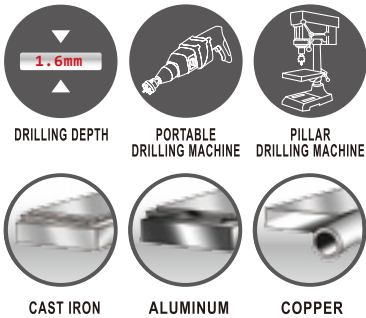

(See page 60 for more cutter's application)



IDEAL FOR DRILLING
UP TO 1.6MM METAL SHEET



PROPERTIES



- Center drill can lead the cutter to material as well as to cut safely and efficiently.
- High Speed Steel cutting edges for precision hole drilling.
- Faster and smoother cuts.
- Aggressive cutting action.
- Cutting Flange to prevent over drill.

ADVANTAGES

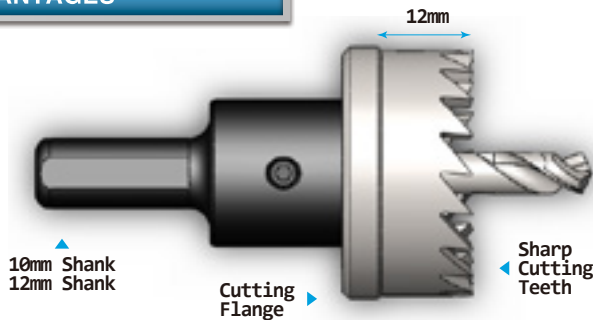

ACCESSORY ARBOR

PART NO.

φ12~φ24mm: 10mmshank	AB-HS05517D6
φ25~φ60mm: 10mm shank	AB-HS05521D6
φ61~φ100mm: 12mm shank	AB-HS05524D6
φ101~φ150mm: 12mm shank	AB-HS05531D8

CENTER DRILL

PART NO.

φ12mm~φ150mm: φ6mm×50L	M-CD60500
------------------------	-----------

DIA	ITEM NO.	DIA	ITEM NO.	DIA	ITEM NO.	DIA	ITEM NO.	DIA	ITEM NO.
12mm	SL20120	27mm	SL20270	42mm	SL20420	57mm	SL20560	75mm	SL20750
13mm	SL20130	28mm	SL20280	43mm	SL20430	58mm	SL20580	80mm	SL20800
14mm	SL20140	29mm	SL20290	44mm	SL20440	59mm	SL20590	85mm	SL20850
15mm	SL20150	30mm	SL20300	45mm	SL20450	60mm	SL20600	90mm	SL20900
16mm	SL20160	31mm	SL20310	46mm	SL20460	61mm	SL20610	95mm	SL20950
17mm	SL20170	32mm	SL20320	47mm	SL20470	62mm	SL20620	100mm	SL21000
18mm	SL20180	33mm	SL20330	48mm	SL20480	46mm	SL20460	105mm	SL21050
19mm	SL20190	34mm	SL20340	49mm	SL20490	63mm	SL20630	110mm	SL21100
20mm	SL20200	35mm	SL20350	50mm	SL20500	64mm	SL20640	115mm	SL21150
21mm	SL20210	36mm	SL20360	51mm	SL20510	65mm	SL20650	120mm	SL21200
22mm	SL20220	37mm	SL20370	52mm	SL20520	66mm	SL20660	125mm	SL21250
23mm	SL20230	38mm	SL20380	53mm	SL20530	67mm	SL20670	130mm	SL21300
24mm	SL20240	39mm	SL20390	54mm	SL20540	68mm	SL20680	135mm	SL21350
25mm	SL20250	40mm	SL20400	55mm	SL20550	69mm	SL20690	140mm	SL21400
26mm	SL20260	41mm	SL20410	56mm	SL20560	70mm	SL20700	145mm	SL21450
								150mm	SL21500

SF TYPE

IDEAL FOR
METAL SHEET



LIGHT-CUT

Ø 12mm ~ Ø 150mm

FEATURES

- Material: M2
- Drilling depth: 3mm thick
- Effective length: 12mm deep

APPLICATIONS

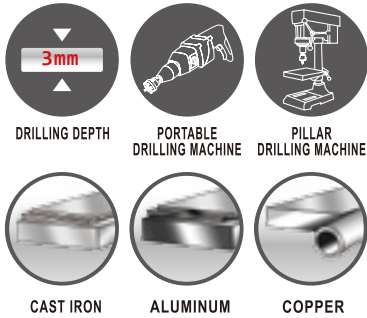

(See page 60 for more cutter's application)



IDEAL FOR DRILLING
UP TO 3MM METAL SHEET



PROPERTIES



- Center drill can lead the cutter to material as well as to cut safely and efficiently.
- High Speed Steel cutting edges for precision hole drilling.
- Faster and smoother cuts.
- Aggressive cutting action.
- Cutting Flange to prevent over drill.

ADVANTAGES

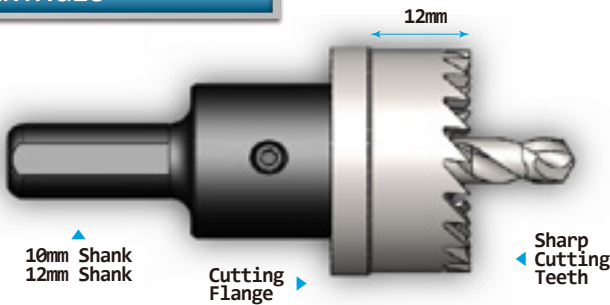

ACCESSORY ARBOR

PART NO.

φ12~φ24mm: 10mmshank	AB-HS05517D6
φ25~φ60mm: 10mm shank	AB-HS05521D6
φ61~φ100mm: 12mm shank	AB-HS05524D6
φ101~φ150mm: 12mm shank	AB-HS05531D8

CENTER DRILL

PART NO.

φ12mm~φ150mm: φ6mm×50L	M-CD60500
------------------------	-----------

DIA	ITEM NO.	DIA	ITEM NO.	DIA	ITEM NO.	DIA	ITEM NO.	DIA	ITEM NO.
12mm	SF50120	27mm	SF50270	42mm	SF50420	57mm	SF50570	80mm	SF50800
13mm	SF50130	28mm	SF50280	43mm	SF50430	58mm	SF50580	85mm	SF50850
14mm	SF50140	29mm	SF50290	44mm	SF50440	59mm	SF50590	90mm	SF50900
15mm	SF50150	30mm	SF50300	45mm	SF50450	60mm	SF50600	100mm	SF51000
16mm	SF50160	31mm	SF50310	46mm	SF50460	61mm	SF50610	105mm	SF51050
17mm	SF50170	32mm	SF50320	47mm	SF50470	62mm	SF50620	110mm	SF51100
18mm	SF50180	33mm	SF50330	48mm	SF50480	63mm	SF50630	115mm	SF51150
19mm	SF50190	34mm	SF50340	49mm	SF50490	64mm	SF50640	120mm	SF51200
20mm	SF50200	35mm	SF50350	50mm	SF50500	65mm	SF50650	125mm	SF51250
21mm	SF50210	36mm	SF50360	51mm	SF50510	66mm	SF50660	130mm	SF51300
22mm	SF50220	37mm	SF50370	52mm	SF50520	67mm	SF50670	135mm	SF51350
23mm	SF50230	38mm	SF50380	53mm	SF50530	68mm	SF50680	140mm	SF51400
24mm	SF50240	39mm	SF50390	54mm	SF50540	69mm	SF50690	145mm	SF51450
25mm	SF50250	40mm	SF50400	55mm	SF50550	70mm	SF50700	150mm	SF51500
26mm	SF50260	41mm	SF50410	56mm	SF50560	75mm	SF50750		



SP TYPE

IDEAL FOR
METAL SHEET

FEATURES

- Material: M2
- Drilling depth: 3mm thick
- Effective length: 28mm deep

LIGHT-CUT
Ø 15mm ~ Ø 100mm

APPLICATIONS

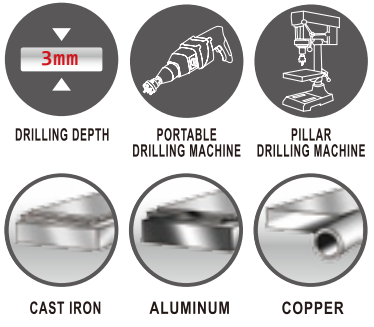

(See page 60 for more cutter's application)



IDEAL FOR DRILLING UP TO 3MM METAL SHEET



PROPERTIES



- Center drill can lead the cutter to material as well as to cut safely and efficiently.



- The slug is ejected by spring when cutting is finished.



- High Speed Steel cutting edges for precision hole drilling.
- Faster and smoother cuts.
- Heavy-duty cutting program solution.

ADVANTAGES

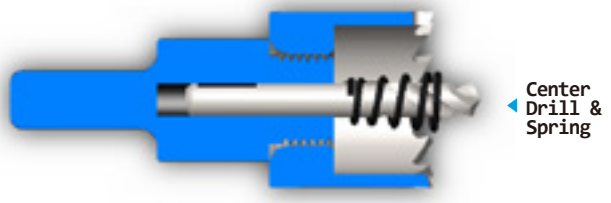
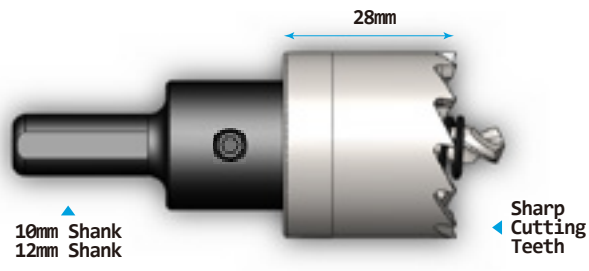

DIA	ITEM NO.	DIA	ITEM NO.	DIA	ITEM NO.	DIA	ITEM NO.
15mm	SP80150	31mm	SP80310	47mm	SP80470	63mm	SP80630
16mm	SP80160	32mm	SP80320	48mm	SP80480	64mm	SP80640
17mm	SP80170	33mm	SP80330	49mm	SP80490	65mm	SP80650
18mm	SP80180	34mm	SP80340	50mm	SP80500	66mm	SP80660
19mm	SP80190	35mm	SP80350	51mm	SP80510	67mm	SP80670
20mm	SP80200	36mm	SP80360	52mm	SP80520	68mm	SP80680
21mm	SP80210	37mm	SP80370	53mm	SP80530	69mm	SP80690
22mm	SP80220	38mm	SP80380	54mm	SP80540	70mm	SP80700
23mm	SP80230	39mm	SP80390	55mm	SP80550	75mm	SP80750
24mm	SP80240	40mm	SP80400	56mm	SP80560	80mm	SP80800
25mm	SP80250	41mm	SP80410	57mm	SP80570	85mm	SP80850
26mm	SP80260	42mm	SP80420	58mm	SP80580	90mm	SP80900
27mm	SP80270	43mm	SP80430	59mm	SP80590	95mm	SP80950
28mm	SP80280	44mm	SP80440	60mm	SP80600	100mm	SP81000
29mm	SP80290	45mm	SP80450	61mm	SP80610		
30mm	SP80300	46mm	SP80460	62mm	SP80620		

ACCESSORY ARBOR	ITEM NO.
φ15~φ24mm: 10mm shank	AB-HS05521D6
φ25~φ60mm: 10mm shank	AB-HS05521D6
φ61~φ100mm: 12mm shank	AB-HS05524D6

CENTER DRILL	ITEM NO.
φ15mm~φ100mm: φ6mm×60L	M-CD60600S

SPRING	ITEM NO.
φ15mm~φ100mm	M-SP6060BB

SG TYPE

IDEAL FOR
METAL SHEET

FEATURES

- Material: M2
- Drilling depth: 5mm thick
- Effective length: 28mm deep

APPLICATIONS

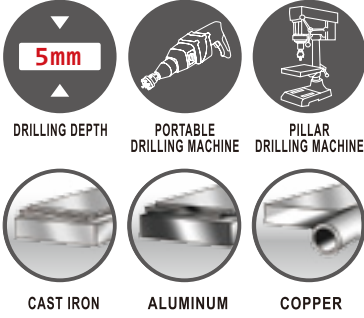

(See page 60 for more cutter's application)



IDEAL FOR DRILLING
UP TO 5MM METAL SHEET

LIGHT-CUT
Ø 15mm ~ Ø 100mm



PROPERTIES



- Center drill can lead the cutter to material as well as to cut safely and efficiently.



- The slug is ejected by spring when cutting is finished.



- High Speed Steel cutting edges for precision hole drilling.
- Faster and smoother cuts.
- Heavy-duty cutting program solution.

ADVANTAGES

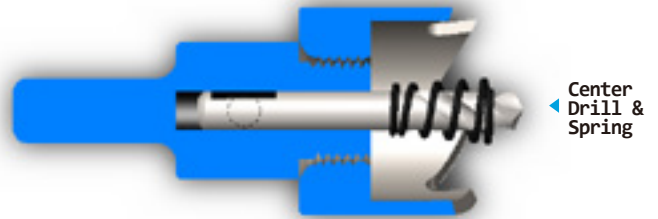
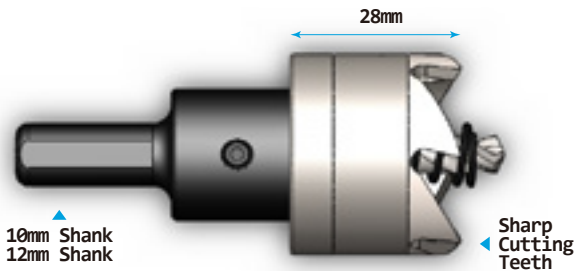

Center Drill & Spring

DIA	ITEM NO.	DIA	ITEM NO.	DIA	ITEM NO.	DIA	ITEM NO.	ACCESSORY ARBOR	ITEM NO.
15mm	SG60150	31mm	SG60310	47mm	SG60470	63mm	SG60630	φ15~φ24mm: 10mm shank	AB-HS05521D6
16mm	SG60160	32mm	SG60320	48mm	SG60480	64mm	SG60640	φ25~φ60mm: 10mm shank	AB-HS05521D6
17mm	SG60170	33mm	SG60330	49mm	SG60490	65mm	SG60650	φ61~φ100mm: 12mm shank	AB-HS05524D6
18mm	SG60180	34mm	SG60340	50mm	SG60500	66mm	SG60660		
19mm	SG60190	35mm	SG60350	51mm	SG60510	67mm	SG60670		
20mm	SG60200	36mm	SG60360	52mm	SG60520	68mm	SG60680		
21mm	SG60210	37mm	SG60370	53mm	SG60530	69mm	SG60690		
22mm	SG60220	38mm	SG60380	54mm	SG60540	70mm	SG60700		
23mm	SG60230	39mm	SG60390	55mm	SG60550	75mm	SG60750		
24mm	SG60240	40mm	SG60400	56mm	SG60560	80mm	SG60800		
25mm	SG60250	41mm	SG60410	57mm	SG60570	85mm	SG60850		
26mm	SG60260	42mm	SG60420	58mm	SG60580	90mm	SG60900		
27mm	SG60270	43mm	SG60430	59mm	SG60590	95mm	SG60950		
28mm	SG60280	44mm	SG60440	60mm	SG60600	100mm	SG61000		
29mm	SG60290	45mm	SG60450	61mm	SG60610				
30mm	SG60300	46mm	SG60460	62mm	SG60620				

CENTER DRILL		ITEM NO.
φ15mm~φ100mm: φ6mm×60L		M-CD60600S



SPRING		ITEM NO.
φ15mm~φ100mm		M-SP6060BB



SHAJENG HARDWARE CO., LTD

Application Guide



	Drilling depth	Effective length	Metal Sheets SUS304	Metal Sheets SS41	Steel Pipes SUS304	Steel Pipes SS41	Cast Iron	Aluminum	Copper	Bronze	I-Beam	Fiber Glass
 HT	45 mm	65 mm										
 HD	95 mm	125 mm										
 HB	80 mm	100 mm										



CORE DRILL / ALL FEATURES IN COMPARISON

	Drilling depth	Effective length	Application Guide												
			L-Bar	Concrete	Masonry	PVC Pipes	Railway	Heat Treated Steel	Square pipe	Stacked Steel	Wood	Wood With Nails			
HT	45 mm	65 mm		★★	★★										
HD	95 mm	125 mm		★★★	★★★										
HB	80 mm	100 mm		★★★	★★★										

★★★ : Excellent, ★★ : Good, ★ : Fair

45mm

HT TYPE

SHAJENG HARDWARE CO., LTD

HT TYPE

IDEAL FOR
CONCRETE BORING

FEATURES

- Material: Tungsten Carbide Tipped
- Drilling depth: 45mm thick
- Effective length: 65mm deep

Economical Type TCT Hole Saw

HEAVY-DUTY
Ø 25mm ~ Ø 125mm

APPLICATIONS

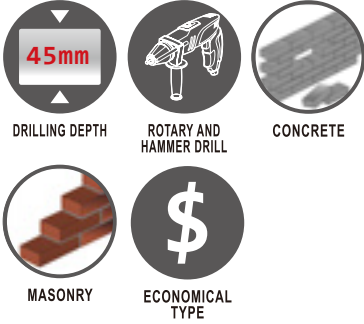

(See page 66 for more cutter's application)

PROPERTIES



- Center drill can lead the cutter to material as well as to prevent carbide damage.

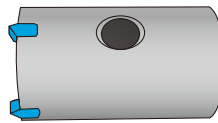

IDEAL FOR DRILLING
CONCRETE / MASONRY

- With its extremely sharp Tungsten Carbide Tipped cutting edges, it can be run at higher feed rate and speed to create holes of exceptional precision and cleanliness.

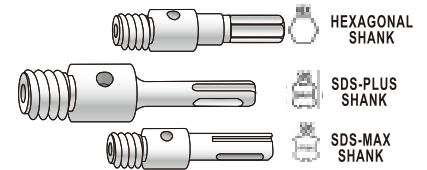

- Exchangeable arbor and center drill.
- 3 arbor shanks to fit different types of machines.



Features

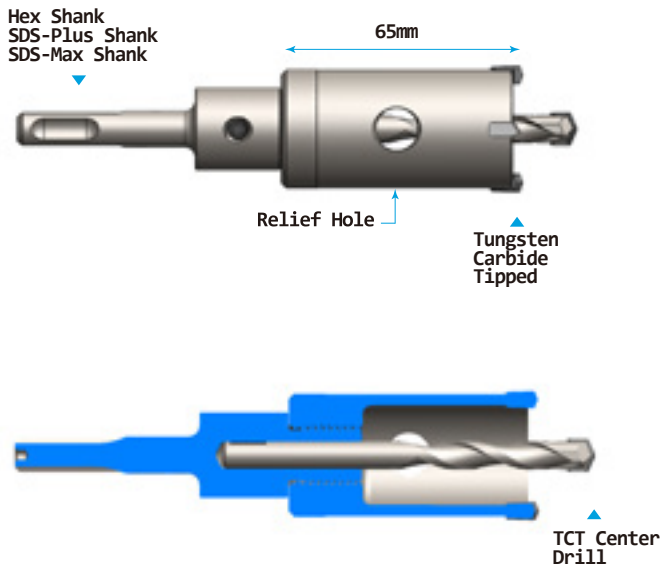

Using Guide

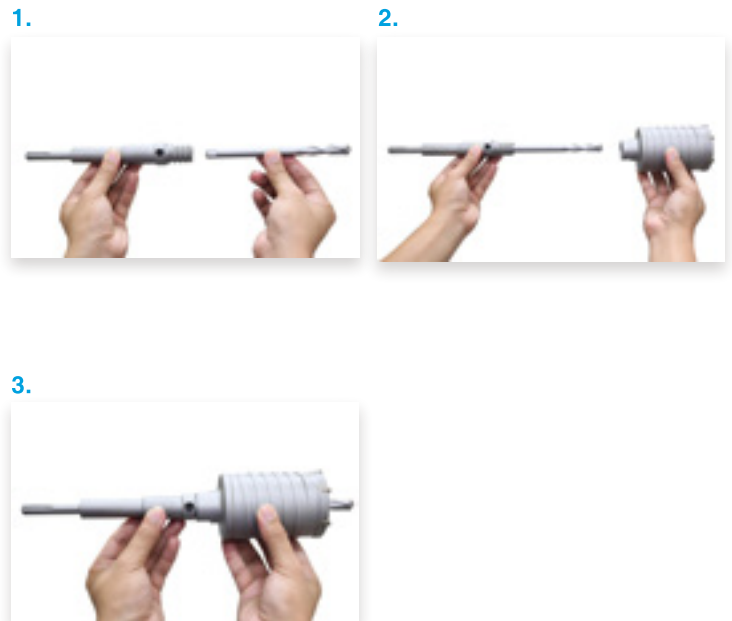

ACCESSORY

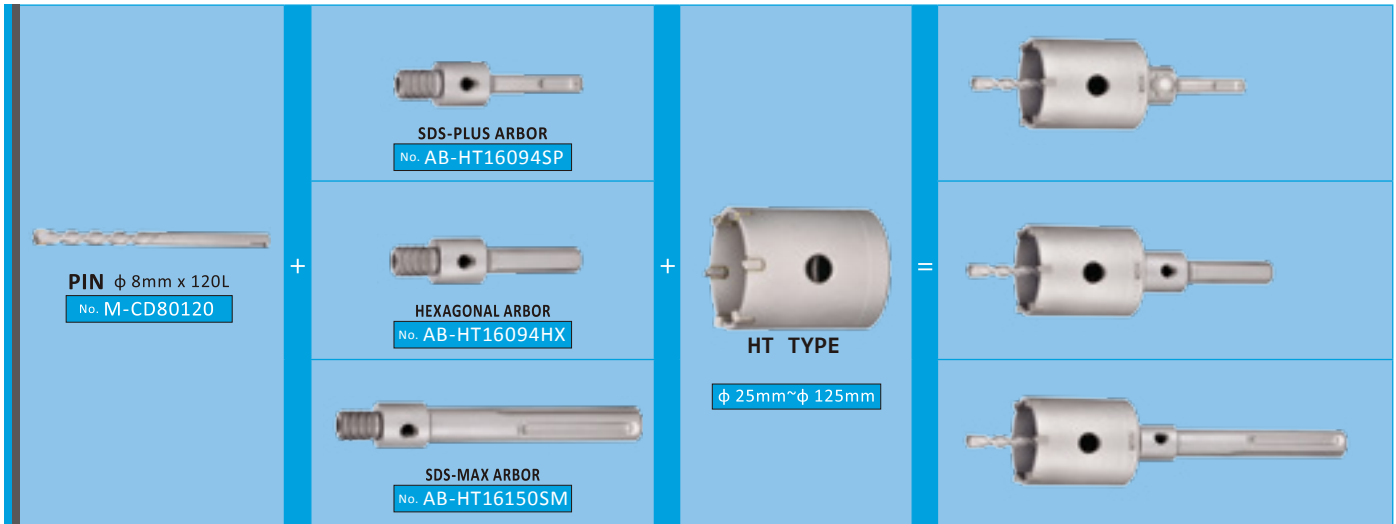

ACCESSORY ARBOR	PART NO.
SDS-Plus arbor 94L	AB-HT16094SP
Hexagonal arbor 94L	AB-HT16094HX
SDS-Max arbor 150L	AB-HT16150SM

CENTER DRILL	PART NO.
φ25mm~φ125mm: φ8mm×120L	M-CD80120

DIA.	ITEM NO.	Core Bit Complete With Center Drill And Hexagonal Shank	Core Bit Complete With Center Drill And SDS-Plus-Plus Shank	Core Bit Complete With Center Drill And SDS-Max Shank
		ITEM NO.	ITEM NO.	ITEM NO.
25mm	HT50250	HT50250H	HT50250SP	HT50250SM
30mm	HT50300	HT50300H	HT50300SP	HT50300SM
32mm	HT50320	HT50320H	HT50320SP	HT50320SM
33mm	HT50330	HT50330H	HT50330SP	HT50330SM
35mm	HT50350	HT50350H	HT50350SP	HT50350SM
40mm	HT50400	HT50400H	HT50400SP	HT50400SM
45mm	HT50450	HT50450H	HT50450SP	HT50450SM
50mm	HT50500	HT50500H	HT50500SP	HT50500SM
55mm	HT50550	HT50550H	HT50550SP	HT50550SM
60mm	HT50600	HT50600H	HT50600SP	HT50600SM
65mm	HT50650	HT50650H	HT50650SP	HT50650SM
66mm	HT50660	HT50660H	HT50660SP	HT50660SM
68mm	HT50680	HT50680H	HT50680SP	HT50680SM
70mm	HT50700	HT50700H	HT50700SP	HT50700SM
72mm	HT50720	HT50720H	HT50720SP	HT50720SM
75mm	HT50750	HT50750H	HT50750SP	HT50750SM
80mm	HT50800	HT50800H	HT50800SP	HT50800SM
82mm	HT50820	HT50820H	HT50820SP	HT50820SM
85mm	HT50850	HT50850H	HT50850SP	HT50850SM
90mm	HT50900	HT50900H	HT50900SP	HT50900SM
100mm	HT51000	HT51000H	HT51000SP	HT51000SM
125mm	HT51250	HT51250H	HT51250SP	HT51250SM



95mm

HD TYPE

SHAJENG HARDWARE CO., LTD

HD TYPE

IDEAL FOR
CONCRETE BORING

FEATURES

- Material: Tungsten Carbide Tipped
- Drilling depth: 95mm thick
- Effective length: 125mm deep

HEAVY-DUTY
Ø 25mm ~ Ø 200mm

APPLICATIONS



DRILLING DEPTH



ROTARY AND
HAMMER DRILL



CONCRETE

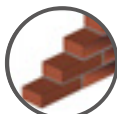

MASONRY

(See page 66 for more cutter's application)

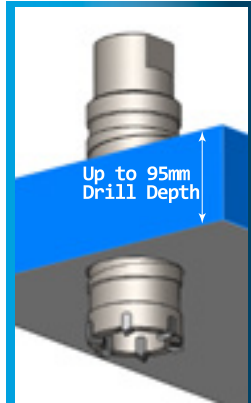

IDEAL FOR DRILLING
CONCRETE / MASONRY



PROPERTIES



- Center drill can lead the cutter to material as well as to prevent carbide damage.

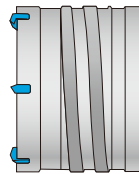

- With its extremely sharp Tungsten Tipped cutting edges, it can be run at higher feed rate and speed to create holes of exceptional precision and cleanliness.

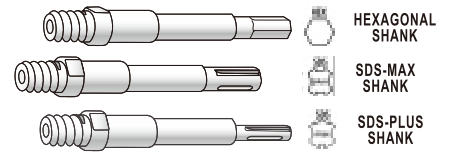

- Exchangeable arbor and center drill.
- 3 arbor shanks to fit different types of machines.

Features

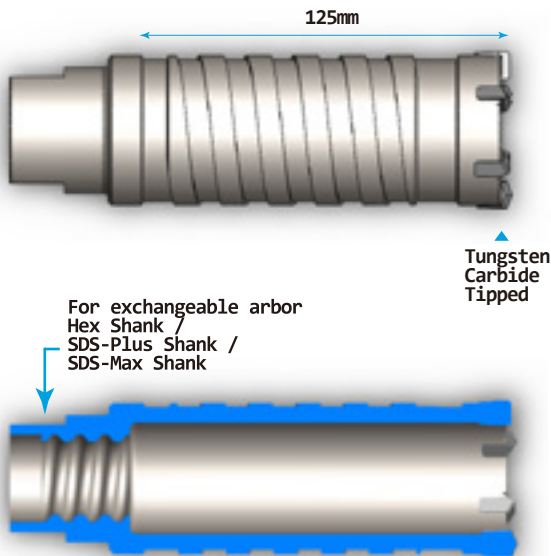

Using Guide

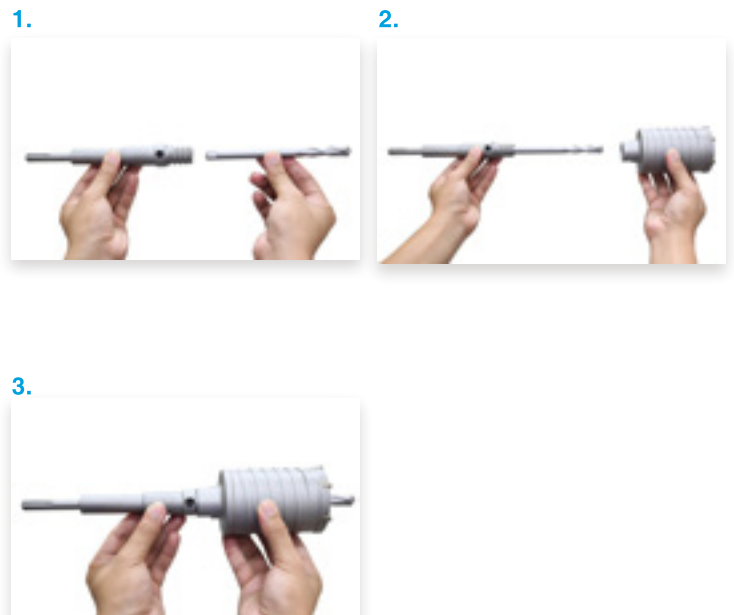

ACCESSORY

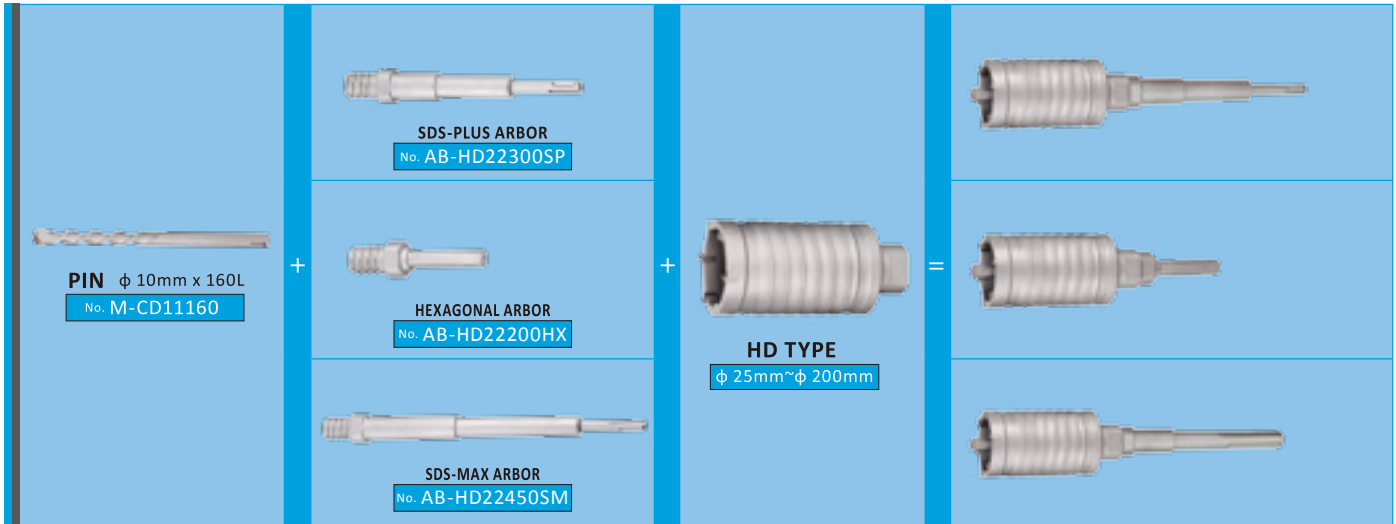

CORE DRILL / HD TYPE

ACCESSORY ARBOR	PART NO.
22MA Hexagonal arbor 200L	AB-HD22200HX
22MA Hexagonal arbor 450L	AB-HD22450HX
22MA SDS-Plus arbor 105L	AB-HD22105SP
22MA SDS-Plus arbor 200L	AB-HD22200SP
22MA SDS-Plus arbor 300L	AB-HD22300SP
22MA SDS-Plus arbor 450L	AB-HD22450SP
22MA SDS-Max arbor 105L	AB-HD22105SM
22MA SDS-Max arbor 200L	AB-HD22200SM
22MA SDS-Max arbor 300L	AB-HD22300SM
22MA SDS-Max arbor 450L	AB-HD22450SM

CENTER DRILL	PART NO.
φ25mm~φ200mm: φ10mm×160L	M-CD11160



DIA.	ITEM NO.	ITEM NO.	ITEM NO.	ITEM NO.
25mm	HD10250	HD10250H	HD10250SP	HD10250SM
29mm	HD10290	HD10290H	HD10290SP	HD10290SM
30mm	HD10300	HD10300H	HD10300SP	HD10300SM
32mm	HD10320	HD10320H	HD10320SP	HD10320SM
35mm	HD10350	HD10350H	HD10350SP	HD10350SM
38mm	HD10380	HD10380H	HD10380SP	HD10380SM
40mm	HD10400	HD10400H	HD10400SP	HD10400SM
45mm	HD10450	HD10450H	HD10450SP	HD10450SM
48mm	HD10480	HD10480H	HD10480SP	HD10480SM
50mm	HD10500	HD10500H	HD10500SP	HD10500SM
55mm	HD10550	HD10550H	HD10550SP	HD10550SM
60mm	HD10600	HD10600H	HD10600SP	HD10600SM
65mm	HD10650	HD10650H	HD10650SP	HD10650SM
66mm	HD10660	HD10660H	HD10660SP	HD10660SM
68mm	HD10680	HD10680H	HD10680SP	HD10680SM
70mm	HD10700	HD10700H	HD10700SP	HD10700SM
75mm	HD10750	HD10750H	HD10750SP	HD10750SM
76mm	HD10760	HD10760H	HD10760SP	HD10760SM
80mm	HD10800	HD10800H	HD10800SP	HD10800SM
85mm	HD10850	HD10850H	HD10850SP	HD10850SM
90mm	HD10900	HD10900H	HD10900SP	HD10900SM
95mm	HD10950	HD10950H	HD10950SP	HD10950SM
100mm	HD11000	HD11000H	HD11000SP	HD11000SM
105mm	HD11050	HD11050H	HD11050SP	HD11050SM
110mm	HD11100	HD11100H	HD11100SP	HD11100SM
115mm	HD11150	HD11150H	HD11150SP	HD11150SM
120mm	HD11200	HD11200H	HD11200SP	HD11200SM
125mm	HD11250	HD11250H	HD11250SP	HD11250SM
130mm	HD11300	HD11300H	HD11300SP	HD11300SM
150mm	HD11500	HD11500H	HD11500SP	HD11500SM
160mm	HD11600	HD11600H	HD11600SP	HD11600SM
170mm	HD11700	HD11700H	HD11700SP	HD11700SM
180mm	HD11800	HD11800H	HD11800SP	HD11800SM
200mm	HD12000	HD12000H	HD12000SP	HD12000SM

80mm

HB TYPE

SHAJENG HARDWARE CO., LTD

HB TYPE

IDEAL FOR
CONCRETE BORING



HEAVY-DUTY
Ø 25mm ~ Ø 200mm

FEATURES

- Material: Tungsten Carbide Tipped
- Drilling depth: 80mm thick
- Effective length: 100mm deep

APPLICATIONS

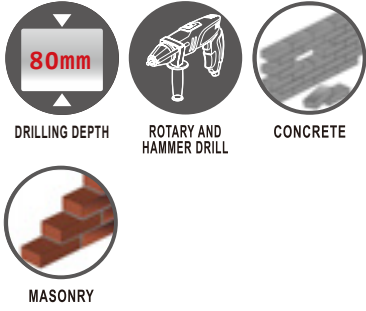

(See page 66 for more cutter's application)

PROPERTIES



- Center drill can lead the cutter to material as well as to prevent carbide damage.

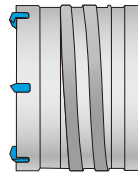
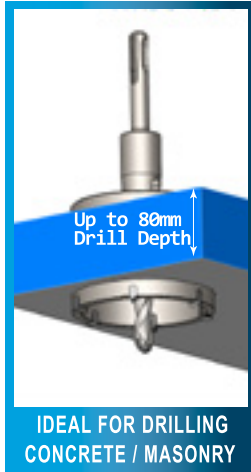

- With its extremely sharp Tungsten Carbide Tipped cutting edges, it can be run at higher feed rate and speed to create holes of exceptional precision and cleanliness.



DRIFT KEY

Made to easily remove the shank from the core bit.

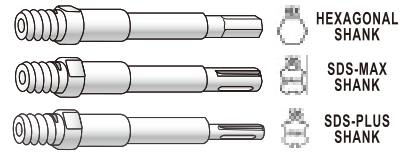

- Exchangeable arbor and center drill.
- 3 arbor shanks to fit different types of machines.

Features

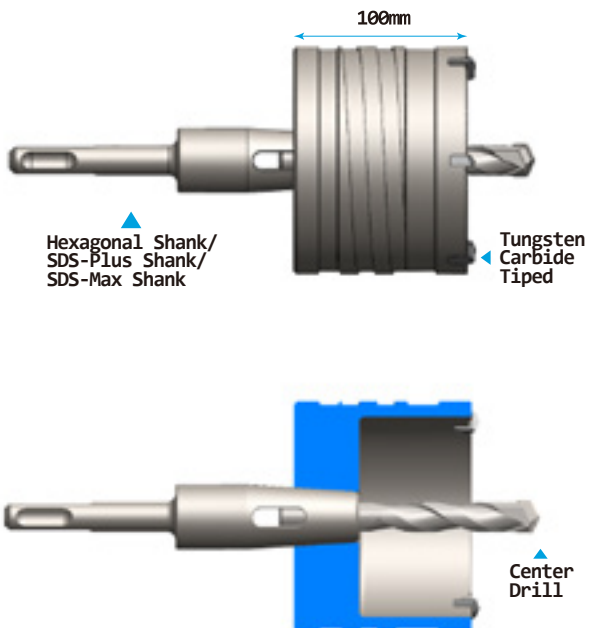

Using Guide

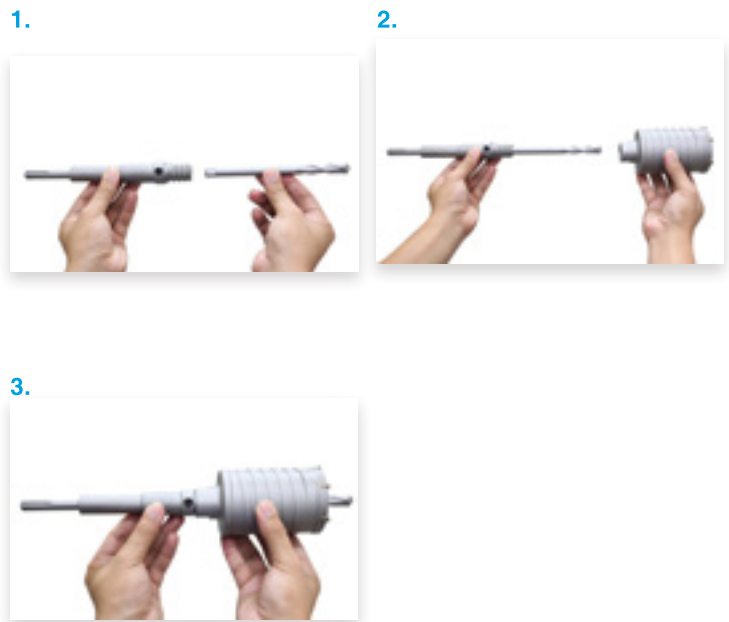

ACCESSORY

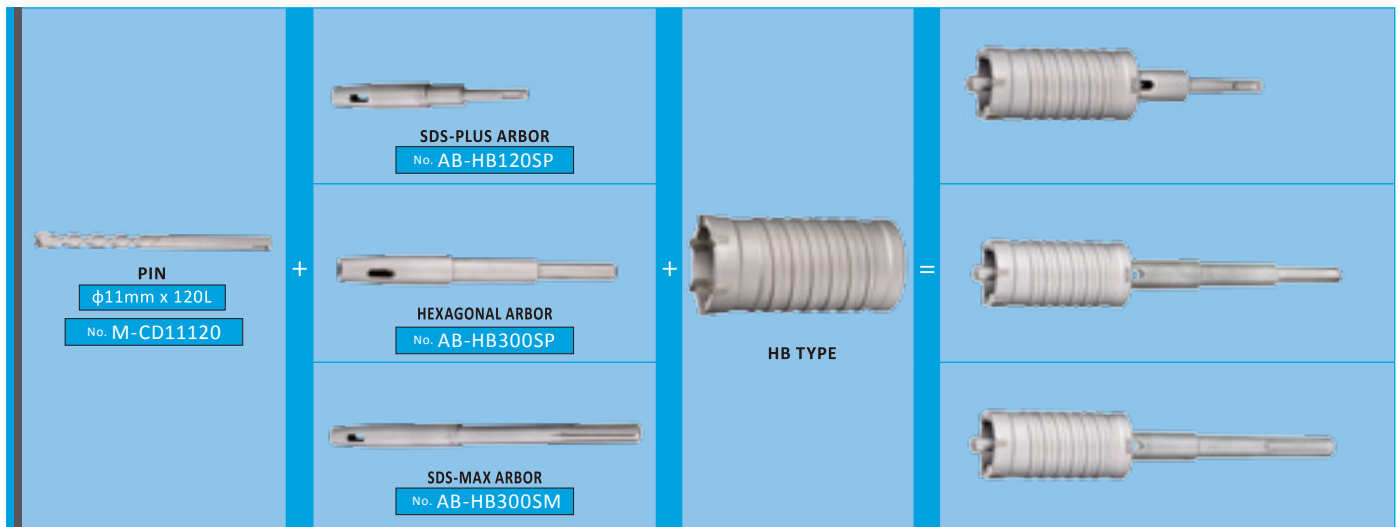

CORE DRILL / HB TYPE

ACCESSORY ARBOR	PART NO.
Hexagonal arbor 120L	AB-HB120HX
Hexagonal arbor 180L	AB-HB180HX
Hexagonal arbor 300L	AB-HB300HX
Hexagonal arbor 450L	AB-HB450HX
SDS-Plus arbor 120L	AB-HB120SP
SDS-Plus arbor 180L	AB-HB180SP
SDS-Plus arbor 300L	AB-HB300SP
SDS-Plus arbor 450L	AB-HB450SP
SDS-Max arbor 180L	AB-HB180SM
SDS-Max arbor 300L	AB-HB300SM
SDS-Max arbor 450L	AB-HB450SM

CENTER DRILL	PART NO.
φ25mm~φ200mm: φ11mm×120L	M-CD11120

Drift Key	PART NO.
135L	M-10135DK

	M-10135DK
	AB-HB180SP
	AB-HB120SP
	M-CD11120
	AB-HB300HX
	AB-HB450SM

DIA.	ITEM NO.	ITEM NO.	ITEM NO.	ITEM NO.
25mm	HB10250	HB10250H	HB10250SP	HB10250SM
29mm	HB10290	HB10290H	HB10290SP	HB10290SM
30mm	HB10300	HB10300H	HB10300SP	HB10300SM
32mm	HB10320	HB10320H	HB10320SP	HB10320SM
35mm	HB10350	HB10350H	HB10350SP	HB10350SM
38mm	HB10380	HB10380H	HB10380SP	HB10380SM
40mm	HB10400	HB10400H	HB10400SP	HB10400SM
45mm	HB10450	HB10450H	HB10450SP	HB10450SM
50mm	HB10500	HB10500H	HB10500SP	HB10500SM
55mm	HB10550	HB10550H	HB10550SP	HB10550SM
60mm	HB10600	HB10600H	HB10600SP	HB10600SM
65mm	HB10650	HB10650H	HB10650SP	HB10650SM
66mm	HB10660	HB10660H	HB10660SP	HB10660SM
68mm	HB10680	HB10680H	HB10680SP	HB10680SM
70mm	HB10700	HB10700H	HB10700SP	HB10700SM
73mm	HB10730	HB10730H	HB10730SP	HB10730SM
75mm	HB10750	HB10750H	HB10750SP	HB10750SM
76mm	HB10760	HB10760H	HB10760SP	HB10760SM
80mm	HB10800	HB10800H	HB10800SP	HB10800SM
83mm	HB10830	HB10830H	HB10830SP	HB10830SM
85mm	HB10850	HB10850H	HB10850SP	HB10850SM
90mm	HB10900	HB10900H	HB10900SP	HB10900SM
95mm	HB10950	HB10950H	HB10950SP	HB10950SM
100mm	HB11000	HB11000H	HB11000SP	HB11000SM
105mm	HB11050	HB11050H	HB11050SP	HB11050SM
110mm	HB11100	HB11100H	HB11100SP	HB11100SM
115mm	HB11150	HB11150H	HB11150SP	HB11150SM
120mm	HB11200	HB11200H	HB11200SP	HB11200SM
125mm	HB11250	HB11250H	HB11250SP	HB11250SM
130mm	HB11300	HB11300H	HB11300SP	HB11300SM
150mm	HB11500	HB11500H	HB11500SP	HB11500SM
160mm	HB11600	HB11600H	HB11600SP	HB11600SM
170mm	HB11700	HB11700H	HB11700SP	HB11700SM
180mm	HB11800	HB11800H	HB11800SP	HB11800SM
200mm	HB12000	HB12000H	HB12000SP	HB12000SM



TCT HOLE CUTTER

All features in comparison.



	HC Standard	HC Tin	HC50S	HCD Series	HCL Series	HCR Series
APPLICATION	HC25, HC35, HC50, HC75, HC110	HC25, HC35, HC50, HC75, HC110	HC50S	HCD35, HCD50, HCD75, HCD110	HCL50F, HCL75, HCL110	2HCR25, 2HCR35, 2HCR50

Application Guide

	Metal Sheets SUS304	★★	★★	★★	★★	★★	★★★
	Metal Sheets SS41	★★★	★★★	★★★	★★★	★★★	★★★
	Steel Pipes SUS304	★★	★★	★★★	★★	★★	★★★
	Steel Pipes SS41	★★	★★	★★★	★★★	★★★	★★★
	Cast Iron	★★★	★★★	★★★	★★★	★★★	★★★
	Aluminum	★★	★★	★★	★	★★	★★★
	Copper	★★	★★	★★	★	★★	★★★
	Bronze	★★	★★	★★	★	★★	★★★
	I-Beam	★★★	★★★	★★★	★★★	★★★	★★★
	Fiber Glass						



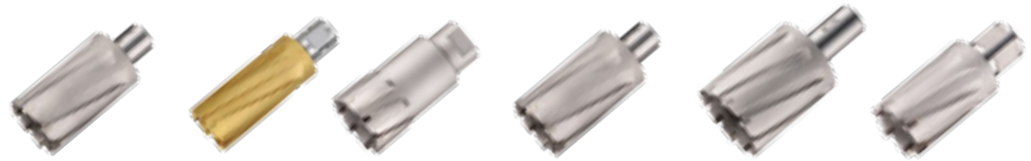

	HC Sstandard	HC Tin	HC50S	HCD Series	HCL Series	HCR Series
APPLICATION	HC25, HC35, HC50, HC75, HC110	HC25, HC35, HC50, HC75, HC110	HC50S	HCD35 HCD50 HCD75 HCD110	HCL50F HCL75 HCL110	2HCR25 2HCR35 2HCR50

Application Guide

L-Bar	★★★	★★★	★★★	★★★	★★★	★★★
Concrete						
Masonry						
PVC Pipes						
Railway	★	★	★	★	★	★★★
Heat Treated Steel	★	★	★	★	★	★★★
Square pipe	★★★	★★★	★★★	★★★	★★★	★★★
Stacked Steel				★★★		
Wood						
Wood With Nails						

★★★ : Excellent, ★★ : Good, ★ : Fair





HC STANDARD SERIES

- Material: Tungsten Carbide Micro Grade
- Drilling depth: 25mm, 35mm, 50mm, 75mm, 110mm
- Effective length: 40mm, 50mm, 70mm, 90mm, 120mm
- Special designed cutting edges.
- The special tooth arrangement makes cutting smooth.
- Can be run at higher speeds and higher feed rates.
- Can bore steel and for heavy-duty works.



HEAVY-DUTY
Ø 12mm ~ Ø 70mm

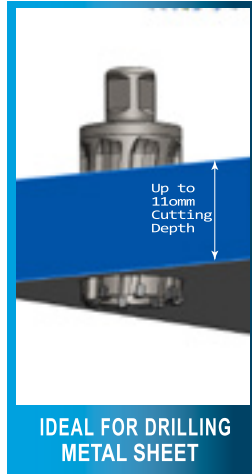



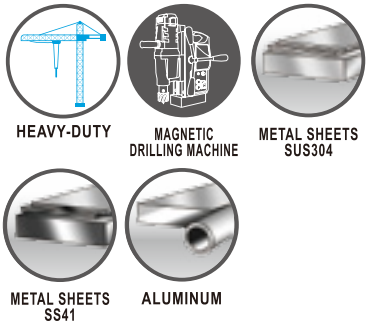





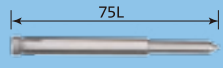

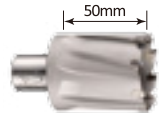
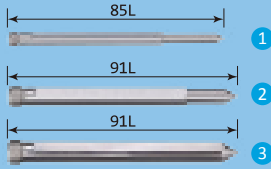
APPLICATIONS

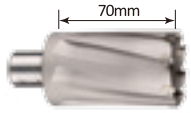

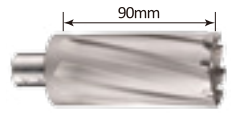
(See page 74 for more cutter's application)

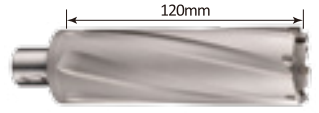
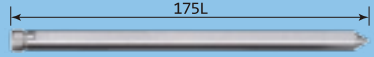
SHAJENG HARDWARE CO., LTD

TYPE	PIN	
<p>HC25</p>  <p>ITEM NO. φ14mm~40mm / φ1/2"~1-1/2"</p>	<p>75L</p>  <p>SHC30675P φ6.34mm×4.8mm×75L</p>	<p>HC25</p> 
<p>HC35</p>  <p>ITEM NO. φ12mm~13mm / φ1/2" φ14mm~15mm / φ9/16" φ16mm~52mm / φ5/8"~2-7/16"</p>	<p>85L, 91L, 91L</p>  <p>1 HC35485P φ4.75mm×3.6mm×85L 2 HC35791P φ7.1mm x 5.8mm x 91L 3 HC35891P φ8.0mm×91L</p>	<p>HC35</p> 
<p>HC50</p>  <p>ITEM NO. φ12mm~13mm / φ1/2" φ14mm~17mm / φ9/16"~5/8" φ17.5mm~70mm / φ11/16"~2-1/2"</p>	<p>100L, 112L, 112L</p>  <p>1 SHC554100P φ4.74mm×3.6mm×100L 2 HC506112P φ6.34mm x112L 3 HC508112P φ8.0mm×112L</p>	<p>HC50</p> 
<p>HC75</p>  <p>ITEM NO. φ16mm~70mm / φ3/4"~3"</p>	<p>138L</p>  <p>HC758138P φ8.0mm×138L</p>	<p>HC75</p> 
<p>HC110</p>  <p>ITEM NO. φ18mm~70mm / φ7/8"~2-1/4"</p>	<p>175L</p>  <p>HC1108175P φ8.0mm×175L</p>	<p>HC110</p> 

ADAPTER		TYPE			
FEIN Quick-In 18mm WELDON 19mm 3/4" AD32100F					
HITACHI /THREAD WELDON 19mm 3/4" AD32200H					
NITTO 19mm WELDON 19mm 3/4" AD32300N	+		+		
ALFRA 19mm WELDON 19mm 3/4" AD32400A					
WELDON 19mm NITTO 19mm 3/4" AD32500W	+		+		

EXTENSIONS		TYPE	
 WELDON 19mm 3/4" WELDON 19mm 3/4" ED10500 50L	+		▲ WELDON SHANK
 WELDON 19mm 3/4" WELDON 19mm 3/4" ED10750 75L	+		▲ WELDON SHANK
 WELDON 19mm 3/4" WELDON 19mm 3/4" ED101000 100L	+		▲ WELDON SHANK
 WELDON 19mm 3/4" WELDON 19mm 3/4" ED101500 150L	+		▲ WELDON SHANK



T.C.T. CUTTER
Can afford heavy-duty drills.

Entirely Fluted
Provides better chip clearance and offers higher cutting performance.

Tungsten Carbide Tipped Cutting Edges

It can be run at higher feed rate and speed to create holes of exceptional precision and cleanliness.

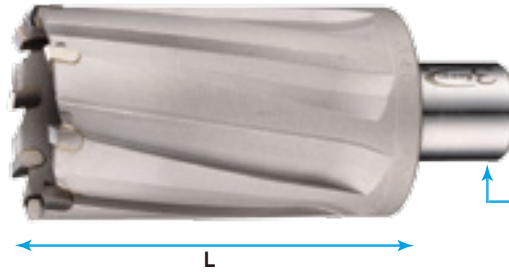

Shank
Different shank types to meet customer's demand.

DIAMETER	HC25 TYPE	HC35 TYPE	HC50 TYPE	HC75 TYPE	HC110 TYPE
Drilling depth	25mm	35mm	50mm	75mm	110mm
Effective length	40mm	50mm	70mm	90mm	120mm
Shank diameter	φ19.05mm	φ19.05mm	φ19.05mm (below 70mm) φ31.75mm X 34L (above 71mm)	φ19.05mm	φ19.05mm

DIA.	ITEM NO.	ITEM NO.	ITEM NO.	ITEM NO.	ITEM NO.
12mm	—	HC35120	HC50120	—	—
13mm	—	HC35130	HC50130	—	—
14mm	HC25140	HC35140	HC50140	—	—
15mm	HC25150	HC35150	HC50150	—	—
16mm	HC25160	HC35160	HC50160	HC75160	—
17mm	HC25170	HC35170	HC50170	HC75170	—
17.5mm	—	HC35175	HC50175	—	—
18mm	HC25180	HC35180	HC50180	HC75180	HC110180
19mm	HC25190	HC35190	HC50190	HC75190	HC110190
20mm	HC25200	HC35200	HC50200	HC75200	HC110200
21mm	HC25210	HC35210	HC50210	HC75210	HC110210
22mm	HC25220	HC35220	HC50220	HC75220	HC110220
22.5mm	—	HC35225	—	—	—
23mm	HC25230	HC35230	HC50230	HC75230	HC110230
23.5mm	—	HC35235	—	—	—
24mm	HC25240	HC35240	HC50240	HC75240	HC110240
24.5mm	—	HC35245	HC50245	—	—
25mm	HC25250	HC35250	HC50250	HC75250	HC110250
25.5mm	—	HC35255	—	—	—
26mm	HC25260	HC35260	HC50260	HC75260	HC110260
26.5mm	—	HC35265	HC50265	—	—
27mm	HC25270	HC35270	HC50270	HC75270	HC110270
28mm	HC25280	HC35280	HC50280	HC75280	HC110280
29mm	HC25290	HC35290	HC50290	HC75290	HC110290
30mm	HC25300	HC35300	HC50300	HC75300	HC110300
31mm	HC25310	HC35310	HC50310	HC75310	HC110310
32mm	HC25320	HC35320	HC50320	HC75320	HC110320
33mm	HC25330	HC35330	HC50330	HC75330	HC110330
34mm	HC25340	HC35340	HC50340	HC75340	HC110340
35mm	HC25350	HC35350	HC50350	HC75350	HC110350
36mm	HC25360	HC35360	HC50360	HC75360	HC110360
37mm	HC25370	HC35370	HC50370	HC75370	HC110370
38mm	HC25380	HC35380	HC50380	HC75380	HC110380
39mm	HC25390	HC35390	HC50390	HC75390	HC110390
40mm	HC25400	HC35400	HC50400	HC75400	HC110400
41mm	—	HC35410	HC50410	HC75410	HC110410
42mm	—	HC35420	HC50420	HC75420	HC110420
43mm	—	HC35430	HC50430	HC75430	HC110430
44mm	—	HC35440	HC50440	HC75440	HC110440
45mm	—	HC35450	HC50450	HC75450	HC110450
46mm	—	HC35460	HC50460	HC75460	HC110460



HC STANDARD SERIES

DIAMETER	HC35 TYPE	HC50 TYPE	HC75 TYPE	HC110 TYPE
DIA.	ITEM NO.	ITEM NO.	ITEM NO.	ITEM NO.
47mm	HC35470	HC50470	HC75470	HC110470
48mm	HC35480	HC50480	HC75480	HC110480
49mm	HC35490	HC50490	HC75490	HC110490
50mm	HC35500	HC50500	HC75500	HC110500
51mm	HC35510	HC50510	HC75510	HC110510
52mm	HC35520	HC50520	HC75520	HC110520
53mm	—	HC50530	HC75530	HC110530
54mm	—	HC50540	HC75540	HC110540
55mm	—	HC50550	HC75550	HC110550
56mm	—	HC50560	HC75560	HC110560
57mm	—	HC50570	HC75570	HC110570
58mm	—	HC50580	HC75580	HC110580
59mm	—	HC50590	HC75590	HC110590
60mm	—	HC50600	HC75600	HC110600
61mm	—	HC50610	HC75610	HC110610
62mm	—	HC50620	HC75620	HC110620
63mm	—	HC50630	HC75630	HC110630
64mm	—	HC50940	HC75640	HC110640
65mm	—	HC50650	HC75650	HC110650
66mm	—	HC50660	HC75660	HC110660
67mm	—	HC50670	HC75670	HC110670
68mm	—	HC50680	HC75680	HC110680
69mm	—	HC50690	HC75690	HC110690
70mm	—	HC50700	HC75700	HC110700
71mm	—	HCL50710F	—	—
72mm	—	HCL50720F	—	—
73mm	—	HCL50730F	—	—
74mm	—	HCL50740F	—	—
75mm	—	HCL50750F	—	—
76mm	—	HCL50760F	—	—
77mm	—	HCL50770F	—	—
78mm	—	HCL50780F	—	—
79mm	—	HCL50790F	—	—
80mm	—	HCL50800F	—	—
81mm	—	HCL50810F	—	—
82mm	—	HCL50820F	—	—
83mm	—	HCL50830F	—	—
84mm	—	HCL50840F	—	—
85mm	—	HCL50850F	—	—
86mm	—	HCL50860F	—	—
87mm	—	HCL50870F	—	—
88mm	—	HCL50880F	—	—
89mm	—	HCL50890F	—	—
90mm	—	HCL50900F	—	—
91mm	—	HCL50910F	—	—
92mm	—	HCL50920F	—	—
93mm	—	HCL50930F	—	—
94mm	—	HCL50940F	—	—
95mm	—	HCL50950F	—	—
96mm	—	HCL50960F	—	—
97mm	—	HCL50970F	—	—
98mm	—	HCL50980F	—	—
99mm	—	HCL50990F	—	—
100mm	—	HCL51000F	—	—

DIAMETER	HC25 TYPE	HC35 TYPE	HC50 TYPE	HC75 TYPE	HC110 TYPE
DIA.	ITEM NO.	ITEM NO.	ITEM NO.	ITEM NO.	ITEM NO.
Drilling depth	25mm	35mm	50mm	75mm	110mm
Effective length	40mm	50mm	70mm	90mm	120mm
1/2"	HC251270	HC351270	HC501270	—	—
9/16"	HC251429	HC351429	HC501429	—	—
5/8"	HC251588	HC351588	HC501588	—	—
11/16"	HC251746	HC351746	HC501746	—	—
3/4"	HC251905	HC351905	HC501905	HC751905	—
13/16"	HC252064	HC352064	HC502064	HC752064	—
7/8"	HC252223	HC352223	HC502223	HC752223	HC1102223
15/16"	HC252381	HC352381	HC502381	HC752381	HC1102381
1"	HC252540	HC352540	HC502540	HC752540	HC1102540
1-1/16"	HC252699	HC352699	HC502699	HC752699	HC1102699
1-1/8"	HC252858	HC352858	HC502858	HC752858	HC1102858
1-3/16"	HC253016	HC353016	HC503016	HC753016	HC1103016
1-1/4"	HC253175	HC353175	HC503175	HC753175	HC1103175
1-5/16"	HC253334	HC353334	HC503334	HC753334	HC1103334
1-3/8"	HC253493	HC353493	HC503493	HC753493	HC1103493
1-7/16"	HC253651	HC353651	HC503651	HC753651	HC1103651
1-1/2"	HC253810	HC353810	HC503810	HC753810	HC1103810
1-9/16"	—	HC353969	HC503969	HC753969	HC1103969
1-5/8"	—	HC354128	HC504128	HC754128	HC1104128
1-11/16"	—	HC354286	HC504286	HC754286	HC1104286
1-3/4"	—	HC354445	HC504445	HC754445	HC1104445
1-13/16"	—	HC354604	HC504604	HC754604	HC1104604
1-7/8"	—	HC354763	HC504763	HC754763	HC1104763
1-15/16"	—	HC354921	HC504921	HC754921	HC1104921
2"	—	HC355080	HC505080	HC755080	HC1105080
2-1/16"	—	HC355239	HC505239	—	HC1105239
2-1/8"	—	HC355398	HC505398	HC755398	HC1105398
2-3/16"	—	HC355556	HC505556	—	—
2-1/4"	—	HC355715	HC505715	HC755715	HC1105715
2-5/16"	—	HC355874	HC505874	—	HC1105874
2-3/8"	—	—	HC506033	—	—
2-7/16"	—	HC356191	HC506191	—	—
2-1/2"	—	—	HC506350	—	—
2-9/16"	—	—	HC506509	—	—
2-5/8"	—	—	HC506668	—	—
2-3/4"	—	—	HC506985	HC756985	—
2-7/8"	—	—	HC507303	—	—
3"	—	—	HC507620	HC757620	—
3-1/8"	—	—	HC507938	—	—
3-1/4"	—	—	HC508255	—	—
3-1/2"	—	—	HC508890	—	—
3-3/4"	—	—	HC509525	—	—
3-7/8"	—	—	HC509843	—	—



HC TIN SERIES

- Material: Tungsten Carbide Micro Grade
- Drilling depth: 25mm, 35mm, 50mm, 75mm, 110mm
- Effective length: 40mm, 50mm, 70mm, 90mm, 120mm
- Special designed cutting edges.
- The special tooth arrangement makes cutting smooth.
- Can be run at higher speeds and higher feed rates.
- Can bore steel and for heavy-duty works.



HEAVY-DUTY
Ø 12mm ~ Ø 70mm

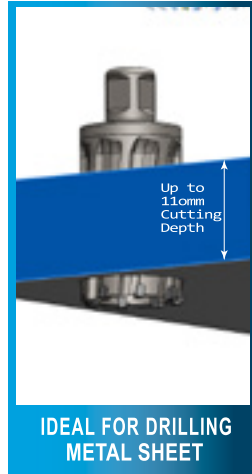

APPLICATIONS



HEAVY-DUTY



MAGNETIC DRILLING MACHINE



METAL SHEETS SUS304













METAL SHEETS SS41







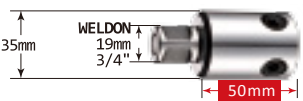

ALUMINUM

(See page 74 for more cutter's application)

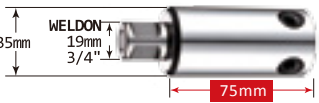
	TYPE	PIN	
HC25 TIN	 40mm	 75L	HC25 TIN
ITEM NO.	φ14mm~40mm / φ1/2"~1-1/2"	SHC30675P φ6.34mm×4.8mm×75L	
HC35 TIN	 50mm	 85L 91L 91L	HC35 TIN
ITEM NO.	φ12mm~13mm / φ1/2" φ14mm~15mm / φ9/16" φ16mm~52mm / φ5/8"~2-7/16"	1 HC35485P φ4.75mm×3.6mm×85L 2 HC35791P φ7.1mm x 5.8mm x 91L 3 HC35891P φ8.0mm×91L	
HC50 TIN	 70mm	 100L 112L 112L	HC50 TIN
ITEM NO.	φ12mm~13mm / φ1/2" φ14mm~17mm / φ9/16"~5/8" φ17.5mm~70mm / φ11/16"~2-1/2"	1 SHC554100P φ4.74mm×3.6mm×100L 2 HC506112P φ6.34mm x112L 3 HC508112P φ8.0mm×112L	
HC75 TIN	 90mm	 138L	HC75 TIN
ITEM NO.	φ16mm~70mm / φ3/4"~3"	HC758138P φ8.0mm×138L	
HC110 TIN	 120mm	 175L	HC110 TIN
ITEM NO.	φ18mm~70mm / φ7/8"~2-1/4"	HC1108175P φ8.0mm×175L	

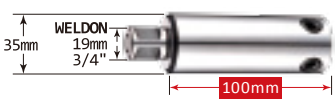
ADAPTER		TYPE		▶▶▶				
<p>FEIN Quick-In 18mm</p>  <p>WELDON 19mm 3/4"</p> <p>AD32100F</p>	+	 <p>▲ WELDON SHANK</p>	+					
<p>HITACHI /THREAD</p>  <p>WELDON 19mm 3/4"</p> <p>AD32200H</p>								
<p>NITTO 19mm</p>  <p>WELDON 19mm 3/4"</p> <p>AD32300N</p>								
<p>ALFRA 19mm</p>  <p>WELDON 19mm 3/4"</p> <p>AD32400A</p>								
<p>WELDON 19mm</p>  <p>NITTO 19mm 3/4"</p> <p>AD32500W</p>								

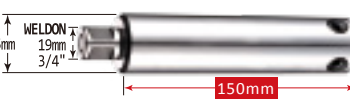
EXTENSIONS		TYPE		
<p>WELDON 19mm 3/4"</p>  <p>35mm</p> <p>ED10500 50L</p> <p>50mm</p>	+	 <p>▲ WELDON SHANK</p>		
<p>WELDON 19mm 3/4"</p>  <p>35mm</p> <p>ED10750 75L</p> <p>75mm</p>			 <p>▲ WELDON SHANK</p>	
<p>WELDON 19mm 3/4"</p>  <p>35mm</p> <p>ED101000 100L</p> <p>100mm</p>				 <p>▲ WELDON SHANK</p>
<p>WELDON 19mm 3/4"</p>  <p>35mm</p> <p>ED101500 150L</p> <p>150mm</p>				



T.C.T. CUTTER
Can afford heavy-duty drills.

Tungsten Carbide Tipped

Cutting Edges

It can be run at higher feed rate and speed to create holes of exceptional precision and cleanliness.

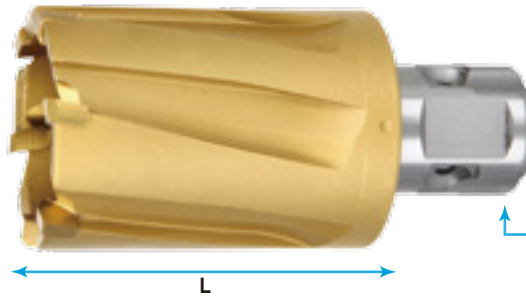

Entirely Fluted
Provides better chip clearance and offers higher cutting performance.

Shank
Different shank types to meet customer's demand.

DIAMETER	HC25 TIN TYPE	HC35 TIN TYPE	HC50 TIN TYPE	HC75 TIN TYPE	HC110 TIN TYPE
Drilling depth	25mm	35mm	50mm	75mm	110mm
Effective length	40mm	50mm	70mm	90mm	120mm
Shank diameter	φ19.05mm	φ19.05mm	φ19.05mm (below 70mm) φ31.75mm X 34L (above 71mm)	φ19.05mm	φ19.05mm

DIA.	ITEM NO.	ITEM NO.	ITEM NO.	ITEM NO.	ITEM NO.
12mm	—	HC35120TIN	HC50120TIN	—	—
13mm	—	HC35130TIN	HC50130TIN	—	—
14mm	HC25140TIN	HC35140TIN	HC50140TIN	—	—
15mm	HC25150TIN	HC35150TIN	HC50150TIN	—	—
16mm	HC25160TIN	HC35160TIN	HC50160TIN	HC75160TIN	—
17mm	HC25170TIN	HC35170TIN	HC50170TIN	HC75170TIN	—
17.5mm	—	HC35175TIN	HC50175TIN	—	—
18mm	HC25180TIN	HC35180TIN	HC50180TIN	HC75180TIN	HC110180TIN
19mm	HC25190TIN	HC35190TIN	HC50190TIN	HC75190TIN	HC110190TIN
20mm	HC25200TIN	HC35200TIN	HC50200TIN	HC75200TIN	HC110200TIN
21mm	HC25210TIN	HC35210TIN	HC50210TIN	HC75210TIN	HC110210TIN
22mm	HC25220TIN	HC35220TIN	HC50220TIN	HC75220TIN	HC110220TIN
22.5mm	—	HC35225TIN	—	—	—
23mm	HC25230TIN	HC35230TIN	HC50230TIN	HC75230TIN	HC110230TIN
23.5mm	—	HC35235TIN	—	—	—
24mm	HC25240TIN	HC35240TIN	HC50240TIN	HC75240TIN	HC110240TIN
24.5mm	—	HC35245TIN	HC50245TIN	—	—
25mm	HC25250TIN	HC35250TIN	HC50250TIN	HC75250TIN	HC110250TIN
25.5mm	—	HC35255TIN	—	—	—
26mm	HC25260TIN	HC35260TIN	HC50260TIN	HC75260TIN	HC110260TIN
26.5mm	—	HC35265TIN	HC50265TIN	—	—
27mm	HC25270TIN	HC35270TIN	HC50270TIN	HC75270TIN	HC110270TIN
28mm	HC25280TIN	HC35280TIN	HC50280TIN	HC75280TIN	HC110280TIN
29mm	HC25290TIN	HC35290TIN	HC50290TIN	HC75290TIN	HC110290TIN
30mm	HC25300TIN	HC35300TIN	HC50300TIN	HC75300TIN	HC110300TIN
31mm	HC25310TIN	HC35310TIN	HC50310TIN	HC75310TIN	HC110310TIN
32mm	HC25320TIN	HC35320TIN	HC50320TIN	HC75320TIN	HC110320TIN
33mm	HC25330TIN	HC35330TIN	HC50330TIN	HC75330TIN	HC110330TIN
34mm	HC25340TIN	HC35340TIN	HC50340TIN	HC75340TIN	HC110340TIN
35mm	HC25350TIN	HC35350TIN	HC50350TIN	HC75350TIN	HC110350TIN
36mm	HC25360TIN	HC35360TIN	HC50360TIN	HC75360TIN	HC110360TIN
37mm	HC25370TIN	HC35370TIN	HC50370TIN	HC75370TIN	HC110370TIN
38mm	HC25380TIN	HC35380TIN	HC50380TIN	HC75380TIN	HC110380TIN
39mm	HC25390TIN	HC35390TIN	HC50390TIN	HC75390TIN	HC110390TIN
40mm	HC25400TIN	HC35400TIN	HC50400TIN	HC75400TIN	HC110400TIN
41mm	—	HC35410TIN	HC50410TIN	HC75410TIN	HC110410TIN
42mm	—	HC35420TIN	HC50420TIN	HC75420TIN	HC110420TIN
43mm	—	HC35430TIN	HC50430TIN	HC75430TIN	HC110430TIN
44mm	—	HC35440TIN	HC50440TIN	HC75440TIN	HC110440TIN
45mm	—	HC35450TIN	HC50450TIN	HC75450TIN	HC110450TIN
46mm	—	HC35460TIN	HC50460TIN	HC75460TIN	HC110460TIN



HC TIN SERIES

DIAMETER	HC35 TIN TYPE	HC50 TIN TYPE	HC75 TIN TYPE	HC110 TIN TYPE	DIAMETER	HC25 TIN TYPE	HC35 TIN TYPE	HC50 TIN TYPE	HC75 TIN TYPE	HC110 TIN TYPE
DIA.	ITEM NO.	ITEM NO.	ITEM NO.	ITEM NO.	DIA.	ITEM NO.	ITEM NO.	ITEM NO.	ITEM NO.	ITEM NO.
47mm	HC35470TIN	HC50470TIN	HC75470TIN	HC110470TIN	Drilling depth	25mm	35mm	50mm	75mm	110mm
48mm	HC35480TIN	HC50480TIN	HC75480TIN	HC110480TIN	Effective length	40mm	50mm	70mm	90mm	120mm
49mm	HC35490TIN	HC50490TIN	HC75490TIN	HC110490TIN		1/2"	HC251270	HC351270	HC501270	—
50mm	HC35500TIN	HC50500TIN	HC75500TIN	HC110500TIN	9/16"	HC251429	HC351429	HC501429	—	—
51mm	HC35510TIN	HC50510TIN	HC75510TIN	HC110510TIN	5/8"	HC251588	HC351588	HC501588	—	—
52mm	HC35520TIN	HC50520TIN	HC75520TIN	HC110520TIN	11/16"	HC251746	HC351746	HC501746	—	—
53mm	—	HC50530TIN	HC75530TIN	HC110530TIN	3/4"	HC251905	HC351905	HC501905	HC751905	—
54mm	—	HC50540TIN	HC75540TIN	HC110540TIN	13/16"	HC252064	HC352064	HC502064	HC752064	—
55mm	—	HC50550TIN	HC75550TIN	HC110550TIN	7/8"	HC252223	HC352223	HC502223	HC752223	HC1102223
56mm	—	HC50560TIN	HC75560TIN	HC110560TIN	15/16"	HC252381	HC352381	HC502381	HC752381	HC1102381
57mm	—	HC50570TIN	HC75570TIN	HC110570TIN	1"	HC252540	HC352540	HC502540	HC752540	HC1102540
58mm	—	HC50580TIN	HC75580TIN	HC110580TIN	1-1/16"	HC252699	HC352699	HC502699	HC752699	HC1102699
59mm	—	HC50590TIN	HC75590TIN	HC110590TIN	1-1/8"	HC252858	HC352858	HC502858	HC752858	HC1102858
60mm	—	HC50600TIN	HC75600TIN	HC110600TIN	1-3/16"	HC253016	HC353016	HC503016	HC753016	HC1103016
61mm	—	HC50610TIN	HC75610TIN	HC110610TIN	1-1/4"	HC253175	HC353175	HC503175	HC753175	HC1103175
62mm	—	HC50620TIN	HC75620TIN	HC110620TIN	1-5/16"	HC253334	HC353334	HC503334	HC753334	HC1103334
63mm	—	HC50630TIN	HC75630TIN	HC110630TIN	1-3/8"	HC253493	HC353493	HC503493	HC753493	HC1103493
64mm	—	HC50940TIN	HC75640TIN	HC110640TIN	1-7/16"	HC253651	HC353651	HC503651	HC753651	HC1103651
65mm	—	HC50650TIN	HC75650TIN	HC110650TIN	1-1/2"	HC253810	HC353810	HC503810	HC753810	HC1103810
66mm	—	HC50660TIN	HC75660TIN	HC110660TIN	1-9/16"	—	HC353969	HC503969	HC753969	HC1103969
67mm	—	HC50670TIN	HC75670TIN	HC110670TIN	1-5/8"	—	HC354128	HC504128	HC754128	HC1104128
68mm	—	HC50680TIN	HC75680TIN	HC110680TIN	1-11/16"	—	HC354286	HC504286	HC754286	HC1104286
69mm	—	HC50690TIN	HC75690TIN	HC110690TIN	1-3/4"	—	HC354445	HC504445	HC754445	HC1104445
70mm	—	HC50700TIN	HC75700TIN	HC110700TIN	1-13/16"	—	HC354604	HC504604	HC754604	HC1104604
71mm	—	HCL50710F	—	—	1-7/8"	—	HC354763	HC504763	HC754763	HC1104763
72mm	—	HCL50720F	—	—	1-15/16"	—	HC354921	HC504921	HC754921	HC1104921
73mm	—	HCL50730F	—	—	2"	—	HC355080	HC505080	HC755080	HC1105080
74mm	—	HCL50740F	—	—	2-1/16"	—	HC355239	HC505239	—	HC1105239
75mm	—	HCL50750F	—	—	2-1/8"	—	HC355398	HC505398	HC755398	HC1105398
76mm	—	HCL50760F	—	—	2-3/16"	—	HC355556	HC505556	—	—
77mm	—	HCL50770F	—	—	2-1/4"	—	HC355715	HC505715	HC755715	HC1105715
78mm	—	HCL50780F	—	—	2-5/16"	—	HC355874	HC505874	—	HC1105874
79mm	—	HCL50790F	—	—	2-3/8"	—	—	HC506033	—	—
80mm	—	HCL50800F	—	—	2-7/16"	—	HC356191	HC506191	—	—
81mm	—	HCL50810F	—	—	2-1/2"	—	—	HC506350	—	—
82mm	—	HCL50820F	—	—	2-9/16"	—	—	HC506509	—	—
83mm	—	HCL50830F	—	—	2-5/8"	—	—	HC506668	—	—
84mm	—	HCL50840F	—	—	2-3/4"	—	—	HC506985	HC756985	—
85mm	—	HCL50850F	—	—	2-7/8"	—	—	HC507303	—	—
86mm	—	HCL50860F	—	—	3"	—	—	HC507620	HC757620	—
87mm	—	HCL50870F	—	—	3-1/8"	—	—	HC507938	—	—
88mm	—	HCL50880F	—	—	3-1/4"	—	—	HC508255	—	—
89mm	—	HCL50890F	—	—	3-1/2"	—	—	HC508890	—	—
90mm	—	HCL50900F	—	—	3-3/4"	—	—	HC509525	—	—
91mm	—	HCL50910F	—	—	3-7/8"	—	—	HC509843	—	—
92mm	—	HCL50920F	—	—						
93mm	—	HCL50930F	—	—						
94mm	—	HCL50940F	—	—						
95mm	—	HCL50950F	—	—						
96mm	—	HCL50960F	—	—						
97mm	—	HCL50970F	—	—						
98mm	—	HCL50980F	—	—						
99mm	—	HCL50990F	—	—						
100mm	—	HCL51000F	—	—						

TCT HOLE CUTTER / HC TIN



HC SERIES SET

- HC Hole Cutter kit has 6 pieces of Hole Cutter in different sizes.
- Select Hole Cutter ranging from 14mm to 26mm diameter.

HC SET

SHAJENG HARDWARE CO., LTD

HC SET 1

SPECIFICATION

HC Type	HC35 Standard / HC35 TIN
Material	Tungsten Carbide Micro Grade
Drilling Depth	35mm
Effective Length	50mm
Minimum Hole Cutter Diameter(mm)	14mm
Maximum Hole Cutter Diameter(mm)	26mm
Kit Includes	(6) Hole Cutters; (2) Pilot Pins
Number of Pieces	8



HC SET 2

SPECIFICATION

HC Type	HC50 Standard / HC50 TIN
Material	Tungsten Carbide Micro Grade
Drilling Depth	50mm
Effective Length	70mm
Minimum Hole Cutter Diameter(mm)	14mm
Maximum Hole Cutter Diameter(mm)	26mm
Kit Includes	(6) Hole Cutters; (2) Pilot Pins
Number of Pieces	8



HC50S TYPE

- Material: Tungsten Carbide Micro Grade
- Drilling depth: 50mm
- Effective length: 70mm
- Special designed cutting edges.
- The special tooth arrangement makes cutting smooth.
- Threaded retainer.

HEAVY-DUTY
Ø 12mm ~ Ø 80mm

APPLICABLE MACHINE

Hitachi magnetic drilling machines

APPLICATIONS

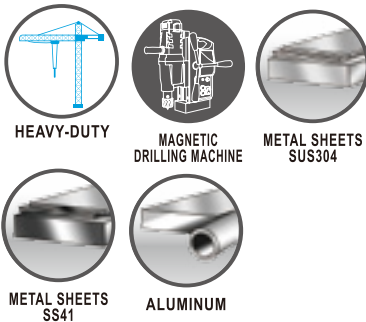

(See page 74 for more cutter's application)

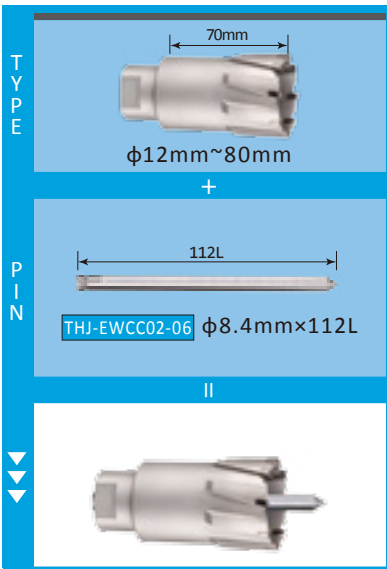
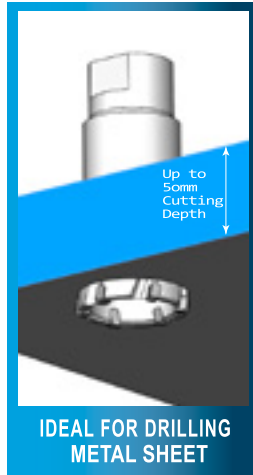

DIAMETER	HC50S TYPE
Drilling depth	50mm
Effective length	70mm

DIA.	ITEM NO.
2-1/2"	HC50S6350
2-9/16"	HC50S6509
2-5/8"	HC50S6668
2-3/4"	HC50S6985
2-7/8"	HC50S7303
2-15/16"	HC50S7461
3"	HC50S7620
3-1/16"	HC50S7779
3-1/8"	HC50S7938
4"	HC50S10160

DIA.	ITEM NO.	DIA.	ITEM NO.
12mm	HC50S120	38mm	HC50S380
13mm	HC50S130	39mm	HC50S390
14mm	HC50S140	40mm	HC50S400
15mm	HC50S150	41mm	HC50S410
16mm	HC50S160	42mm	HC50S420
17mm	HC50S170	43mm	HC50S430
18mm	HC50S180	44mm	HC50S440
19mm	HC50S190	45mm	HC50S450
20mm	HC50S200	46mm	HC50S460
21mm	HC50S210	47mm	HC50S470
22mm	HC50S220	48mm	HC50S480
23mm	HC50S230	49mm	HC50S490
24mm	HC50S240	50mm	HC50S500
25mm	HC50S250	51mm	HC50S510
26mm	HC50S260	52mm	HC50S520
27mm	HC50S270	53mm	HC50S530
28mm	HC50S280	54mm	HC50S540
29mm	HC50S290	55mm	HC50S550
30mm	HC50S300	60mm	HC50S600
31mm	HC50S310	65mm	HC50S650
32mm	HC50S320	70mm	HC50S700
33mm	HC50S330	75mm	HC50S750
34mm	HC50S340	80mm	HC50S800
35mm	HC50S350		
36mm	HC50S360		
37mm	HC50S370		

HCD SERIES

- Material: Tungsten Carbide Micro Grade
- Drilling depth: 35mm, 50mm, 75mm, 110mm
- Effective length: 50mm, 70mm, 90mm, 120mm
- Using the combination of stacked plate.
- Reduces wear while drillings.
- Produces smoother surface with multiple teeth.
- The cutters cut at a limited range thus saving machine power.

HIGH PERFORMANCE **SUPER HEAVY-DUTY**
Ø 16mm ~ Ø 50mm

APPLICATIONS

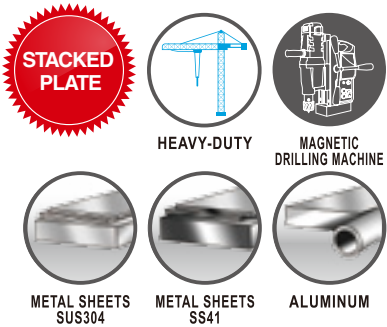

(See page 74 for more cutter's application)

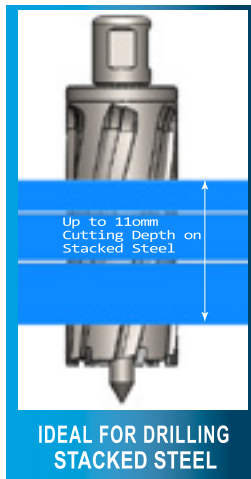





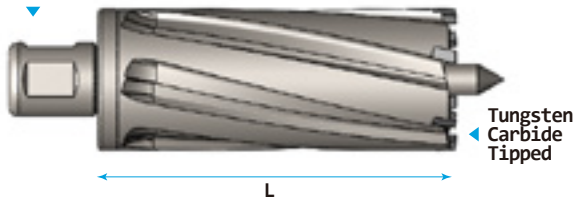

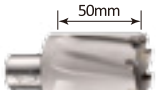
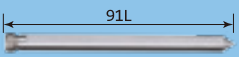

ADVANTAGES

Shank
Any types of Shanks

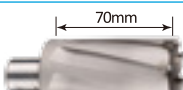
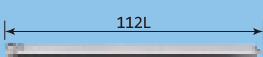

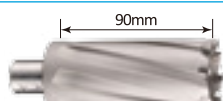
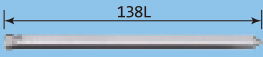
Pin insert

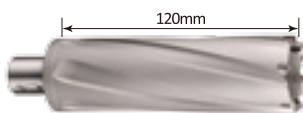
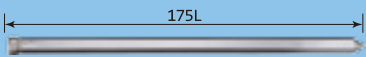

	TYPE		PIN		
HCD35	 50mm	+	 91L	=	HCD35 
ITEM NO.	φ16mm~52mm / φ1/2"~2"	→	HC35891P φ8.0mm×91L		
HCD50	 70mm	+	 112L	=	HCD50 
ITEM NO.	φ22mm~50mm / φ7/8"~2"	→	HC508112P φ8.0mm×112L		
HCD75	 90mm	+	 138L	=	HCD75 
ITEM NO.	φ22mm~50mm / φ13/16"~2-1/2"	→	HC758138P φ8.0mm×138L		
HCD110	 120mm	+	 175L	=	HCD110 
ITEM NO.	φ22mm~50mm / φ13/16"~2-1/2"	→	HC1108175P φ8.0mm×175L		

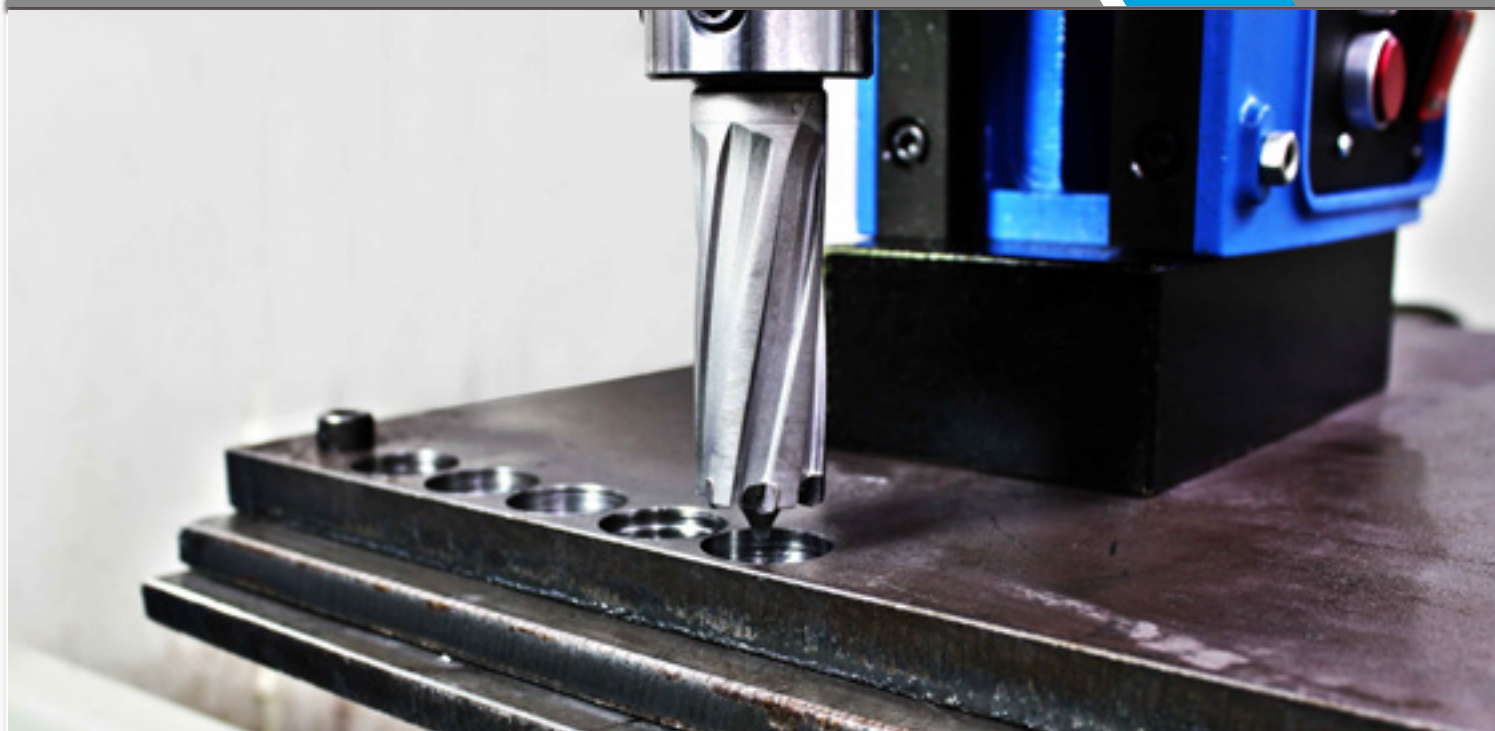

TCT HOLE CUTTER / HCD TYPE

DIAMETER	HCD35 TYPE	HCD50 TYPE	HCD75 TYPE	HCD110 TYPE	DIAMETER	HCD35 TYPE	HCD50 TYPE	HCD75 TYPE	HCD110 TYPE
Drilling depth	35mm	50mm	75mm	110mm	Drilling depth	35mm	50mm	75mm	110mm
Effective length	50mm	70mm	90mm	120mm	Effective length	50mm	70mm	90mm	120mm
DIA.	ITEM NO.	ITEM NO.	ITEM NO.	ITEM NO.	DIA.	ITEM NO.	ITEM NO.	ITEM NO.	ITEM NO.
16mm	HCD35160	—	—	—	1/2"	HCD351270	—	—	—
17mm	HCD35170	—	—	—	9/16"	HCD351429	—	—	—
18mm	HCD35180	—	—	—	5/8"	HCD351588	—	—	—
19mm	HCD35190	—	—	—	11/16"	HCD351746	—	—	—
20mm	HCD35200	—	—	—	3/4"	HCD351905	—	—	—
21mm	HCD35210	—	—	—	13/16"	HCD352064	—	HCD752064	HCD1102064
22mm	HCD35220	HCD50220	HCD75220	HCD110220	7/8"	HCD352223	HCD502223	HCD752223	HCD1102223
23mm	HCD35230	HCD50230	HCD75230	HCD110230	15/16"	HCD352381	HCD502381	HCD752381	HCD1102381
24mm	HCD35240	HCD50240	HCD75240	HCD110240	1"	HCD352540	HCD502540	HCD752540	HCD1102540
25mm	HCD35250	HCD50250	HCD75250	HCD110250	1-1/16"	HCD352699	HCD502699	HCD752699	HCD1102699
26mm	HCD35260	HCD50260	HCD75260	HCD110260	1-1/8"	HCD352858	HCD502858	HCD752858	HCD1102858
27mm	HCD35270	HCD50270	HCD75270	HCD110270	1-3/16"	HCD353016	HCD503016	HCD753016	HCD1103016
28mm	HCD35280	HCD50280	HCD75280	HCD110280	1-1/4"	HCD353175	HCD503175	HCD753175	HCD1103175
29mm	HCD35290	HCD50290	HCD75290	HCD110290	1-5/16"	HCD353334	HCD503334	HCD753334	HCD1103334
30mm	HCD35300	HCD50300	HCD75300	HCD110300	1-3/8"	HCD353493	HCD503493	HCD753493	HCD1103493
31mm	HCD35310	HCD50310	HCD75310	HCD110310	1-7/16"	HCD353651	HCD503651	HCD753651	HCD1103651
32mm	HCD35320	HCD50320	HCD75320	HCD110320	1-1/2"	HCD353810	HCD503810	HCD753810	HCD1103810
33mm	HCD35330	HCD50330	HCD75330	HCD110330	1-9/16"	HCD353969	HCD503969	HCD753969	HCD1103969
34mm	HCD35340	HCD50340	HCD75340	HCD110340	1-5/8"	HCD354128	HCD504128	HCD754128	HCD1104128
35mm	HCD35350	HCD50350	HCD75350	HCD110350	1-11/16"	HCD354286	HCD504286	HCD754286	HCD1104286
36mm	HCD35360	HCD50360	HCD75360	HCD110360	1-3/4"	HCD354445	HCD504445	HCD754445	HCD1104445
37mm	HCD35370	HCD50370	HCD75370	HCD110370	1-13/16"	HCD354604	HCD504604	HCD754604	HCD1104604
38mm	HCD35380	HCD50380	HCD75380	HCD110380	1-7/8"	HCD354763	HCD504763	HCD754763	HCD1104763
39mm	HCD35390	HCD50390	HCD75390	HCD110390	1-15/16"	HCD354921	HCD504921	HCD754921	HCD1104921
40mm	HCD35400	HCD50400	HCD75400	HCD110400	2"	HCD355080	HCD505080	HCD755080	HCD1105080
41mm	HCD35410	HCD50410	HCD75410	HCD110410	2-1/8"	—	—	HCD755398	HCD1105398
42mm	HCD35420	HCD50420	HCD75420	HCD110420	2-1/4"	—	—	HCD755715	HCD1105715
43mm	HCD35430	HCD50430	HCD75430	HCD110430	2-1/2"	—	—	HCD756350	HCD1106350
44mm	HCD35440	HCD50440	HCD75440	HCD110440					
45mm	HCD35450	HCD50450	HCD75450	HCD110450					
46mm	HCD35460	HCD50460	HCD75460	HCD110460					
47mm	HCD35470	HCD50470	HCD75470	HCD110470					
48mm	HCD35480	HCD50480	HCD75480	HCD110480					
49mm	HCD35490	HCD50490	HCD75490	HCD110490					
50mm	HCD35500	HCD50500	HCD75500	HCD110500					



HCL TYPE

SHAJENG HARDWARE CO., LTD



HCL SERIES

- Material: Tungsten Carbide Micro Grade
- Drilling depth: 50mm, 75mm, 110mm
- Effective length: 70mm, 95mm, 120mm
- With its extremely sharp Tungsten Carbide Tipped cutting edges, it can be run at higher feed rate and speed to create holes of exceptional precision and cleanliness.

HIGH PERFORMANCE **SUPER HEAVY-DUTY**
Ø 50mm ~ Ø 150mm

APPLICATIONS



HEAVY-DUTY

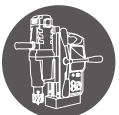

MAGNETIC DRILLING MACHINE



METAL SHEETS SUS304



METAL SHEETS SS41





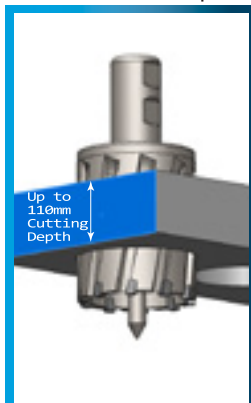

ALUMINUM



IDEAL FOR DRILLING THICK STEEL

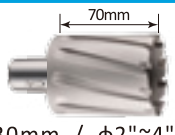

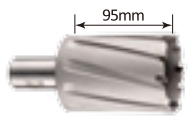
(See page 74 for more cutter's application)

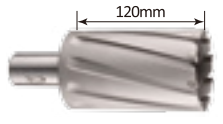
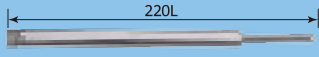
	TYPE	PIN	
HCL50F			HCL50F
ITEM NO.	φ70mm~130mm / φ2"~4"	HC758138P φ8.0mm×138L	
HCL75			HCL75
ITEM NO.	φ50mm~150mm / φ2"~4"	HCL7512192P φ12mm×6mm×192L	
HCL110			HCL110
ITEM NO.	φ71mm~100mm / φ2"~4"	HCL11012220P φ12mm×6mm×220L	

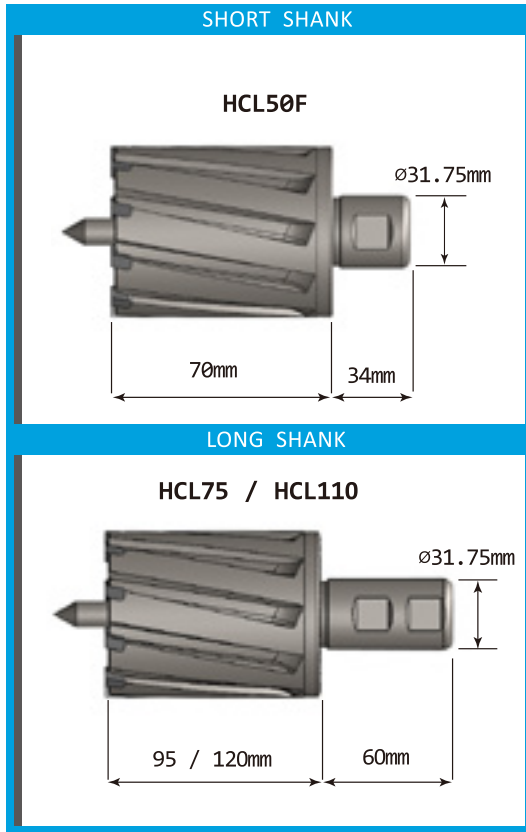

DIA.	HCL50F	HCL75	HCL110
Drilling depth	50mm	75mm	110mm
Effective length	70mm	95mm	120mm
Shank diameter	φ31.75mm	φ31.75mm	φ31.75mm

DIA.	ITEM NO.	ITEM NO.	ITEM NO.
50mm	—	HCL75500	—
51mm	—	HCL75510	—
52mm	—	HCL75520	—
53mm	—	HCL75530	—
54mm	—	HCL75540	—
55mm	—	HCL75550	—
56mm	—	HCL75560	—
57mm	—	HCL75570	—
58mm	—	HCL75580	—
59mm	—	HCL75590	—
60mm	—	HCL75600	—
61mm	—	HCL75610	—
62mm	—	HCL75620	—
63mm	—	HCL75630	—
64mm	—	HCL75640	—
65mm	—	HCL75650	—
66mm	—	HCL75660	—
67mm	—	HCL75670	—
68mm	—	HCL75680	—
69mm	—	HCL75690	—
70mm	HCL50700F	HCL75700	—
71mm	HCL50710F	HCL75710	HCL110710
72mm	HCL50720F	HCL75720	HCL110720
73mm	HCL50730F	HCL75730	HCL110730
74mm	HCL50740F	HCL75740	HCL110740
75mm	HCL50750F	HCL75750	HCL110750
76mm	HCL50760F	HCL75760	HCL110760

DIA.	ITEM NO.	TEM NO.	ITEM NO.
77mm	HCL50770F	HCL75770	HCL110770
78mm	HCL50780F	HCL75780	HCL110780
79mm	HCL50790F	HCL75790	HCL110790
80mm	HCL50800F	HCL75800	HCL110800
81mm	HCL50810F	HCL75810	HCL110810
82mm	HCL50820F	HCL75820	HCL110820
83mm	HCL50830F	HCL75830	HCL110830
84mm	HCL50840F	HCL75840	HCL110840
85mm	HCL50850F	HCL75850	HCL110850
86mm	HCL50860F	HCL75860	HCL110860
87mm	HCL50870F	HCL75870	HCL110870
88mm	HCL50880F	HCL75880	HCL110880
89mm	HCL50890F	HCL75890	HCL110890
90mm	HCL50900F	HCL75900	HCL110900
91mm	HCL50910F	HCL75910	HCL110910
92mm	HCL50920F	HCL75920	HCL110920
93mm	HCL50930F	HCL75930	HCL110930
94mm	HCL50940F	HCL75940	HCL110940
95mm	HCL50950F	HCL75950	HCL110950
96mm	HCL50960F	HCL75960	HCL110960
97mm	HCL50970F	HCL75970	HCL110970
98mm	HCL50980F	HCL75980	HCL110980
99mm	HCL50990F	HCL75990	HCL110990
100mm	HCL51000F	HCL751000	HCL1101000
105mm	HCL51050F	HCL751050	—
110mm	HCL51100F	HCL751100	—
115mm	HCL51150F	HCL751150	—
120mm	HCL51120F	HCL751200	—
125mm	HCL51250F	HCL751250	—
130mm	HCL51300F	HCL751300	—
135mm	—	HCL751350	—
140mm	—	HCL751400	—
145mm	—	HCL751450	—
150mm	—	HCL751500	—

DIA.	HCL50F	HCL75	HCL110
Drilling depth	50mm	75mm	110mm
Effective length	70mm	95mm	120mm
Shank diameter	φ31.75mm	φ31.75mm	φ31.75mm

DIA.	ITEM NO.	ITEM NO.	ITEM NO.
—	—	HCL755080	HCL1105080
2-1/16	—	HCL755239	HCL1105239
2-1/8	—	HCL755398	HCL1105398
2-3/16	—	HCL755556	HCL1105556
2-1/4	—	HCL755715	HCL1105715
2-5/16	—	HCL755874	HCL1105874
2-3/8	—	HCL756033	HCL1106033
2-7/16	—	HCL756191	HCL1106191
2-1/2	—	HCL756350	HCL1106350
2-9/16	—	HCL756509	HCL1106509
2-5/8	—	HCL756668	HCL1106668
2-3/4	—	HCL756985	HCL1106985
2-7/8	HCL507303F	HCL757303	HCL1107303
3"	HCL507620F	HCL757620	HCL1107620
3-1/8	HCL507938F	HCL757938	HCL1107938
3-1/4	HCL508255F	HCL758255	HCL1108255
3-1/2	HCL508890F	HCL758890	HCL1108890
3-3/4	HCL509525F	HCL759525	HCL1109525
3-7/8	—	HCL759843	HCL1109843
4"	—	HCL7510160	HCL11010160



HCR TYPE

Best for
**Stainless Steel,
Heat Treated Steel**



HEAVY-DUTY
Ø 18mm ~ Ø 50mm

- Material: Tungsten Carbide Micro Grade
- Drilling depth: 25mm, 35mm, 50mm
- Effective length: 41mm, 50mm, 70mm
- For horsepower machine
- Any brand of rail drilling machine
- With its extremely sharp Tungsten Carbide Tipped cutting edges, it can be run at higher feed rate and speed to create holes of exceptional precision and cleanliness.
- Application for stainless steel, heat treated steel and other hard materials.



HCR TYPE

SHAJENG HARDWARE CO., LTD

APPLICATIONS

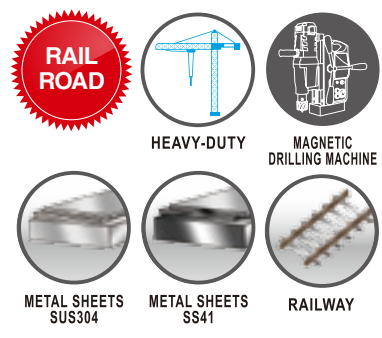







(See page 74 for more cutter's application)

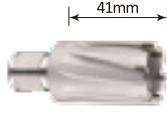
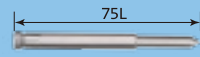

IDEAL FOR DRILLING RAIL WAY

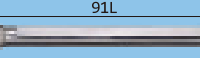
DIA.	2HCR25 TYPE	2HCR35 TYPE	2HCR50 TYPE	2HCR25 TYPE TIALN COATED	2HCR35 TYPE TIALN COATED	2HCR50 TYPE TIALN COATED
Drilling depth	25mm	35mm	50mm	25mm	35mm	50mm
Effective length	41mm	50mm	70mm	41mm	50mm	70mm
18mm	2HCR25180	2HCR35180	2HCR50180	2HCR25180TIA	2HCR35180TIA	2HCR50180TIA
19mm	2HCR25190	2HCR35190	2HCR50190	2HCR25190TIA	2HCR35190TIA	2HCR50190TIA
20mm	2HCR25200	2HCR35200	2HCR50200	2HCR25200TIA	2HCR35200TIA	2HCR50200TIA
21mm	2HCR25210	2HCR35210	2HCR50210	2HCR25210TIA	2HCR35210TIA	2HCR50210TIA
22mm	2HCR25220	2HCR35220	2HCR50220	2HCR25220TIA	2HCR35220TIA	2HCR50220TIA
23mm	2HCR25230	2HCR35230	2HCR50230	2HCR25230TIA	2HCR35230TIA	2HCR50230TIA
24mm	2HCR25240	2HCR35240	2HCR50240	2HCR25240TIA	2HCR35240TIA	2HCR50240TIA
25mm	2HCR25250	2HCR35250	2HCR50250	2HCR25250TIA	2HCR35250TIA	2HCR50250TIA
26mm	2HCR25260	2HCR35260	2HCR50260	2HCR25260TIA	2HCR35260TIA	2HCR50260TIA
27mm	2HCR25270	2HCR35270	2HCR50270	2HCR25270TIA	2HCR35270TIA	2HCR50270TIA
28mm	2HCR25280	2HCR35280	2HCR50280	2HCR25280TIA	2HCR35280TIA	2HCR50280TIA
29mm	2HCR25290	2HCR35290	2HCR50290	2HCR25290TIA	2HCR35290TIA	2HCR50290TIA
30mm	2HCR25300	2HCR35300	2HCR50300	2HCR25300TIA	2HCR35300TIA	2HCR50300TIA
31mm	2HCR25310	2HCR35310	2HCR50310	2HCR25310TIA	2HCR35310TIA	2HCR50310TIA
32mm	2HCR25320	2HCR35320	2HCR50320	2HCR25320TIA	2HCR35320TIA	2HCR50320TIA
33mm	2HCR25330	2HCR35330	2HCR50330	2HCR25330TIA	2HCR35330TIA	2HCR50330TIA
34mm	2HCR25340	2HCR35340	2HCR50340	2HCR25340TIA	2HCR35340TIA	2HCR50340TIA
35mm	2HCR25350	2HCR35350	2HCR50350	2HCR25350TIA	2HCR35350TIA	2HCR50350TIA
36mm	2HCR25360	2HCR35360	2HCR50360	2HCR25360TIA	2HCR35360TIA	2HCR50360TIA

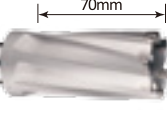
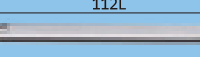

	TYPE		PIN		
2HCR25 ITEM NO.	 41mm φ18mm~50mm	+	 75L SHC30675P φ6.34mm×4.8mm×75L	=	 2HCR25
2HCR35 ITEM NO.	 50mm φ18mm~50mm	+	 91L HC35891P φ8.0mm×91L	=	 2HCR35
2HCR50 ITEM NO.	 70mm φ18mm~50mm	+	 112L HC508112P φ8.0mm×112L	=	 2HCR50

DIA.	2HCR25 TYPE	2HCR35 TYPE	2HCR50 TYPE	2HCR25 TYPE TIALN COATED	2HCR35 TYPE TIALN COATED	2HCR50 TYPE TIALN COATED
37mm	2HCR25370	2HCR35370	2HCR50370	2HCR25370TIA	2HCR35370TIA	2HCR50370TIA
38mm	2HCR25380	2HCR35380	2HCR50380	2HCR25380TIA	2HCR35380TIA	2HCR50380TIA
39mm	2HCR25390	2HCR35390	2HCR50390	2HCR25390TIA	2HCR35390TIA	2HCR50390TIA
40mm	2HCR25400	2HCR35400	2HCR50400	2HCR25400TIA	2HCR35400TIA	2HCR50400TIA
41mm	2HCR25410	2HCR35410	2HCR50410	2HCR25410TIA	2HCR35410TIA	2HCR50410TIA
42mm	2HCR25420	2HCR35420	2HCR50420	2HCR25420TIA	2HCR35420TIA	2HCR50420TIA
43mm	2HCR25430	2HCR35430	2HCR50430	2HCR25430TIA	2HCR35430TIA	2HCR50430TIA
44mm	2HCR25440	2HCR35440	2HCR50440	2HCR25440TIA	2HCR35440TIA	2HCR50440TIA
45mm	2HCR25450	2HCR35450	2HCR50450	2HCR25450TIA	2HCR35450TIA	2HCR50450TIA
46mm	2HCR25460	2HCR35460	2HCR50460	2HCR25460TIA	2HCR35460TIA	2HCR50460TIA
47mm	2HCR25470	2HCR35470	2HCR50470	2HCR25470TIA	2HCR35470TIA	2HCR50470TIA
48mm	2HCR25480	2HCR35480	2HCR50480	2HCR25480TIA	2HCR35480TIA	2HCR50480TIA
49mm	2HCR25490	2HCR35490	2HCR50490	2HCR25490TIA	2HCR35490TIA	2HCR50490TIA
50mm	2HCR25500	2HCR35500	2HCR50500	2HCR25500TIA	2HCR35500TIA	2HCR50500TIA



HSS HOLE CUTTER

All features in comparison.



	SHC SERIES	SHC SERIES TIA	SHCO SERIES	SHCO SERIES TIA
DIAMETER	SHC30 SHC55 SHC75 SHC110	SHC30 TIA SHC55 TIA SHC75 TIA SHC110 TIA	SHCO30 M42 SHCO55 M42 SHCO75 M42 SHCO110 M42	SHCO30 M42 IN TIA SHCO55 M42 IN TIA SHCO75 M42 IN TIA SHCO110 M42 IN TIA

Application Guide

	Metal Sheets SUS304	★	★	★	★
	Metal Sheets SS41	★★★	★★★	★★★	★★★
	Steel Pipes SUS304	★	★	★	★
	Steel Pipes SS41	★★★	★★★	★★★	★★★
	Cast Iron	★★★	★★★	★★★	★★★
	Aluminum	★★	★★	★★	★★
	Copper	★★	★★	★★	★★
	Bronze	★★	★★	★★	★★
	I-Beam	★★★	★★★	★★★	★★★
	Fiber Glass				





	SHC SERIES	SHC SERIES TIA	SHCO SERIES	SHCO SERIES TIA
DIAMETER	SHC30 SHC55 SHC75 SHC110	SHC30 TIA SHC55 TIA SHC75 TIA SHC110 TIA	SHCO30 M42 SHCO55 M42 SHCO75 M42 SHCO110 M42	SHCO30 M42 IN TIA SHCO55 M42 IN TIA SHCO75 M42 IN TIA SHCO110 M42 IN TIA

Application Guide

	L-Bar	★★★	★★★	★★★	★★★
	Concrete				
	Masonry				
	PVC Pipes				
	Railway				
	Heat Treated Steel				
	Square pipe	★★★	★★★	★★★	★★★
	Stacked Steel				
	Wood				
	Wood With Nails				

★★★ : Excellent, ★★ : Good, ★ : Fair



SHC STANDARD SERIES

- Material: M2 High Speed Steel
- Drilling depth: 30mm, 55mm, 75mm, 110mm
- Effective length: 35mm, 60mm, 80mm, 115mm
- Faster feed rates are reached with more cutting teeth.
- Can drill holes three times faster than traditional hole making tools.
- The cutting edges can be re-sharpened.
- For high precision metal sheet drilling.
- Produces smoother surface.

HIGH PERFORMANCE

HEAVY-DUTY

Ø 12mm ~ Ø 70mm

APPLICATIONS

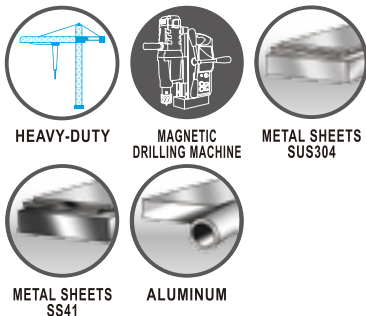

(See page 92 for more cutter's application)

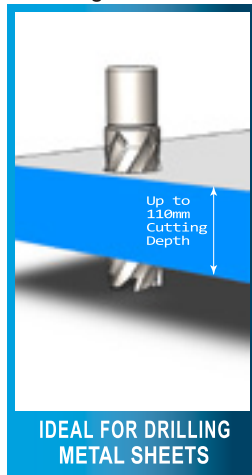

	TYPE	PIN	
SHC30 M2 ITEM NO.	35mm Ø12mm~13mm / Ø1/2"	+ 75L	= SHC30 M2
SHC30 M2 ITEM NO.	35mm Ø14mm~70mm / Ø9/16"~2~3/4"	+ 75L	= SHC30 M2
SHC55 M2 ITEM NO.	60mm Ø12mm~13mm / Ø1/2"	+ 100L	= SHC55 M2
SHC55 M2 ITEM NO.	60mm Ø14mm~70mm / Ø9/16"~2~3/4"	+ 100L	= SHC55 M2
SHC75 M2 ITEM NO.	80mm Ø20mm~50mm / Ø13/16"~2"	+ 125L	= SHC75 M2
SHC110 M2 ITEM NO.	115mm Ø20mm~50mm / Ø13/16"~2"	+ 150L	= SHC110 M2



DIA.	SHC30 TYPE	SHC55 TYPE	SHC75 TYPE	SHC110 TYPE
Drilling depth	30mm	55mm	75mm	110mm
Effective length	35mm	60mm	80mm	115mm
1/2"	SHC301270	SHC551270	—	—
9/16"	SHC301429	SHC551429	—	—
5/8"	SHC301588	SHC551588	—	—
11/16"	SHC301746	SHC551746	—	—
3/4"	SHC301905	SHC551905	—	—
13/16"	SHC302064	SHC552064	SHC752064	SHC1102064
7/8"	SHC302223	SHC552223	SHC752223	SHC1102223
15/16"	SHC302381	SHC552381	SHC752381	SHC1102381
1"	SHC302540	SHC552540	SHC752540	SHC1102540
1-1/16"	SHC302699	SHC552699	SHC752699	SHC1102699
1-1/8"	SHC302858	SHC552858	SHC752858	SHC1102858
1-3/16"	SHC303016	SHC553016	SHC753016	SHC1103016
1-1/4"	SHC303175	SHC553175	SHC753175	SHC1103175
1-5/16"	SHC303334	SHC553334	SHC753334	SHC1103334
1-3/8"	SHC303493	SHC553493	SHC753493	SHC1103493
1-7/16"	SHC303651	SHC553651	SHC753651	SHC1103651
1-1/2"	SHC303810	SHC553810	SHC753810	SHC1103810
1-9/16"	SHC303969	SHC553969	SHC753969	SHC1103969
1-5/8"	SHC304128	SHC554128	SHC754128	SHC1104128
1-11/16"	SHC304286	SHC554286	SHC754286	SHC1104286
1-3/4"	SHC304445	SHC554445	SHC754445	SHC1104445
1-13/16"	SHC304604	SHC554604	SHC754604	SHC1104604
1-7/8"	SHC304763	SHC554763	SHC754763	SHC1104763
1-15/16"	SHC304921	SHC554921	SHC754921	SHC1104921
2"	SHC305080	SHC555080	SHC755080	SHC1105080
2-1/16"	SHC305239	SHC555239	—	—
2-1/8"	SHC305398	SHC555398	—	—
2-3/16"	SHC305556	SHC555556	—	—
2-1/4"	SHC305715	SHC555715	—	—
2-5/16"	SHC305874	SHC555874	—	—
2-3/8"	SHC306033	SHC556033	—	—
2-7/16"	SHC306191	SHC556191	—	—
2-1/2"	SHC306350	SHC556350	—	—
2-9/16"	SHC306509	SHC556509	—	—
2-5/8"	SHC306668	SHC556668	—	—
2-3/4"	SHC306985	SHC556985	—	—



DIA.	SHC30 TYPE	SHC55 TYPE	SHC75 TYPE	SHC110 TYPE
Drilling depth	30mm	55mm	75mm	110mm
Effective length	35mm	60mm	80mm	115mm
12mm	SHC30120	SHC55120	—	—
13mm	SHC30130	SHC55130	—	—
14mm	SHC30140	SHC55140	—	—
15mm	SHC30150	SHC55150	—	—
16mm	SHC30160	SHC55160	—	—
17mm	SHC30170	SHC55170	—	—
18mm	SHC30180	SHC55180	—	—
19mm	SHC30190	SHC55190	—	SHC110190
20mm	SHC30200	SHC55200	SHC75200	SHC110200
21mm	SHC30210	SHC55210	SHC75210	SHC110210
22mm	SHC30220	SHC55220	SHC75220	SHC110220
23mm	SHC30230	SHC55230	SHC75230	SHC110230
24mm	SHC30240	SHC55240	SHC75240	SHC110240
25mm	SHC30250	SHC55250	SHC75250	SHC110250
26mm	SHC30260	SHC55260	SHC75260	SHC110260
27mm	SHC30270	SHC55270	SHC75270	SHC110270
28mm	SHC30280	SHC55280	SHC75280	SHC110280
29mm	SHC30290	SHC55290	SHC75290	SHC110290
30mm	SHC30300	SHC55300	SHC75300	SHC110300
31mm	SHC30310	SHC55310	SHC75310	SHC110310
32mm	SHC30320	SHC55320	SHC75320	SHC110320
33mm	SHC30330	SHC55330	SHC75330	SHC110330
34mm	SHC30340	SHC55340	SHC75340	SHC110340
35mm	SHC30350	SHC55350	SHC75350	SHC110350
36mm	SHC30360	SHC55360	SHC75360	SHC110360
37mm	SHC30370	SHC55370	SHC75370	SHC110370
38mm	SHC30380	SHC55380	SHC75380	SHC110380
39mm	SHC30390	SHC55390	SHC75390	SHC110390
40mm	SHC30400	SHC55400	SHC75400	SHC110400
41mm	SHC30410	SHC55410	SHC75410	SHC110410
42mm	SHC30420	SHC55420	SHC75420	SHC110420
43mm	SHC30430	SHC55430	SHC75430	SHC110430
44mm	SHC30440	SHC55440	SHC75440	SHC110440
45mm	SHC30450	SHC55450	SHC75450	SHC110450
46mm	SHC30460	SHC55460	SHC75460	SHC110460
47mm	SHC30470	SHC55470	SHC75470	SHC110470
48mm	SHC30480	SHC55480	SHC75480	SHC110480
49mm	SHC30490	SHC55490	SHC75490	SHC110490
50mm	SHC30500	SHC55500	SHC75500	SHC110500
51mm	SHC30510	SHC55510	—	—
52mm	SHC30520	SHC55520	—	—
53mm	SHC30530	SHC55530	—	—
54mm	SHC30540	SHC55540	—	—
55mm	SHC30550	SHC55550	—	SHC110550
56mm	SHC30560	SHC55560	—	—
57mm	SHC30570	SHC55570	—	—
58mm	SHC30580	SHC55580	—	—
59mm	SHC30590	SHC55590	—	—
60mm	SHC30600	SHC55600	—	—
61mm	SHC30610	SHC55610	—	—
62mm	SHC30620	SHC55620	—	—
63mm	SHC30630	SHC55630	—	—
64mm	SHC30640	SHC55640	—	—
65mm	SHC30650	SHC55650	—	—
66mm	SHC30660	SHC55660	—	—
67mm	SHC30670	SHC55670	—	—
68mm	SHC30680	SHC55680	—	—
69mm	SHC30690	SHC55690	—	—
70mm	SHC30700	SHC55700	—	—

SHC TIALN

SHAJENG HARDWARE CO., LTD

SHC STANDARD TIALN SERIES

- Material: M2 High Speed Steel
- Drilling depth: 30mm, 55mm, 75mm, 110mm
- Effective length: 35mm, 60mm, 80mm, 115mm
- Faster feed rates are reached with more cutting teeth.
- Can drill holes three times faster than traditional hole making tools.
- The cutting edges can be re-sharpened.
- For high precision metal sheet drilling.
- Produces smoother surface.
- TIALN coating can increase the tool life.



HEAVY-DUTY
Ø 12mm ~ Ø 70mm

APPLICATIONS



HEAVY-DUTY

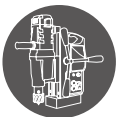

MAGNETIC DRILLING MACHINE



METAL SHEETS SUS304



METAL SHEETS SS41





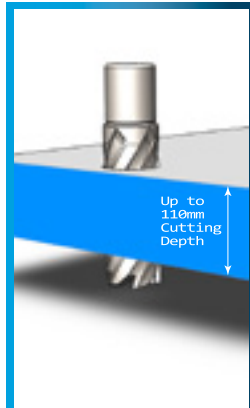





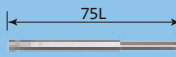

ALUMINUM

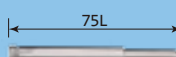

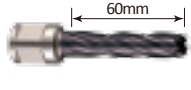
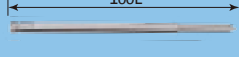
Up to 110mm Cutting Depth
IDEAL FOR DRILLING METAL SHEET

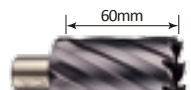
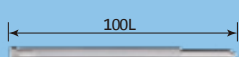
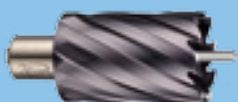
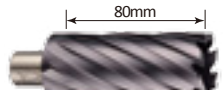
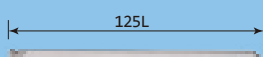

(See page 92 for more cutter's application)

	TYPE		PIN		
SHC30 M2 ITEM NO.	 35mm φ12mm~13mm / φ1/2"	+	 75L SHC30475P φ4.74mm×φ3.6mm×75L	=	SHC30 M2 TIA 
SHC30 M2 ITEM NO.	 35mm φ14mm~70mm / φ9/16"~2~3/4"	+	 75L SHC30675P φ6.34mm×φ4.8mm×75L	=	SHC30 M2 TIA 
SHC55 M2 ITEM NO.	 60mm φ12mm~13mm / φ1/2"	+	 100L SHC554100P φ4.74mm×φ3.6mm×100L	=	SHC55 M2 TIA 
SHC55 M2 ITEM NO.	 60mm φ14mm~70mm / φ9/16"~2~3/4"	+	 100L SHC556100P φ6.34mm×φ4.8mm×100L	=	SHC55 M2 TIA 
SHC75 M2 ITEM NO.	 80mm φ20mm~50mm / φ13/16"~2"	+	 125L SHC756125P φ6.34mm×125L	=	SHC75 M2 TIA 
SHC110 M2 ITEM NO.	 115mm φ20mm~50mm / φ13/16"~2"	+	 150L SHC1106150P φ6.34mm×150L	=	SHC110 M2 TIA 



SHC TIALN

SHAJENG HARDWARE CO., LTD



DIA.	SHC30 TYPE TIA	SHC55 TYPE TIA	SHC75 TYPE TIA	SHC110 TYPE TIA
Drilling depth	30mm	55mm	75mm	110mm
Effective length	35mm	60mm	80mm	115mm
1/2"	SHC301270TIA	SHC551270TIA	—	—
9/16"	SHC301429TIA	SHC551429TIA	—	—
5/8"	SHC301588TIA	SHC551588TIA	—	—
11/16"	SHC301746TIA	SHC551746TIA	—	—
3/4"	SHC301905TIA	SHC551905TIA	—	—
13/16"	SHC302064TIA	SHC552064TIA	SHC752064TIA	SHC1102064TIA
7/8"	SHC302223TIA	SHC552223TIA	SHC752223TIA	SHC1102223TIA
15/16"	SHC302381TIA	SHC552381TIA	SHC752381TIA	SHC1102381TIA
1"	SHC302540TIA	SHC552540TIA	SHC752540TIA	SHC1102540TIA
1-1/16"	SHC302699TIA	SHC552699TIA	SHC752699TIA	SHC1102699TIA
1-1/8"	SHC302858TIA	SHC552858TIA	SHC752858TIA	SHC1102858TIA
1-3/16"	SHC303016TIA	SHC553016TIA	SHC753016TIA	SHC1103016TIA
1-1/4"	SHC303175TIA	SHC553175TIA	SHC753175TIA	SHC1103175TIA
1-5/16"	SHC303334TIA	SHC553334TIA	SHC753334TIA	SHC1103334TIA
1-3/8"	SHC303493TIA	SHC553493TIA	SHC753493TIA	SHC1103493TIA
1-7/16"	SHC303651TIA	SHC553651TIA	SHC753651TIA	SHC1103651TIA
1-1/2"	SHC303810TIA	SHC553810TIA	SHC753810TIA	SHC1103810TIA
1-9/16"	SHC303969TIA	SHC553969TIA	SHC753969TIA	SHC1103969TIA
1-5/8"	SHC304128TIA	SHC554128TIA	SHC754128TIA	SHC1104128TIA
1-11/16"	SHC304286TIA	SHC554286TIA	SHC754286TIA	SHC1104286TIA
1-3/4"	SHC304445TIA	SHC554445TIA	SHC754445TIA	SHC1104445TIA
1-13/16"	SHC304604TIA	SHC554604TIA	SHC754604TIA	SHC1104604TIA
1-7/8"	SHC304763TIA	SHC554763TIA	SHC754763TIA	SHC1104763TIA
1-15/16"	SHC304921TIA	SHC554921TIA	SHC754921TIA	SHC1104921TIA
2"	SHC305080TIA	SHC555080TIA	SHC755080TIA	SHC1105080TIA
2-1/16"	SHC305239TIA	SHC555239TIA	—	—
2-1/8"	SHC305398TIA	SHC555398TIA	—	—
2-3/16"	SHC305556TIA	SHC555556TIA	—	—
2-1/4"	SHC305715TIA	SHC555715TIA	—	—
2-5/16"	SHC305874TIA	SHC555874TIA	—	—
2-3/8"	SHC306033TIA	SHC556033TIA	—	—
2-7/16"	SHC306191TIA	SHC556191TIA	—	—
2-1/2"	SHC306350TIA	SHC556350TIA	—	—
2-9/16"	SHC306509TIA	SHC556509TIA	—	—
2-5/8"	SHC306668TIA	SHC556668TIA	—	—
2-3/4"	SHC306985TIA	SHC556985TIA	—	—



DIA.	SHC30 TYPE TIA	SHC55 TYPE TIA	SHC75 TYPE TIA	SHC110 TYPE TIA
Drilling depth	30mm	55mm	75mm	110mm
Effective length	35mm	60mm	80mm	115mm
12mm	SHC30120TIA	SHC55120TIA	—	—
13mm	SHC30130TIA	SHC55130TIA	—	—
14mm	SHC30140TIA	SHC55140TIA	—	—
15mm	SHC30150TIA	SHC55150TIA	—	—
16mm	SHC30160TIA	SHC55160TIA	—	—
17mm	SHC30170TIA	SHC55170TIA	—	—
18mm	SHC30180TIA	SHC55180TIA	—	—
19mm	SHC30190TIA	SHC55190TIA	—	—
20mm	SHC30200TIA	SHC55200TIA	SHC75200TIA	SHC110200TIA
21mm	SHC30210TIA	SHC55210TIA	SHC75210TIA	SHC110210TIA
22mm	SHC30220TIA	SHC55220TIA	SHC75220TIA	SHC110220TIA
23mm	SHC30230TIA	SHC55230TIA	SHC75230TIA	SHC110230TIA
24mm	SHC30240TIA	SHC55240TIA	SHC75240TIA	SHC110240TIA
25mm	SHC30250TIA	SHC55250TIA	SHC75250TIA	SHC110250TIA
26mm	SHC30260TIA	SHC55260TIA	SHC75260TIA	SHC110260TIA
27mm	SHC30270TIA	SHC55270TIA	SHC75270TIA	SHC110270TIA
28mm	SHC30280TIA	SHC55280TIA	SHC75280TIA	SHC110280TIA
29mm	SHC30290TIA	SHC55290TIA	SHC75290TIA	SHC110290TIA
30mm	SHC30300TIA	SHC55300TIA	SHC75300TIA	SHC110300TIA
31mm	SHC30310TIA	SHC55310TIA	SHC75310TIA	SHC110310TIA
32mm	SHC30320TIA	SHC55320TIA	SHC75320TIA	SHC110320TIA
33mm	SHC30330TIA	SHC55330TIA	SHC75330TIA	SHC110330TIA
34mm	SHC30340TIA	SHC55340TIA	SHC75340TIA	SHC110340TIA
35mm	SHC30350TIA	SHC55350TIA	SHC75350TIA	SHC110350TIA
36mm	SHC30360TIA	SHC55360TIA	SHC75360TIA	SHC110360TIA
37mm	SHC30370TIA	SHC55370TIA	SHC75370TIA	SHC110370TIA
38mm	SHC30380TIA	SHC55380TIA	SHC75380TIA	SHC110380TIA
39mm	SHC30390TIA	SHC55390TIA	SHC75390TIA	SHC110390TIA
40mm	SHC30400TIA	SHC55400TIA	SHC75400TIA	SHC110400TIA
41mm	SHC30410TIA	SHC55410TIA	SHC75410TIA	SHC110410TIA
42mm	SHC30420TIA	SHC55420TIA	SHC75420TIA	SHC110420TIA
43mm	SHC30430TIA	SHC55430TIA	SHC75430TIA	SHC110430TIA
44mm	SHC30440TIA	SHC55440TIA	SHC75440TIA	SHC110440TIA
45mm	SHC30450TIA	SHC55450TIA	SHC75450TIA	SHC110450TIA
46mm	SHC30460TIA	SHC55460TIA	SHC75460TIA	SHC110460TIA
47mm	SHC30470TIA	SHC55470TIA	SHC75470TIA	SHC110470TIA
48mm	SHC30480TIA	SHC55480TIA	SHC75480TIA	SHC110480TIA
49mm	SHC30490TIA	SHC55490TIA	SHC75490TIA	SHC110490TIA
50mm	SHC30500TIA	SHC55500TIA	SHC75500TIA	SHC110500TIA
51mm	SHC30510TIA	SHC55510TIA	—	—
52mm	SHC30520TIA	SHC55520TIA	—	—
53mm	SHC30530TIA	SHC55530TIA	—	—
54mm	SHC30540TIA	SHC55540TIA	—	—
55mm	SHC30550TIA	SHC55550TIA	—	—
56mm	SHC30560TIA	SHC55560TIA	—	—
57mm	SHC30570TIA	SHC55570TIA	—	—
58mm	SHC30580TIA	SHC55580TIA	—	—
59mm	SHC30590TIA	SHC55590TIA	—	—
60mm	SHC30600TIA	SHC55600TIA	—	—
61mm	SHC30610TIA	SHC55610TIA	—	—
62mm	SHC30620TIA	SHC55620TIA	—	—
63mm	SHC30630TIA	SHC55630TIA	—	—
64mm	SHC30640TIA	SHC55640TIA	—	—
65mm	SHC30650TIA	SHC55650TIA	—	—
66mm	SHC30660TIA	SHC55660TIA	—	—
67mm	SHC30670TIA	SHC55670TIA	—	—
68mm	SHC30680TIA	SHC55680TIA	—	—
69mm	SHC30690TIA	SHC55690TIA	—	—
70mm	SHC30700TIA	SHC55700TIA	—	—

SHCO COBALT SERIES

- Material: M42 High Speed Steel
- Drilling depth: 30mm, 55mm, 75mm, 110mm
- Effective length: 35mm, 60mm, 80mm, 115mm
- Faster feed rates are reached with more cutting teeth.
- Can drill holes three times faster than traditional hole making tools.
- The cutting edges can be re-sharpened.
- For high precision metal sheet drilling.
- Produces smoother surface.

HIGH PERFORMANCE HEAVY-DUTY
Ø 12mm ~ Ø 70mm

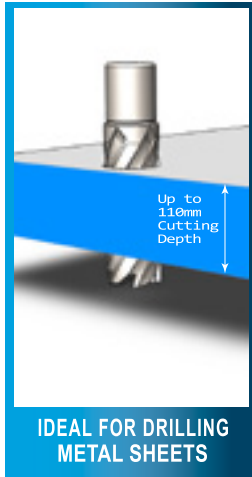

APPLICATIONS

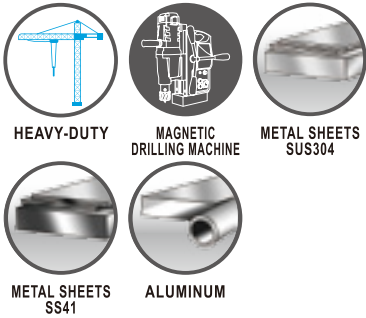

(See page 92 for more cutter's application)

TYPE		PIN		▶▶▶	
SHC030 M42	35mm φ12mm~13mm / φ1/2"	+	75L SHC30475P φ4.74mm×φ3.6mm×75L	=	SHCO30 M42
SHC030 M42	35mm φ14mm~70mm / φ9/16"~2~3/4"	+	75L SHC30675P φ6.34mm×φ4.8mm×75L	=	SHCO30 M42
SHC055 M42	60mm φ12mm~13mm / φ1/2"	+	100L SHC554100P φ4.74mm×φ3.6mm×100L	=	SHCO55 M42
SHC055 M42	60mm φ14mm~70mm / φ9/16"~2~3/4"	+	100L SHC556100P φ6.34mm×φ4.8mm×100L	=	SHCO55 M42
SHC075 M42	80mm φ20mm~50mm / φ13/16"~2"	+	125L SHC756125P φ6.34mm×125L	=	SHCO75 M42
SHC0110 M42	115mm φ20mm~50mm / φ13/16"~2"	+	150L SHC1106150P φ6.34mm×150L	=	SHCO110 M42

DIA.	SHCO30 TYPE M42	SHCO55 TYPE M42	SHCO75 TYPE M42	SHCO110 TYPE M42
Drilling depth	30mm	55mm	75mm	110mm
Effective length	35mm	60mm	80mm	115mm
1/2"	SHCO301270M42	SHCO551270M42	—	—
9/16"	SHCO301429M42	SHCO551429M42	—	—
5/8"	SHCO301588M42	SHCO551588M42	—	—
11/16"	SHCO301746M42	SHCO551746M42	—	—
3/4"	SHCO301905M42	SHCO551905M42	—	—
13/16"	SHCO302064M42	SHCO552064M42	SHCO752064M42	SHCO1102064M42
7/8"	SHCO302223M42	SHCO552223M42	SHCO752223M42	SHCO1102223M42
15/16"	SHCO302381M42	SHCO552381M42	SHCO752381M42	SHCO1102381M42
1"	SHCO302540M42	SHCO552540M42	SHCO752540M42	SHCO1102540M42
1-1/16"	SHCO302699M42	SHCO552699M42	SHCO752699M42	SHCO1102699M42
1-1/8"	SHCO302858M42	SHCO552858M42	SHCO752858M42	SHCO1102858M42
1-3/16"	SHCO303016M42	SHCO553016M42	SHCO753016M42	SHCO1103016M42
1-1/4"	SHCO303175M42	SHCO553175M42	SHCO753175M42	SHCO1103175M42
1-5/16"	SHCO303334M42	SHCO553334M42	SHCO753334M42	SHCO1103334M42
1-3/8"	SHCO303493M42	SHCO553493M42	SHCO753493M42	SHCO1103493M42
1-7/16"	SHCO303651M42	SHCO553651M42	SHCO753651M42	SHCO1103651M42
1-1/2"	SHCO303810M42	SHCO553810M42	SHCO753810M42	SHCO1103810M42
1-9/16"	SHCO303969M42	SHCO553969M42	SHCO753969M42	SHCO1103969M42
1-5/8"	SHCO304128M42	SHCO554128M42	SHCO754128M42	SHCO1104128M42
1-11/16"	SHCO304286M42	SHCO554286M42	SHCO754286M42	SHCO1104286M42
1-3/4"	SHCO304445M42	SHCO554445M42	SHCO754445M42	SHCO1104445M42
1-13/16"	SHCO304604M42	SHCO554604M42	SHCO754604M42	SHCO1104604M42
1-7/8"	SHCO304763M42	SHCO554763M42	SHCO754763M42	SHCO1104763M42
1-15/16"	SHCO304921M42	SHCO554921M42	SHCO754921M42	SHCO1104921M42
2"	SHCO305080M42	SHCO555080M42	SHCO755080M42	SHCO1105080M42
2-1/16"	SHCO305239M42	SHCO555239M42		
2-1/8"	SHCO305398M42	SHCO555398M42		
2-3/16"	SHCO305556M42	SHCO555556M42		
2-1/4"	SHCO305715M42	SHCO555715M42		
2-5/16"	SHCO305874M42	SHCO555874M42		
2-3/8"	SHCO306033M42	SHCO556033M42		
2-7/16"	SHCO306191M42	SHCO556191M42		
2-1/2"	SHCO306350M42	SHCO556350M42		
2-9/16"	SHCO306509M42	SHCO556509M42		
2-5/8"	SHCO306668M42	SHCO556668M42		
2-3/4"	SHCO306985M42	SHCO556985M42		





SHCO SERIES

SHAJENG HARDWARE CO., LTD

DIA.	SHCO30 TYPE M42	SHCO55 TYPE M42	SHCO75 TYPE M42	SHCO110 TYPE M42
Drilling depth	30mm	55mm	75mm	110mm
Effective length	35mm	60mm	80mm	115mm
12mm	SHCO30120M42	SHCO55120M42	—	—
13mm	SHCO30130M42	SHCO55130M42	—	—
14mm	SHCO30140M42	SHCO55140M42	—	—
15mm	SHCO30150M42	SHCO55150M42	—	—
16mm	SHCO30160M42	SHCO55160M42	—	—
17mm	SHCO30170M42	SHCO55170M42	—	—
18mm	SHCO30180M42	SHCO55180M42	—	—
19mm	SHCO30190M42	SHCO55190M42	—	—
20mm	SHCO30200M42	SHCO55200M42	SHCO75200M42	SHCO110200M42
21mm	SHCO30210M42	SHCO55210M42	SHCO75210M42	SHCO110210M42
22mm	SHCO30220M42	SHCO55220M42	SHCO75220M42	SHCO110220M42
23mm	SHCO30230M42	SHCO55230M42	SHCO75230M42	SHCO110230M42
24mm	SHCO30240M42	SHCO55240M42	SHCO75240M42	SHCO110240M42
25mm	SHCO30250M42	SHCO55250M42	SHCO75250M42	SHCO110250M42
26mm	SHCO30260M42	SHCO55260M42	SHCO75260M42	SHCO110260M42
27mm	SHCO30270M42	SHCO55270M42	SHCO75270M42	SHCO110270M42
28mm	SHCO30280M42	SHCO55280M42	SHCO75280M42	SHCO110280M42
29mm	SHCO30290M42	SHCO55290M42	SHCO75290M42	SHCO110290M42
30mm	SHCO30300M42	SHCO55300M42	SHCO75300M42	SHCO110300M42
31mm	SHCO30310M42	SHCO55310M42	SHCO75310M42	SHCO110310M42
32mm	SHCO30320M42	SHCO55320M42	SHCO75320M42	SHCO110320M42
33mm	SHCO30330M42	SHCO55330M42	SHCO75330M42	SHCO110330M42
34mm	SHCO30340M42	SHCO55340M42	SHCO75340M42	SHCO110340M42
35mm	SHCO30350M42	SHCO55350M42	SHCO75350M42	SHCO110350M42
36mm	SHCO30360M42	SHCO55360M42	SHCO75360M42	SHCO110360M42
37mm	SHCO30370M42	SHCO55370M42	SHCO75370M42	SHCO110370M42
38mm	SHCO30380M42	SHCO55380M42	SHCO75380M42	SHCO110380M42
39mm	SHCO30390M42	SHCO55390M42	SHCO75390M42	SHCO110390M42
40mm	SHCO30400M42	SHCO55400M42	SHCO75400M42	SHCO110400M42
41mm	SHCO30410M42	SHCO55410M42	SHCO75410M42	SHCO110410M42
42mm	SHCO30420M42	SHCO55420M42	SHCO75420M42	SHCO110420M42
43mm	SHCO30430M42	SHCO55430M42	SHCO75430M42	SHCO110430M42
44mm	SHCO30440M42	SHCO55440M42	SHCO75440M42	SHCO110440M42
45mm	SHCO30450M42	SHCO55450M42	SHCO75450M42	SHCO110450M42
46mm	SHCO30460M42	SHCO55460M42	SHCO75460M42	SHCO110460M42
47mm	SHCO30470M42	SHCO55470M42	SHCO75470M42	SHCO110470M42
48mm	SHCO30480M42	SHCO55480M42	SHCO75480M42	SHCO110480M42
49mm	SHCO30490M42	SHCO55490M42	SHCO75490M42	SHCO110490M42
50mm	SHCO30500M42	SHCO55500M42	SHCO75500M42	SHCO110500M42
51mm	SHCO30510M42	SHCO55510M42	—	—
52mm	SHCO30520M42	SHCO55520M42	—	—
53mm	SHCO30530M42	SHCO55530M42	—	—
54mm	SHCO30540M42	SHCO55540M42	—	—
55mm	SHCO30550M42	SHCO55550M42	—	—
56mm	SHCO30560M42	SHCO55560M42	—	—
57mm	SHCO30570M42	SHCO55570M42	—	—
58mm	SHCO30580M42	SHCO55580M42	—	—
59mm	SHCO30590M42	SHCO55590M42	—	—
60mm	SHCO30600M42	SHCO55600M42	—	—
61mm	SHCO30610M42	SHCO55610M42	—	—
62mm	SHCO30620M42	SHCO55620M42	—	—
63mm	SHCO30630M42	SHCO55630M42	—	—
64mm	SHCO30640M42	SHCO55640M42	—	—
65mm	SHCO30650M42	SHCO55650M42	—	—
66mm	SHCO30660M42	SHCO55660M42	—	—
67mm	SHCO30670M42	SHCO55670M42	—	—
68mm	SHCO30680M42	SHCO55680M42	—	—
69mm	SHCO30690M42	SHCO55690M42	—	—
70mm	SHCO30700M42	SHCO55700M42	—	—

SHCO COBALT TIALN SERIES

- Material: M42 High Speed Steel
- Drilling depth: 30mm, 55mm, 75mm, 110mm
- Effective length: 35mm, 60mm, 80mm, 115mm
- Faster feed rates are reached with more cutting teeth.
- Can drill holes three times faster than traditional hole making tools.
- The cutting edges can be re-sharpened.
- For high precision metal sheet drilling.
- Produces smoother surface.
- TIALN coating can increase the tool life.



HEAVY-DUTY
φ 12mm ~ φ 70mm

APPLICATIONS



HEAVY-DUTY

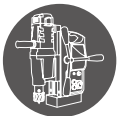

MAGNETIC DRILLING MACHINE



METAL SHEETS SUS304









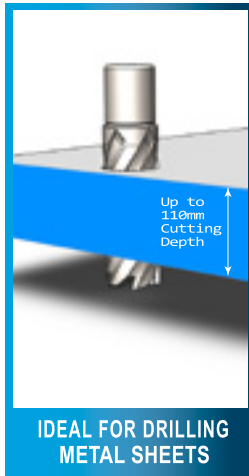

METAL SHEETS SS41

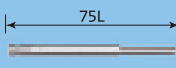

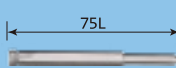
ALUMINUM

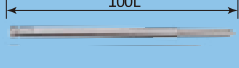
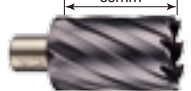
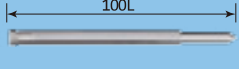

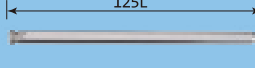
HSS HOLE CUTTER / SHCO TIALN SERIES

	TYPE		PIN	
SHCO30 M42	 φ12mm~13mm / φ1/2"	+	 SHC30475P φ4.74mm×φ3.6mm×75L	=
ITEM NO.				SHCO30 M42 TIA
SHCO30 M42	 φ14mm~70mm / φ9/16"~2~3/4"	+	 SHC30675P φ6.34mm×φ4.8mm×75L	=
ITEM NO.				SHCO30 M42 TIA
SHCO55 M42	 φ12mm~13mm / φ1/2"	+	 SHC554100P φ4.74mm×φ3.6mm×100L	=
ITEM NO.				SHCO55 M42 TIA
SHCO55 M42	 φ14mm~70mm / φ9/16"~2~3/4"	+	 SHC556100P φ6.34mm×φ4.8mm×100L	=
ITEM NO.				SHCO55 M42 TIA
SHCO75 M42	 φ20mm~50mm / φ13/16"~2"	+	 SHC756125P φ6.34mm×125L	=
ITEM NO.				SHCO75 M42 TIA
SHCO110 M42	 φ20mm~50mm / φ13/16"~2"	+	 SHC1106150P φ6.34mm×150L	=
ITEM NO.				SHCO110 M42 TIA

HSS HOLE CUTTER

SHC STANDARD/SHC TIALN/SHCO SERIES/SHCO TIALN



SHCO TIALN

SHAJENG HARDWARE CO., LTD

DIA.	SHCO30 TYPE M42 IN TIA	SHCO55 TYPE M42 IN TIA	SHCO75 TYPE M42 IN TIA	SHCO110 TYPE M42 IN TIA
Drilling depth	30mm	55mm	75mm	110mm
Effective length	35mm	60mm	80mm	115mm
1/2"	SHCO301270M42A	SHCO551270M42A	—	—
9/16"	SHCO301429M42A	SHCO551429M42A	—	—
5/8"	SHCO301588M42A	SHCO551588M42A	—	—
11/16"	SHCO301746M42A	SHCO551746M42A	—	—
3/4"	SHCO301905M42A	SHCO551905M42A	—	—
13/16"	SHCO302064M42A	SHCO552064M42A	SHCO752064M42A	SHCO1102064M42A
7/8"	SHCO302223M42A	SHCO552223M42A	SHCO752223M42A	SHCO1102223M42A
15/16"	SHCO302381M42A	SHCO552381M42A	SHCO752381M42A	SHCO1102381M42A
1"	SHCO302540M42A	SHCO552540M42A	SHCO752540M42A	SHCO1102540M42A
1-1/16"	SHCO302699M42A	SHCO552699M42A	SHCO752699M42A	SHCO1102699M42A
1-1/8"	SHCO302858M42A	SHCO552858M42A	SHCO752858M42A	SHCO1102858M42A
1-3/16"	SHCO303016M42A	SHCO553016M42A	SHCO753016M42A	SHCO1103016M42A
1-1/4"	SHCO303175M42A	SHCO553175M42A	SHCO753175M42A	SHCO1103175M42A
1-5/16"	SHCO303334M42A	SHCO553334M42A	SHCO753334M42A	SHCO1103334M42A
1-3/8"	SHCO303493M42A	SHCO553493M42A	SHCO753493M42A	SHCO1103493M42A
1-7/16"	SHCO303651M42A	SHCO553651M42A	SHCO753651M42A	SHCO1103651M42A
1-1/2"	SHCO303810M42A	SHCO553810M42A	SHCO753810M42A	SHCO1103810M42A
1-9/16"	SHCO303969M42A	SHCO553969M42A	SHCO753969M42A	SHCO1103969M42A
1-5/8"	SHCO304128M42A	SHCO554128M42A	SHCO754128M42A	SHCO1104128M42A
1-11/16"	SHCO304286M42A	SHCO554286M42A	SHCO754286M42A	SHCO1104286M42A
1-3/4"	SHCO304445M42A	SHCO554445M42A	SHCO754445M42A	SHCO1104445M42A
1-13/16"	SHCO304604M42A	SHCO554604M42A	SHCO754604M42A	SHCO1104604M42A
1-7/8"	SHCO304763M42A	SHCO554763M42A	SHCO754763M42A	SHCO1104763M42A
1-15/16"	SHCO304921M42A	SHCO554921M42A	SHCO754921M42A	SHCO1104921M42A
2"	SHCO305080M42A	SHCO555080M42A	SHCO755080M42A	SHCO1105080M42A
2-1/16"	SHCO305239M42A	SHCO555239M42A	—	—
2-1/8"	SHCO305398M42A	SHCO555398M42A	—	—
2-3/16"	SHCO305556M42A	SHCO555556M42A	—	—
2-1/4"	SHCO305715M42A	SHCO555715M42A	—	—
2-5/16"	SHCO305874M42A	SHCO555874M42A	—	—
2-3/8"	SHCO306033M42A	SHCO556033M42A	—	—
2-7/16"	SHCO306191M42A	SHCO556191M42A	—	—
2-1/2"	SHCO306350M42A	SHCO556350M42A	—	—
2-9/16"	SHCO306509M42A	SHCO556509M42A	—	—
2-5/8"	SHCO306668M42A	SHCO556668M42A	—	—
2-3/4"	SHCO306985M42A	SHCO556985M42A	—	—



DIA.	SHCO30 TYPE M42 IN TIA	SHCO55 TYPE M42 IN TIA	SHCO75 TYPE M42 IN TIA	SHCO110 TYPE M42 IN TIA
Drilling depth	30mm	55mm	75mm	110mm
Effective length	35mm	60mm	80mm	115mm
12mm	SHCO30120M42A	SHCO55120M42A	—	—
13mm	SHCO30130M42A	SHCO55130M42A	—	—
14mm	SHCO30140M42A	SHCO55140M42A	—	—
15mm	SHCO30150M42A	SHCO55150M42A	—	—
16mm	SHCO30160M42A	SHCO55160M42A	—	—
17mm	SHCO30170M42A	SHCO55170M42A	—	—
18mm	SHCO30180M42A	SHCO55180M42A	—	—
19mm	SHCO30190M42A	SHCO55190M42A	—	—
20mm	SHCO30200M42A	SHCO55200M42A	SHCO75200M42A	SHCO110200M42A
21mm	SHCO30210M42A	SHCO55210M42A	SHCO75210M42A	SHCO110210M42A
22mm	SHCO30220M42A	SHCO55220M42A	SHCO75220M42A	SHCO110220M42A
23mm	SHCO30230M42A	SHCO55230M42A	SHCO75230M42A	SHCO110230M42A
24mm	SHCO30240M42A	SHCO55240M42A	SHCO75240M42A	SHCO110240M42A
25mm	SHCO30250M42A	SHCO55250M42A	SHCO75250M42A	SHCO110250M42A
26mm	SHCO30260M42A	SHCO55260M42A	SHCO75260M42A	SHCO110260M42A
27mm	SHCO30270M42A	SHCO55270M42A	SHCO75270M42A	SHCO110270M42A
28mm	SHCO30280M42A	SHCO55280M42A	SHCO75280M42A	SHCO110280M42A
29mm	SHCO30290M42A	SHCO55290M42A	SHCO75290M42A	SHCO110290M42A
30mm	SHCO30300M42A	SHCO55300M42A	SHCO75300M42A	SHCO110300M42A
31mm	SHCO30310M42A	SHCO55310M42A	SHCO75310M42A	SHCO110310M42A
32mm	SHCO30320M42A	SHCO55320M42A	SHCO75320M42A	SHCO110320M42A
33mm	SHCO30330M42A	SHCO55330M42A	SHCO75330M42A	SHCO110330M42A
34mm	SHCO30340M42A	SHCO55340M42A	SHCO75340M42A	SHCO110340M42A
35mm	SHCO30350M42A	SHCO55350M42A	SHCO75350M42A	SHCO110350M42A
36mm	SHCO30360M42A	SHCO55360M42A	SHCO75360M42A	SHCO110360M42A
37mm	SHCO30370M42A	SHCO55370M42A	SHCO75370M42A	SHCO110370M42A
38mm	SHCO30380M42A	SHCO55380M42A	SHCO75380M42A	SHCO110380M42A
39mm	SHCO30390M42A	SHCO55390M42A	SHCO75390M42A	SHCO110390M42A
40mm	SHCO30400M42A	SHCO55400M42A	SHCO75400M42A	SHCO110400M42A
41mm	SHCO30410M42A	SHCO55410M42A	SHCO75410M42A	SHCO110410M42A
42mm	SHCO30420M42A	SHCO55420M42A	SHCO75420M42A	SHCO110420M42A
43mm	SHCO30430M42A	SHCO55430M42A	SHCO75430M42A	SHCO110430M42A
44mm	SHCO30440M42A	SHCO55440M42A	SHCO75440M42A	SHCO110440M42A
45mm	SHCO30450M42A	SHCO55450M42A	SHCO75450M42A	SHCO110450M42A
46mm	SHCO30460M42A	SHCO55460M42A	SHCO75460M42A	SHCO110460M42A
47mm	SHCO30470M42A	SHCO55470M42A	SHCO75470M42A	SHCO110470M42A
48mm	SHCO30480M42A	SHCO55480M42A	SHCO75480M42A	SHCO110480M42A
49mm	SHCO30490M42A	SHCO55490M42A	SHCO75490M42A	SHCO110490M42A
50mm	SHCO30500M42A	SHCO55500M42A	SHCO75500M42A	SHCO110500M42A
51mm	SHCO30510M42A	SHCO55510M42A	—	—
52mm	SHCO30520M42A	SHCO55520M42A	—	—
53mm	SHCO30530M42A	SHCO55530M42A	—	—
54mm	SHCO30540M42A	SHCO55540M42A	—	—
55mm	SHCO30550M42A	SHCO55550M42A	—	—
56mm	SHCO30560M42A	SHCO55560M42A	—	—
57mm	SHCO30570M42A	SHCO55570M42A	—	—
58mm	SHCO30580M42A	SHCO55580M42A	—	—
59mm	SHCO30590M42A	SHCO55590M42A	—	—
60mm	SHCO30600M42A	SHCO55600M42A	—	—
61mm	SHCO30610M42A	SHCO55610M42A	—	—
62mm	SHCO30620M42A	SHCO55620M42A	—	—
63mm	SHCO30630M42A	SHCO55630M42A	—	—
64mm	SHCO30640M42A	SHCO55640M42A	—	—
65mm	SHCO30650M42A	SHCO55650M42A	—	—
66mm	SHCO30660M42A	SHCO55660M42A	—	—
67mm	SHCO30670M42A	SHCO55670M42A	—	—
68mm	SHCO30680M42A	SHCO55680M42A	—	—
69mm	SHCO30690M42A	SHCO55690M42A	—	—
70mm	SHCO30700M42A	SHCO55700M42A	—	—



SHC SERIES SET

- SHC Hole Cutter kit has 6 pieces of Hole Cutter in different sizes.
- Select Hole Cutter ranging from 14mm to 26mm diameter.

SHC SET 1

SPECIFICATION

SHC Type	SHC30 Standard / SHCO30 Cobalt M42
Material	High Speed Steel
Drilling Depth	30mm
Effective Length	35mm
Minimum Hole Cutter Diameter(mm)	14mm
Maximum Hole Cutter Diameter(mm)	26mm
Kit Includes	(6) Hole Cutters; (2) Pilot Pins
Number of Pieces	8



SHC SET 2

SPECIFICATION

SHC Type	SHC55 Standard / SHCO55 Cobalt M42
Material	High Speed Steel
Drilling Depth	55mm
Effective Length	60mm
Minimum Hole Cutter Diameter(mm)	14
Maximum Hole Cutter Diameter(mm)	26
Kit Includes	(6) Hole Cutters; (2) Pilot Pins
Number of Pieces	8







ACCESSORY

- ADAPTER
- TOOL HOLDER
- TWIST DRILL
- EXTENSION
- CHUCK ADAPTER
- MAGNETIC CHIP COLLECTOR





ADAPTER

Designed to match any kinds of Magnetic Drill Machines.

DESCRIPTION	ITEM NO.
Fein shank to Weldon shank	AD32100F
Hitachi shank to Weldon shank	AD32200H
Nitto shank to Weldon shank	AD32300N
Alfra shank to Weldon shank	AD32400A
Weldon shank to Nitto shank	AD32500W
Nitto shank to M19 shank	AD32510N



ADAPTER TYPES

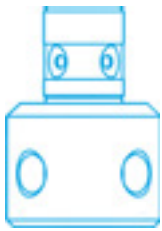

Fein Shank to Weldon



Hitachi Shank to Weldon



Nitto Shank to Weldon

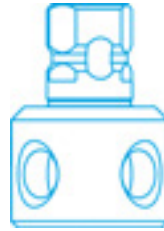

Alfra Shank to Weldon



Weldon Shank to Nitto



Nitto Shank to M19 Thread

MAGDRILL

ADAPTER

HOLE CUTTER

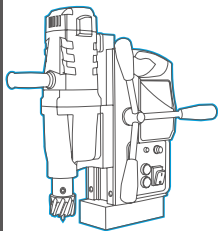

FEIN Quick-In 18mm → ← WELDON 19mm 3/4"

AD32100F

HITACHI /THREAD → ← WELDON 19mm 3/4"

AD32200H

NITTO 19mm → ← WELDON 19mm 3/4"

AD32300N

ALFRA 19mm → ← WELDON 19mm 3/4"

AD32400A

WELDON 19mm → ← NITTO 19mm 3/4"

AD32500W

NITTO 19mm → ← M18 /THREAD

AD32510N



▲ TCT HOLE CUTTER



▲ HSS HOLE CUTTER



TOOL HOLDER

- The spring-loaded shank of the cutter picks up the whole location quickly, and ejects the slug automatically at the end of the cut.
- Available with No.2, No.3 and No. 4 Morse taper shanks
- Applicable on Electric drill, Milling machine, Magnetic drill machine



SHANK OF HOLE CUTTER	LENGTH	APPLICATION	PART NO.	MORSE TAPER	DESCRIPTION
φ19.05	158mm	Up to 35mm thick	MT20350	2	with internal cooling
φ19.05	158mm	Up to 35mm thick	MT20350WT	2	without internal cooling
φ19.05	158mm	Up to 60mm thick	MT30600Q	2	quick change / with internal cooling
φ19.05	177mm	Up to 50mm thick	MT30500	3	with internal cooling
φ19.05	177mm	Up to 50mm thick	MT30500WT	3	without internal cooling
M18 x 1.5P		Up to 50mm thick	MT30500J	3	with internal cooling
φ19.05	210mm	Up to 75mm thick	MT30750	3	with internal cooling
φ19.05	266mm	Up to 110mm thick	MT301100	3	with internal cooling
φ31.75	255mm	Up to 75mm thick	MT30750L	3	with internal cooling
φ31.75	276mm	Up to 75mm thick	MT40750L	4	with internal cooling
φ31.75	229mm	Up to 75mm thick	MT30750LF	3	with internal cooling
φ31.75	250mm	Up to 75mm thick	MT40750LF	4	with internal cooling

TWIST DRILL

- Material: M2 High speed steel
- Allows quick change for drilling without removing arbor and coolant system.
- For small sizes only.

HEAVY-DUTY
 ϕ 6mm ~ ϕ 27.5mm

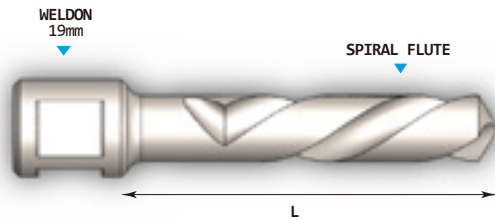
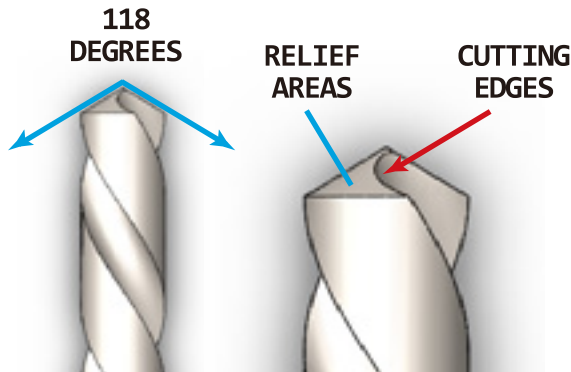

TD25 Type Twist Drill
 Material: M2
 Shank dia.: 3/4"
 Effective length: 73L

TD50 Type Twist Drill
 Material: M2
 Shank dia.: 3/4"
 Effective length: 96L

DIA.	ITEM NO.	ITEM NO.
1/4"	-	TD5020635
5/16"	-	TD5020794
3/8"	-	TD5020953
7/16"	-	TD5021111
1/2"	-	TD5021270
6mm	TD2520600	TD5020600
8mm	TD2520800	TD5020800
10mm	TD2521000	TD5021000
12mm	TD2521200	TD5021200
14mm	TD2521400	TD5021400
16mm	TD2521600	TD5021600
17mm	TD2521700	TD5021700
18mm	TD2521800	TD5021800
19mm	TD2521900	TD5021900
20mm	TD2522000	TD5022000
22mm	TD2522200	TD5022200
24mm	TD2522400	TD5022400
25mm	TD2522500	TD5022500
26mm	TD2522600	TD5022600
27.5mm	TD2522750	TD5022750

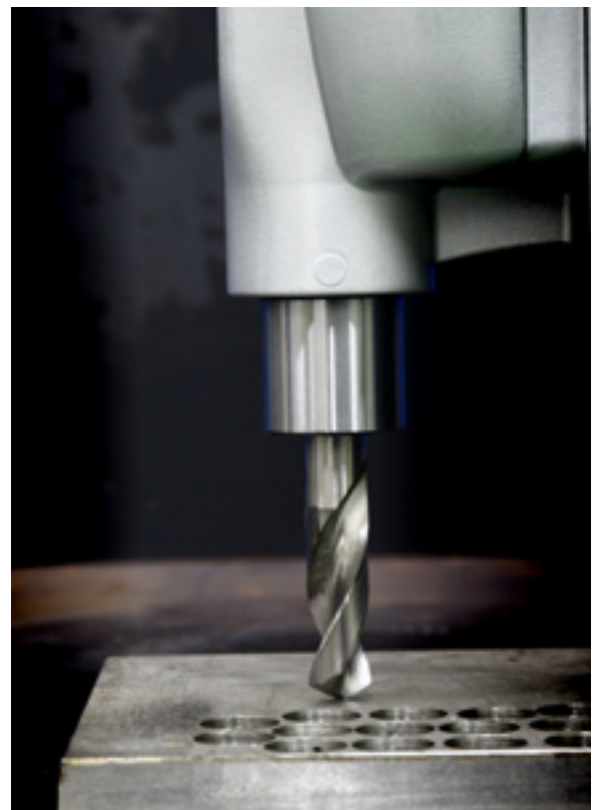

EXTENSION

- High quality extension arbor for improving access to deep drilling applications. Can be mounted in series for extreme depth applications.

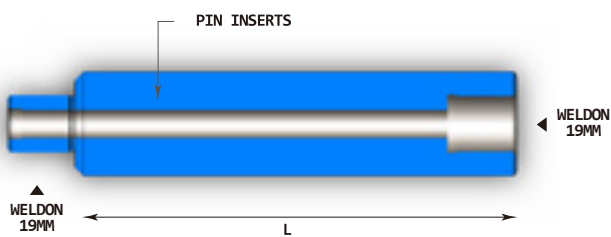

MAGDRILL	EXTENSION	HOLE CUTTER
	<p>ED10500</p>	<p>▲ TCT HOLE CUTTER</p>
	<p>ED10750</p>	
	<p>ED10100</p>	<p>▲ HSS HOLE CUTTER</p>
	<p>ED101500</p>	

ITEM NO.	SPECIFICATION
ED100500	50L
ED100750	75L
ED101000	100L
ED101500	150L
ED102000	200L
ED102500	250L





CHUCK ADAPTER

Description:

- Specially designed to match any weldon shank machines such as magnetic drill machines with weldon shank.

Application:

- Jaws specially designed to ensure high gripping.
- Jaws center ground for absolute straightness and alignment.

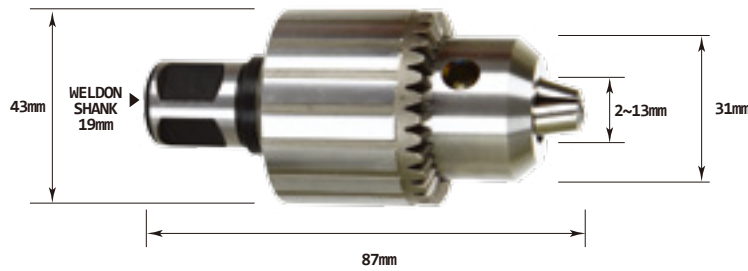

ITEM NO.	JAWS	SHANK	DIMENSION		
			L	SLEEVE DIA.	NOSE DIA.
B-400-CHUCK 1/2"	2 ~ 13mm	19mm Weldon	87mm	43mm	31mm

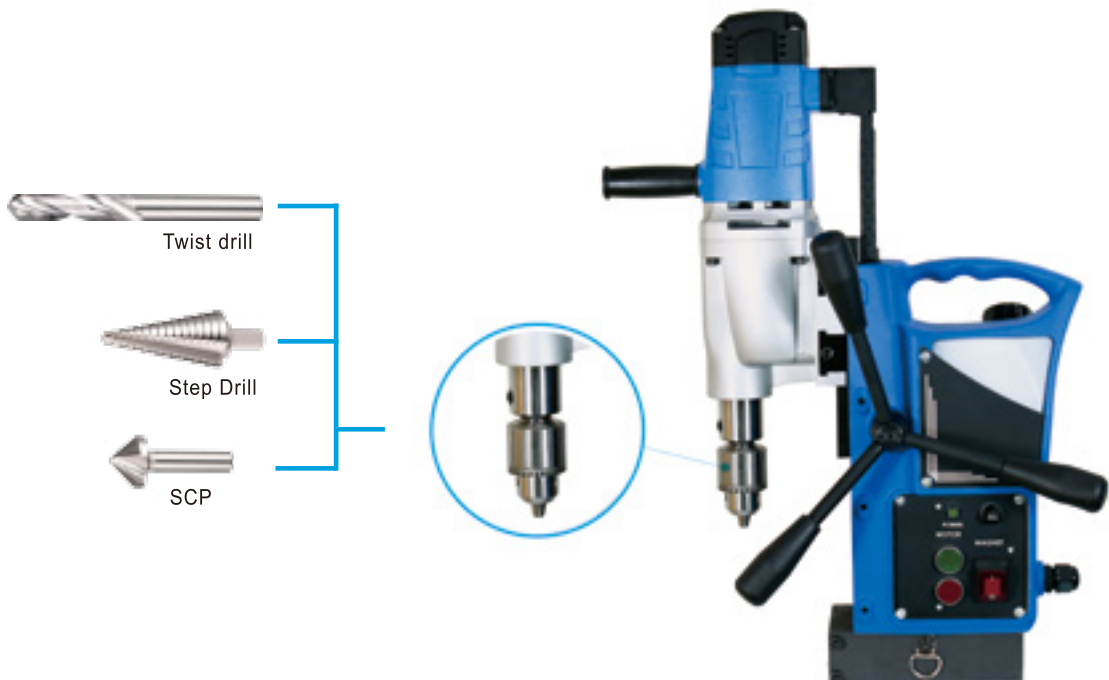

CHUCK ADAPTER

SHAJENG HARDWARE CO., LTD

MAGNETIC CHIP COLLECTOR

Description:

- Quick and easy removal or disposal of drilling swarf.

Application:

- Removes chips from drilled materials, grinding machines or lathes.
- Removes iron bits also from liquid, powder, grains easily.

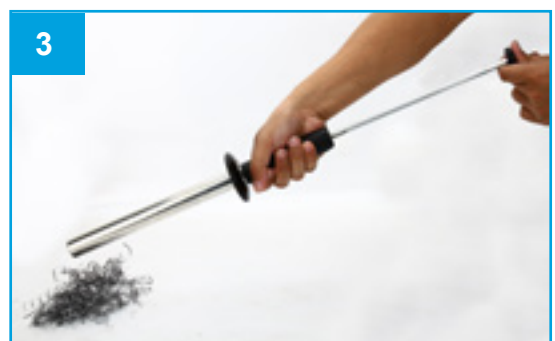
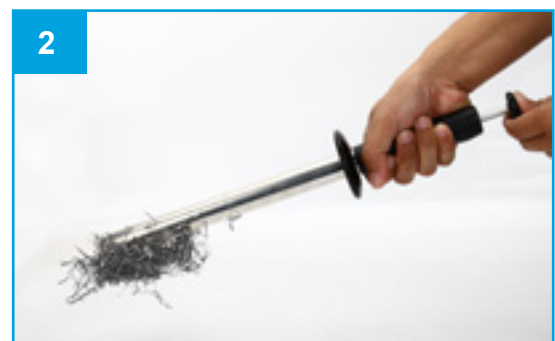
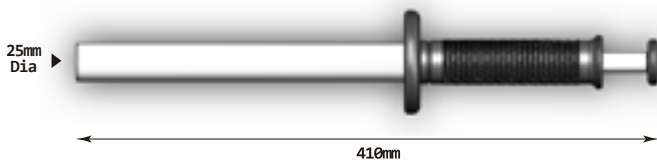
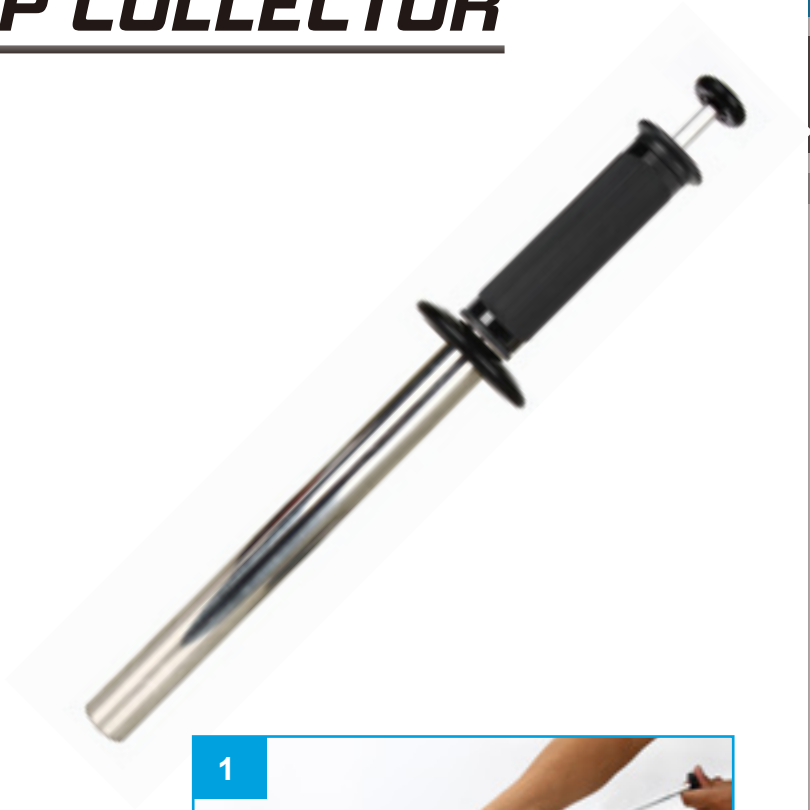

ITEM NO.	DIMENSION	
	DIA.	LENGTH
MK25410	25mm	410





STEP DRILL

All features in comparison.



		SDT	SDT TIN	SDR	SDR TIN	SDR TIALN
Application Guide						
	Metal Sheets SUS304	★★	★★	★★	★★	★★
	Metal Sheets SS41	★★★	★★★	★★★	★★★	★★★
	Steel Pipes SUS304	★★	★★	★★	★★	★★
	Steel Pipes SS41	★	★	★	★	★
	Cast Iron	★★★	★★★	★★★	★★★	★★★
	Aluminum	★★★	★★★	★★★	★★★	★★★
	Copper	★★★	★★★	★★★	★★★	★★★
	Bronze	★★★	★★★	★★★	★★★	★★★
	I-Beam	★★	★★	★★	★★	★★
	Fiber Glass	★★★	★★★	★★★	★★★	★★★



		SDT	SDT TIN	SDR	SDR TIN	SDR TIALN
Application Guide						
	L-Bar	★★★	★★★	★★★	★★★	★★★
	PVC Pipes	★★★	★★★	★★★	★★★	★★★
	Square pipe	★★★	★★★	★★★	★★★	★★★
	Wood	★★★	★★★	★★★	★★★	★★★
	Wood With Nails	★	★	★	★	★

★★★ : Excellent, ★★ : Good, ★ : Fair

ACCESSORIES / ALL FEATURES IN COMPARISON





SDT TYPE MULTI STEP DRILL

- Material: M2 High speed steel
- Single-fluted design for easier re-sharpening and greater control through steps
- Anti-skip tip eliminates the need for center punching or pilot hole drilling
- Can tolerate very high working temperature
- Can prevent the cutting edges from stoppage
- Much higher durability
- Tin coating allows Step drills to last longer than without.



HEAVY-DUTY
Up to 45 Steps

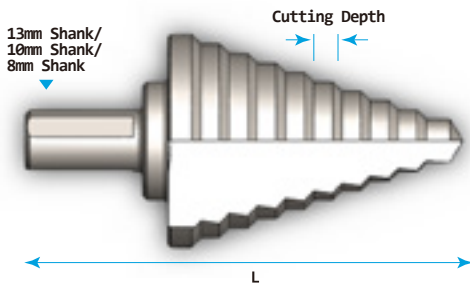

APPLICATIONS

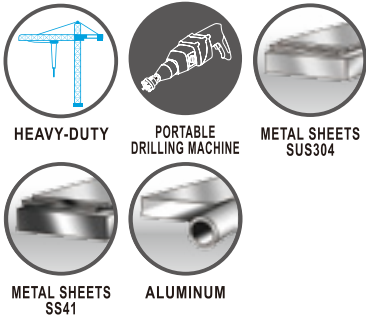

(See page 114 for more cutter's application)

The CBN ground flutes guarantee smooth running and high cutting performance.

STEPS (mm)	SHANK Ø D	L	SDT TYPE	SDT TYPE TIN COATED
4, 5, 6, 7, 8, 9, 10, 11, 12	φ8	70	SDT10412	SDT10412TIN
4, 6, 8, 10, 12, 14, 16, 18, 20	φ10	77	SDT10420	SDT10420TIN
4, 6, 8, 10, 12, 14, 16, 18, 20, 22, 24, 26	φ10	93	SDT10426	SDT10426TIN
3/16", 7/8"			SDT104822	SDT104822TIN
6, 8, 10, 12, 14, 16, 18	φ10		SDT10618	SDT10618TIN
6, 8, 10, 12, 14, 16, 18, 20, 22, 24, 26, 28, 30	φ10	98	SDT10630	SDT10630TIN
6, 9, 11, 13, 15, 17, 19, 21, 23, 25, 27, 29, 31, 33	φ10		SDT10633	SDT10633TIN
6, 8, 10, 12, 14, 16, 18, 20, 22, 24, 26, 28, 30, 32,34,36,38,40,42			SDT10642	SDT10642TIN
7, 11, 15, 19, 23, 27, 31, 35, 39, 43	φ13	93	SDT10743	SDT10743TIN
8, 10, 12, 14, 16, 18, 20, 22, 24, 26, 28, 30, 32, 34, 36, 38	φ13	113	SDT10838	SDT10838TIN
8, 12, 16, 20, 24, 28, 32, 36, 40, 44	φ13	93	SDT10844	SDT10844TIN
9, 13, 17, 21, 25, 29, 33, 37, 41, 45	φ13	93	SDT10945	SDT10945TIN



SDR TYPE SPIRAL STEP DRILL

- Material: M2 High speed steel
- For smooth and easy cuts
- The cutting edge of each step has a relief angle
- For high precision drilling
- Extreme wear resistance
- Tin and Tialn coating allows Step drills to last longer than without.**

APPLICATIONS



HEAVY-DUTY



PORTABLE DRILLING MACHINE



METAL SHEETS SUS304



METAL SHEETS SS41



ALUMINUM

(See page 114 for more cutter's application)

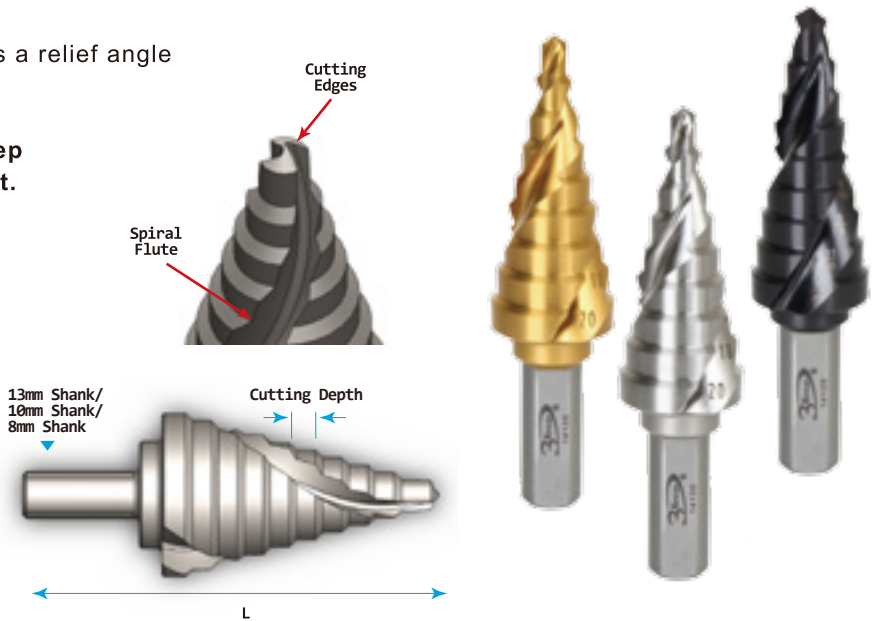

STEPS (mm)	SHANK Ø D	L	SDR TYPE	SDR TYPE TIN COATED	SDR TYPE TIA COATED
4, 5, 6, 7, 8, 9, 10, 11, 12	φ8	70	SDR10412	SDR10412TIN	SDR10412TIA
4, 6, 8, 10, 12, 14, 16, 18, 20	φ10	77	SDR10420	SDR10420TIN	SDR10420TIA
4, 6, 8, 10, 12, 14, 16, 18, 20, 22, 24, 26	φ10	93	SDR10426	SDR10426TIN	SDR10426TIA
3/16, 7/8"			SDR104822	SDR104822TIN	SDR104822TIA
6, 8, 10, 12, 14, 16, 18, 20, 22, 24, 26, 28, 30	φ10	98	SDR10630	SDR10630TIN	SDR10630TIA
7, 11, 15, 19, 23, 27, 31, 35, 39, 43	φ13	93	SDR10743	SDR10743TIN	SDR10743TIA
8, 10, 12, 14, 16, 18, 20, 22, 24, 26, 28, 30, 32, 34, 36, 38	φ13	113	SDR10838	SDR10838TIN	SDR10838TIA
8, 12, 16, 20, 24, 28, 32, 36, 40, 44	φ13	93	SDR10844	SDR10844TIN	SDR10844TIA
9, 13, 17, 21, 25, 29, 33, 37, 41, 45	φ13	93	SDR10945	SDR10945TIN	SDR10945TIA



COUNTERSINK

All features in comparison.

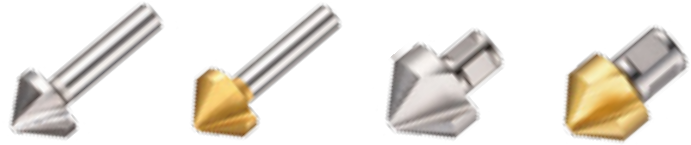

	SCP	SCP TIN	SCS	SCS TIN
Application Guide				
Metal Sheets SUS304	★★	★★	★★	★★
Metal Sheets SS41	★★★	★★★	★★★	★★★
Steel Pipes SUS304	★★	★★	★★	★★
Steel Pipes SS41	★★★	★★★	★★★	★★★
Cast Iron	★★★	★★★	★★★	★★★
Aluminum	★★★	★★★	★★★	★★★
Copper	★★★	★★★	★★★	★★★
Bronze	★★★	★★★	★★★	★★★
I-Beam	★★★	★★★	★★★	★★★
Fiber Glass	★★★	★★★	★★★	★★★

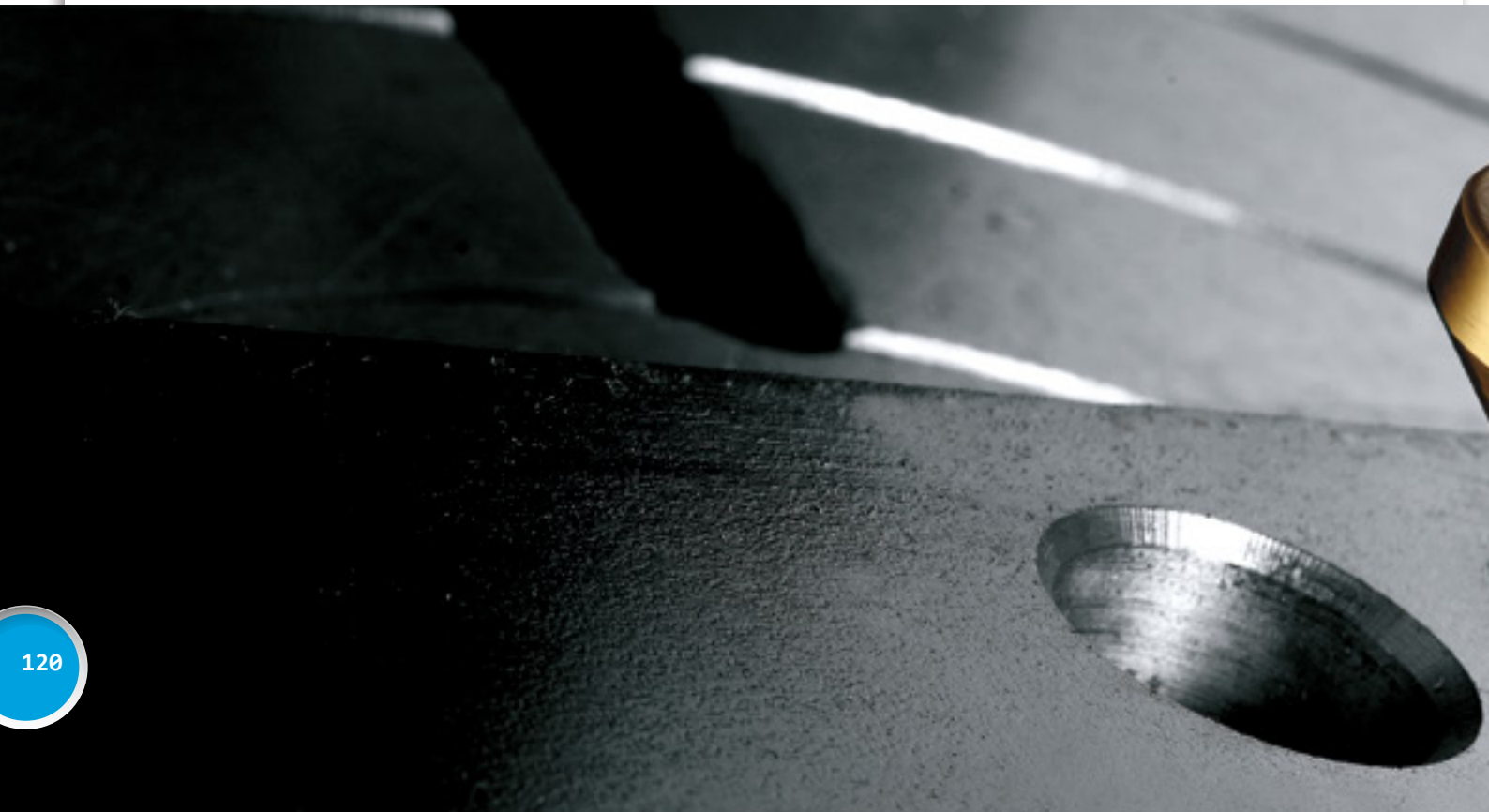

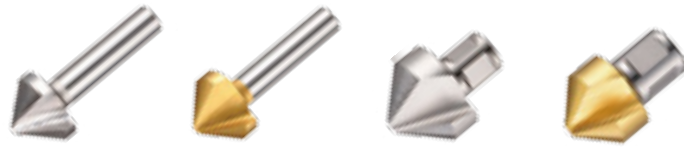

		SCP	SCP TIN	SCS	SCS TIN
Application Guide					
	L-Bar	★★★	★★★	★★★	★★★
	PVC Pipes	★★★	★★★	★★★	★★★
	Railway	★	★	★	★
	Heat Treated Steel	★	★	★	★
	Square pipe	★★★	★★★	★★★	★★★
	Wood	★★★	★★★	★★★	★★★
	Wood With Nails	★★★	★★★	★★★	★★★

★★★ : Excellent, ★★ : Good, ★ : Fair





SCP TYPE PRECISION COUNTERSINK

- Material: M2 High speed steel
- Best result at low cutting speeds.
- CBN ground flutes the cutting edges extremely sharp.

APPLICATIONS



PORTABLE DRILLING MACHINE



PILLAR DRILLING MACHINE



METAL SHEETS SUS304



METAL SHEETS SS41



ALUMINUM

- Increased hardness at the cutting lips.
- Excellent chip clearance.
- For burr-free and chatter-free countersinking as well as for deburring.
- TIN coating increases tool life.

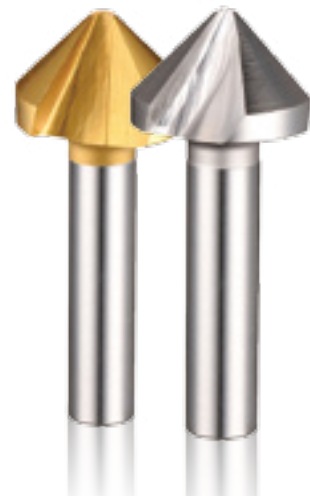
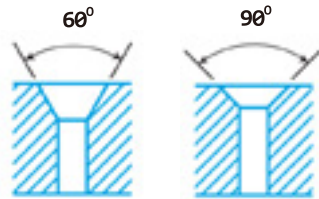

(See page 118 for more cutter's application)

ANGLE	CUTTING EDGES	NOMINAL Ø D	SHANK Ø D	TOTAL LENGTH L	SCP TYPE	SCP TYPE TIN
60°	1	8mm	6mm	50mm	SCP601080	SCP601080TIN
60°	1	10mm	6mm	51mm	SCP601100	SCP601100TIN
60°	1	12mm	8mm	56mm	SCP601120	SCP601120TIN
60°	1	16mm	8mm	58mm	SCP601160	SCP601160TIN
60°	1	20mm	10mm	65mm	SCP601200	SCP601200TIN
60°	1	25mm	10mm	67mm	SCP601250	SCP601250TIN
60°	1	28mm	12mm	69mm	SCP601280	SCP601280TIN
60°	1	30mm	12mm	70mm	SCP601300	SCP601300TIN
60°	1	40mm	15mm	80mm	SCP601400	SCP601400TIN
60°	1	50mm	15mm	86mm	SCP601500	SCP601500TIN
60°	3	8mm	6mm	50mm	SCP603080	SCP603080TIN
60°	3	10mm	6mm	51mm	SCP603100	SCP603100TIN
60°	3	12mm	8mm	56mm	SCP603120	SCP603120TIN
60°	3	16mm	8mm	58mm	SCP603160	SCP603160TIN
60°	3	20mm	10mm	65mm	SCP603200	SCP603200TIN
60°	3	25mm	10mm	67mm	SCP603250	SCP603250TIN
60°	3	28mm	12mm	69mm	SCP603280	SCP603280TIN
60°	3	30mm	12mm	70mm	SCP603300	SCP603300TIN
60°	3	40mm	15mm	80mm	SCP603400	SCP603400TIN
60°	3	50mm	15mm	86mm	SCP603500	SCP603500TIN
90°	1	8mm	6mm	50mm	SCP901080	SCP901080TIN
90°	1	10mm	6mm	51mm	SCP901100	SCP901100TIN
90°	1	12mm	8mm	56mm	SCP901120	SCP901120TIN
90°	1	16mm	8mm	58mm	SCP901160	SCP901160TIN
90°	1	20mm	10mm	65mm	SCP901200	SCP901200TIN
90°	1	25mm	10mm	67mm	SCP901250	SCP901250TIN
90°	1	28mm	12mm	69mm	SCP901280	SCP901280TIN
90°	1	30mm	12mm	70mm	SCP901300	SCP901300TIN
90°	1	40mm	15mm	80mm	SCP901400	SCP901400TIN
90°	1	50mm	15mm	86mm	SCP901500	SCP901500TIN
90°	3	8mm	6mm	50mm	SCP903080	SCP903080TIN
90°	3	10mm	6mm	51mm	SCP903100	SCP903100TIN
90°	3	12mm	8mm	56mm	SCP903120	SCP903120TIN
90°	3	16mm	8mm	58mm	SCP903160	SCP903160TIN
90°	3	20mm	10mm	65mm	SCP903200	SCP903200TIN
90°	3	25mm	10mm	67mm	SCP903250	SCP903250TIN
90°	3	28mm	12mm	69mm	SCP903280	SCP903280TIN
90°	3	30mm	12mm	70mm	SCP903300	SCP903300TIN
90°	3	40mm	15mm	80mm	SCP903400	SCP903400TIN
90°	3	50mm	15mm	86mm	SCP903500	SCP903500TIN

SCS TYPE SHORT COUNTERSINK

- Material: M2 High speed steel
- CBN ground flutes make cutting edges extremely sharp.
- Flute design with 82° point & 90° point for smooth chamfering.
- Precision for de-burring, chamfering and countersinking.
- TIN coating increases tool life up to six times longer than without.**
- Applicable on magnetic drilling machine

APPLICATIONS

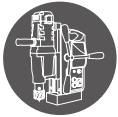

MAGNETIC DRILLING MACHINE



METAL SHEETS SUS304



METAL SHEETS SS41



ALUMINUM



(See page 118 for more cutter's application)

ANGLE	SHANK DIA Ø D	SCS TYPE	SCS TYPE TiN
82°	25mm	SCS82250	SCS82250TiN
82°	30mm	SCS82300	SCS82300TiN
82°	40mm	SCS82400	SCS82400TiN
82°	55mm	SCS82550	SCS82550TiN
90°	25mm	SCS90250	SCS90250TiN
90°	30mm	SCS90300	SCS90300TiN
90°	40mm	SCS90400	SCS90400TiN
90°	55mm	SCS90550	SCS90550TiN
90°	83mm	SCS90830	SCS90830TiN

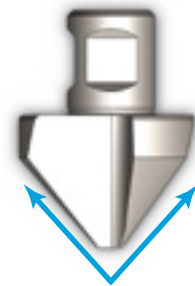

Angle

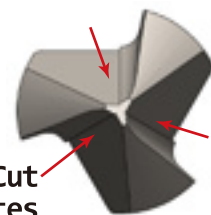

Fast Cut
3 Flutes

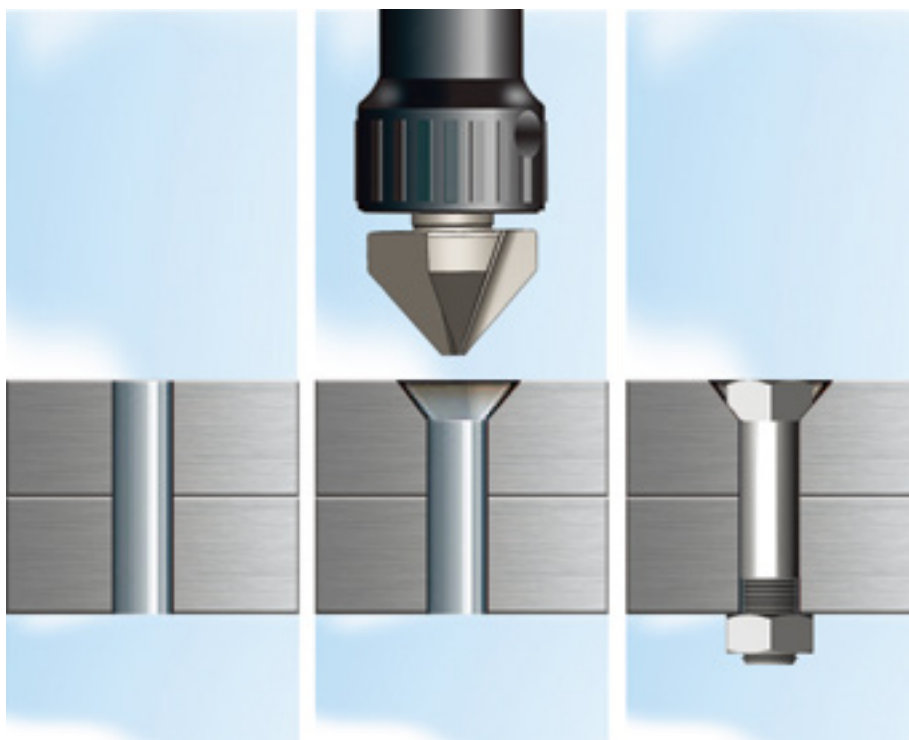
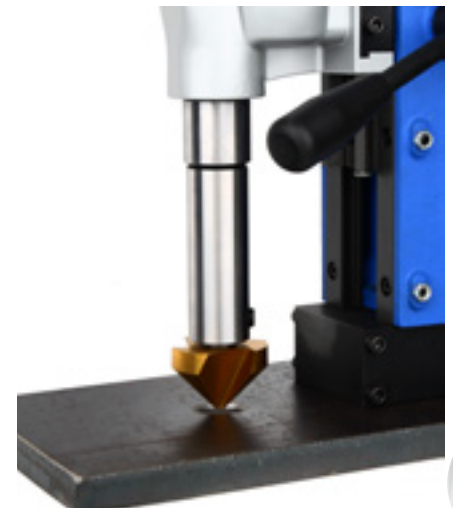



All features in comparison.

Drilling depth	Effective length	Application Guide									
		Metal Sheets SUS304	Metal Sheets SS41	Steel Pipes SUS304	Steel Pipes SS41	Cast Iron	Aluminum	Copper	Bronze	I-Beam	Fiber Glass
38 mm	65 mm	★	★		★	★	★★	★★	★★	★	★
		★★			★			★★		★★★★	★

★★★★ : Excellent,★★ : Good, ★ : Fair

BI-METAL HOLE SAW

- Material: M2 High speed steel
- High cutting efficiency.
- Variable pitch teeth for fast and precise cut.
- Efficient swarf clearance when drilling thick material.
- Applicable on portable and pillar drilling machine.



EASY-CUT

Ø 14mm ~ Ø 152mm

APPLICATIONS



38mm

DRILLING DEPTH



PORTABLE DRILLING MACHINE



PILLAR DRILLING MACHINE



WOOD



FIBER GLASS



PVC PIPES



DIA.(in)	PART NO.	DIA.(in)	PART NO.
9/16"	BM300143	2-5/16"	BM300587
5/8"	BM300159	2-3/8"	BM300603
11/16"	BM300175	2-1/2"	BM300635
3/4"	BM300191	2-9/16"	BM300651
13/16"	BM300206	2-5/8"	BM300667
7/8"	BM300222	2-3/4"	BM300699
15/16"	BM300238	2-7/8"	BM300731
1"	BM300254	3"	BM300762
1-1/16"	BM300269	3-1/8"	BM300794
1-1/8"	BM300286	3-1/4"	BM300826
1-3/16"	BM300302	3-3/8"	BM300857
1-1/4"	BM300318	3-1/2"	BM300889
1-5/16"	BM300334	3-5/8"	BM300921
1-3/8"	BM300349	3-3/4"	BM300953
1-7/16"	BM300365	3-7/8"	BM300984
1-1/2"	BM300381	4"	BM301016
1-9/16"	BM300397	4-1/8"	BM301048
1-5/8"	BM300413	4-1/4"	BM301079
1-11/16"	BM300429	4-3/8"	BM301111
1-3/4"	BM300445	4-1/2"	BM301143
1-13/16"	BM300461	4-3/4"	BM301207
1-7/8"	BM300476	5"	BM301271
2"	BM300508	5-1/4"	BM301334
2-1/16"	BM300524	5-1/2"	BM301397
2-1/8"	BM300539	5-3/4"	BM301461
2-1/4"	BM300572	6"	BM301520

DIA.(mm)	PART NO.	DIA.(mm)	PART NO.
14mm	BM300140	57mm	BM300570
16mm	BM300160	59mm	BM300590
17mm	BM300170	60mm	BM300600
19mm	BM300190	64mm	BM300640
20mm	BM300200	65mm	BM300650
21mm	BM300210	67mm	BM300670
22mm	BM300220	70mm	BM300700
24mm	BM300240	73mm	BM300730
25mm	BM300260	76mm	BM300760
27mm	BM300270	79mm	BM300790
29mm	BM300290	83mm	BM300830
30mm	BM300300	86mm	BM300860
32mm	BM300320	89mm	BM300890
33mm	BM300330	92mm	BM300920
35mm	BM300350	95mm	BM300950
37mm	BM300370	98mm	BM300980
38mm	BM300380	102mm	BM301020
40mm	BM300400	105mm	BM301050
41mm	BM300410	108mm	BM301080
43mm	BM300430	111mm	BM301110
44mm	BM300440	114mm	BM301140
46mm	BM300460	121mm	BM301210
48mm	BM300480	127mm	BM301270
51mm	BM300510	140mm	BM301400
52mm	BM300520	152mm	BM301520
54mm	BM300540		

ACCESSORY ARBOR	PART NO.
φ14 mm~φ30 mm:1/2"-20 thread (from 9/16" ~ 1-3/16")	AB-HW05419D6
φ32 mm~φ152mm:5/8"-18 thread (from 1-1/4" ~ 6")	AB-HW07236D6

ARBOR EXTENSION	PART NO.
5 1/2"L	ED30140
10"L	ED30100
12"L	ED30120
18"L	ED30180

CENTER DRILL	PART NO.
φ14mm~φ152mm: φ6.35mm×80L	M-CD60800

CARBIDE BURR FEATURES

	KPT	Cylinder Shape no end cut	
	KPD	Cylinder Shape Ball Nose	
	KPB	Ball Shape	
	KPO	Oval Shape	
	KPN	Ball Nose Tree Shape	
	KPP	Pointed Tree Shape	
	KPF	Flame Shape	
	KPE	60° Cone Shape	
	KPG	90° Cone Shape	
	KPS	Ball Nose Cone Shape	
	KPA	Cone Shape	
	KPR	Inverted Cone Shape	

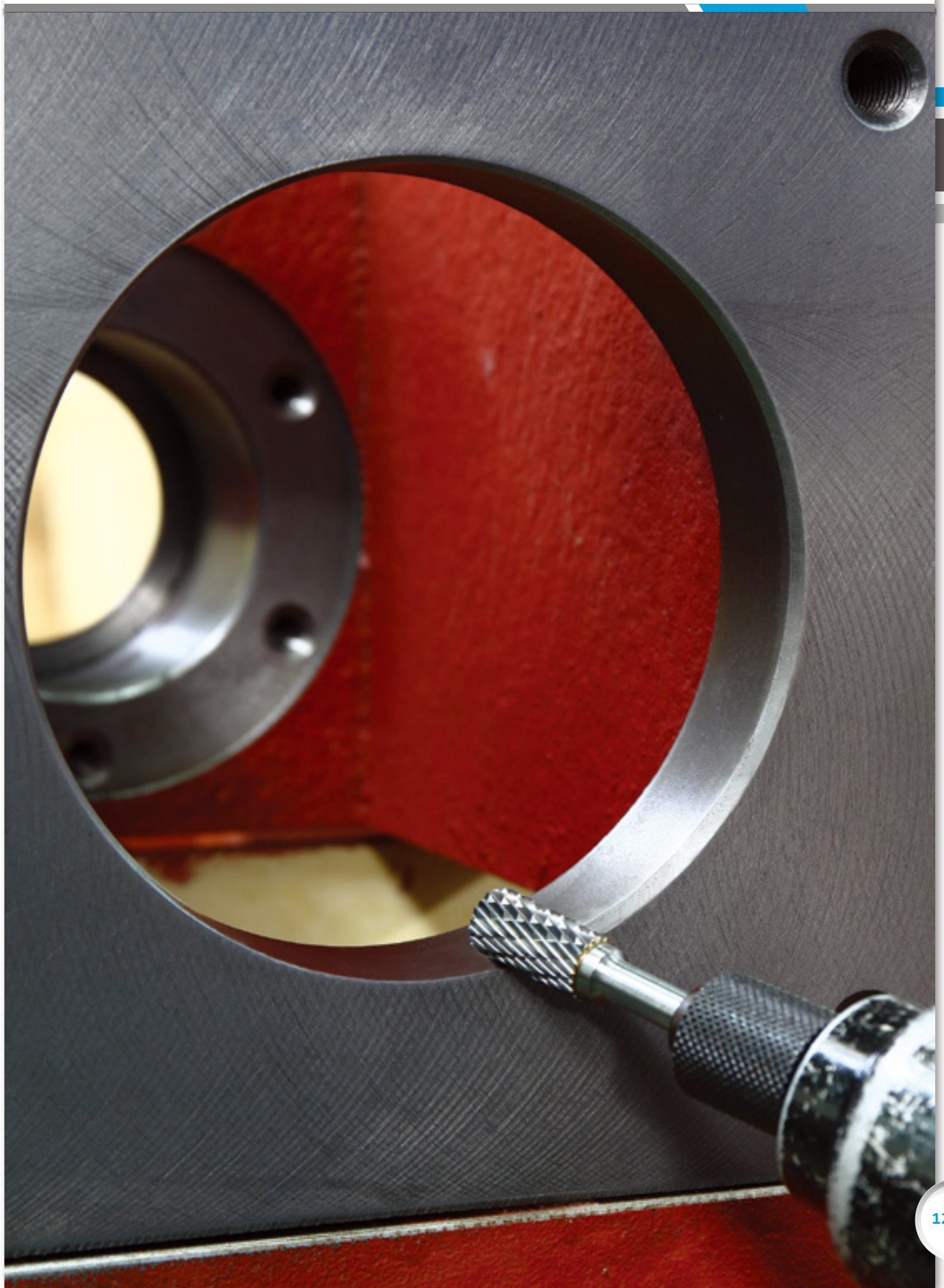

CYLINDER SHAPE

Material: Tungsten Carbide Rotary Burrs
Cutting: Double Cut

- Has a double flute chisel type cutting edge for faster stock removal and better control.
- It can be used with electronically-powered and pneumatically-powered hand-held tools.



KPT

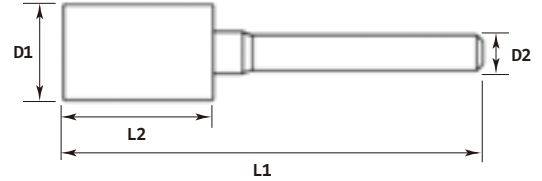
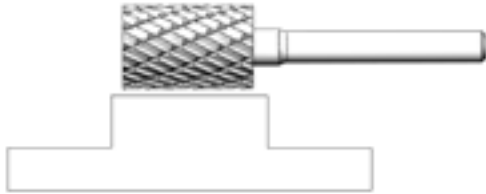

Millimeter :

Ø-D1	L1 (mm)	L2 (mm)	Ø-D2	Item No.
3mm	38mm	14mm	3mm	KPT60030
6mm	50mm	18mm	6mm	KPT60060
8mm	65mm	20mm	6mm	KPT60080
10mm	65mm	20mm	6mm	KPT60100
12mm	70mm	25mm	6mm	KPT60120
16mm	70mm	25mm	6mm	KPT60160

Inches :

Ø-D1	L1 (mm)	L2 (mm)	Ø-D2	Item No.
1/8"	38mm	14mm	1/8"	KPT60031
1/4"	50mm	18mm	1/4"	KPT60063
5/16"	65mm	20mm	1/4"	KPT60079
3/8"	65mm	20mm	1/4"	KPT60095
1/2"	70mm	25mm	1/4"	KPT60127
5/8"	70mm	25mm	1/4"	KPT60158

BALL NOSE SHAPE

Material: Tungsten Carbide Rotary Burrs
Cutting: Double Cut

- Has a double flute chisel type cutting edge for faster stock removal and better control.
- It can be used with electronically-powered and pneumatically-powered hand-held tools.



KPD

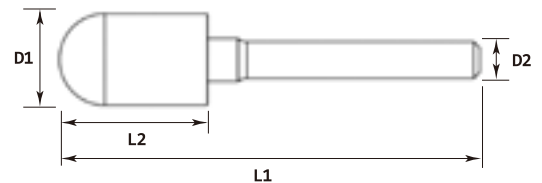
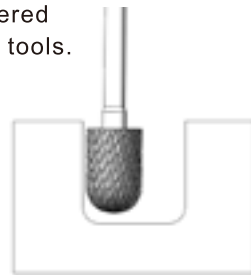

Millimeter :

Ø-D1	L1 (mm)	L2 (mm)	Ø-D2	Item No.
3mm	38mm	14mm	3mm	KPD60030
6mm	50mm	18mm	6mm	KPD60060
8mm	65mm	20mm	6mm	KPD60080
10mm	65mm	20mm	6mm	KPD60100
12mm	70mm	25mm	6mm	KPD60120
16mm	70mm	25mm	6mm	KPD60160

Inches :

Ø-D1	L1 (mm)	L2 (mm)	Ø-D2	Item No.
1/8"	38mm	14mm	1/8"	KPD60031
1/4"	50mm	18mm	1/4"	KPD60063
5/16"	65mm	20mm	1/4"	KPD60079
3/8"	65mm	20mm	1/4"	KPD60095
1/2"	70mm	25mm	1/4"	KPD60127
5/8"	70mm	25mm	1/4"	KPD60158

BALL SHAPE

Material: Tungsten Carbide Rotary Burrs

Cutting: Double Cut

- Has a double flute chisel type cutting edge for faster stock removal and better control.
- It can be used with electronically-powered and pneumatically-powered hand-held tools.

KPB

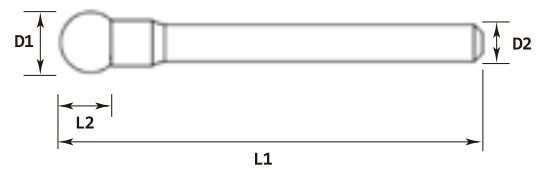

Millimeter :

Ø-D1	L1 (mm)	L2 (mm)	Ø-D2	Item No.
3mm	38mm	3mm	3mm	KPB60030
6mm	50mm	5mm	6mm	KPB60060
8mm	65mm	7mm	6mm	KPB60080
10mm	65mm	9mm	6mm	KPB60100
12mm	70mm	11mm	6mm	KPB60120
16mm	70mm	15mm	6mm	KPB60160

Inches :

Ø-D1	L1 (mm)	L2 (mm)	Ø-D2	Item No.
1/8"	38mm	3mm	1/8"	KPB60031
1/4"	50mm	5mm	1/4"	KPB60063
5/16"	65mm	7mm	1/4"	KPB60079
3/8"	65mm	9mm	1/4"	KPB60095
1/2"	70mm	11mm	1/4"	KPB60127
5/8"	70mm	15mm	1/4"	KPB60158

OVAL SHAPE

Material: Tungsten Carbide Rotary Burrs

Cutting: Double Cut

- Has a double flute chisel type cutting edge for faster stock removal and better control.
- It can be used with electronically-powered and pneumatically-powered hand-held tools.

KPO

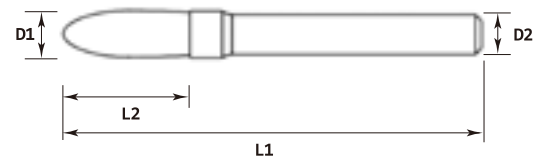

Millimeter :

Ø-D1	L1 (mm)	L2 (mm)	Ø-D2	Item No.
3mm	38mm	6mm	3mm	KPO60030
6mm	50mm	9mm	6mm	KPO60060
8mm	65mm	14mm	6mm	KPO60080
10mm	65mm	15mm	6mm	KPO60100
12mm	70mm	21mm	6mm	KPO60120
16mm	70mm	24mm	6mm	KPO60160

Inches :

Ø-D1	L1 (mm)	L2 (mm)	Ø-D2	Item No.
1/8"	38mm	6mm	1/8"	KPO60031
1/4"	50mm	9mm	1/4"	KPO60063
5/16"	65mm	14mm	1/4"	KPO60079
3/8"	65mm	15mm	1/4"	KPO60095
1/2"	70mm	21mm	1/4"	KPO60127
5/8"	70mm	24mm	1/4"	KPO60158

BALL NOSE TREE SHAPE

Material: Tungsten Carbide Rotary Burrs
Cutting: Double Cut

- Has a double flute chisel type cutting edge for faster stock removal and better control.
- It can be used with electronically-powered and pneumatically-powered hand-held tools.

KPN

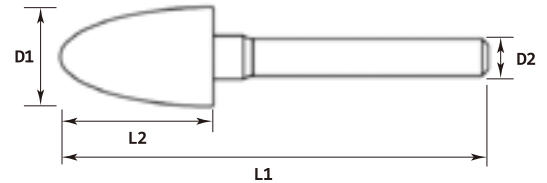
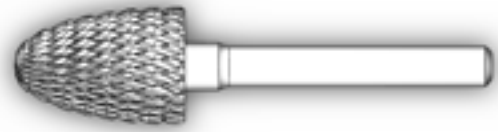

Millimeter :

Ø-D1	L1 (mm)	L2 (mm)	Ø-D2	Item No.
3mm	38mm	14mm	3mm	KPN60030
6mm	50mm	18mm	6mm	KPN60060
8mm	65mm	20mm	6mm	KPN60080
10mm	65mm	20mm	6mm	KPN60100
12mm	70mm	25mm	6mm	KPN60120
16mm	70mm	25mm	6mm	KPN60160

Inches :

Ø-D1	L1 (mm)	L2 (mm)	Ø-D2	Item No.
1/8"	38mm	14mm	1/8"	KPN60031
1/4"	50mm	18mm	1/4"	KPN60063
5/16"	65mm	20mm	1/4"	KPN60079
3/8"	65mm	20mm	1/4"	KPN60095
1/2"	70mm	25mm	1/4"	KPN60127
5/8"	70mm	25mm	1/4"	KPN60158

POINTED TREE SHAPE

Material: Tungsten Carbide Rotary Burrs
Cutting: Double Cut

- Has a double flute chisel type cutting edge for faster stock removal and better control.
- It can be used with electronically-powered and pneumatically-powered hand-held tools.

KPP

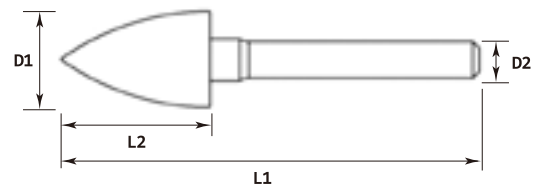
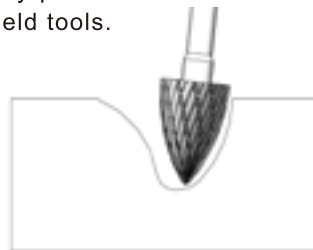

Millimeter :

Ø-D1	L1 (mm)	L2 (mm)	Ø-D2	Item No.
3mm	38mm	14mm	3mm	KPP60030
6mm	50mm	18mm	6mm	KPP60060
8mm	65mm	18mm	6mm	KPP60080
10mm	65mm	20mm	6mm	KPP60100
12mm	70mm	25mm	6mm	KPP60120
16mm	70mm	25mm	6mm	KPP60160

Inches :

Ø-D1	L1 (mm)	L2 (mm)	Ø-D2	Item No.
1/8"	38mm	14mm	1/8"	KPP60031
1/4"	50mm	18mm	1/4"	KPP60063
5/16"	65mm	18mm	1/4"	KPP60079
3/8"	65mm	20mm	1/4"	KPP60095
1/2"	70mm	25mm	1/4"	KPP60127
5/8"	70mm	25mm	1/4"	KPP60158

FLAME SHAPE

Material: Tungsten Carbide Rotary Burrs
Cutting: Double Cut

- Has a double flute chisel type cutting edge for faste stock removal and better control.
- It can be used with electronically-powered and pneumatically-powered hand-held tools.

KPF

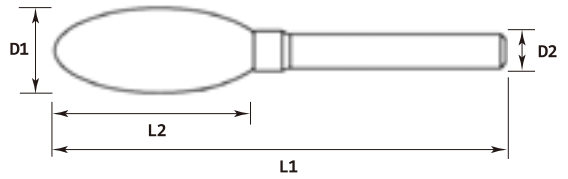

Millimeter :

Ø-D1	L1 (mm)	L2 (mm)	Ø-D2	Item No.
3mm	38mm	9mm	3mm	KPF60030
6mm	50mm	12mm	6mm	KPF60060
8mm	65mm	20mm	6mm	KPF60080
10mm	65mm	20mm	6mm	KPF60100
12mm	70mm	32mm	6mm	KPF60120
16mm	70mm	36mm	6mm	KPF60160

Inches :

Ø-D1	L1 (mm)	L2 (mm)	Ø-D2	Item No.
1/8"	38mm	9mm	1/8"	KPF60031
1/4"	50mm	12mm	1/4"	KPF60063
5/16"	65mm	20mm	1/4"	KPF60079
3/8"	65mm	20mm	1/4"	KPF60095
1/2"	70mm	32mm	1/4"	KPF60127
5/8"	70mm	36mm	1/4"	KPF60158

60° CONE SHAPE

Material: Tungsten Carbide Rotary Burrs
Cutting: Double Cut

- Has a double flute chisel type cutting edge for faster stock removal and better control.
- It can be used with electronically-powered and pneumatically-powered hand-held tools.

KPE

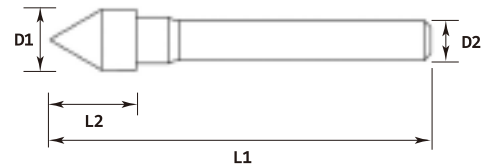
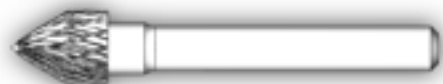
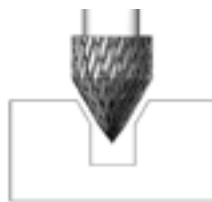

Millimeter :

Ø-D1	L1 (mm)	L2 (mm)	Ø-D2	Item No.
3mm	38mm	3mm	3mm	KPE60030
6mm	50mm	6mm	6mm	KPE60060
8mm	65mm	14mm	6mm	KPE60080
10mm	65mm	14mm	6mm	KPE60100
12mm	70mm	16mm	6mm	KPE60120
16mm	70mm	20mm	6mm	KPE60160

Inches :

Ø-D1	L1 (mm)	L2 (mm)	Ø-D2	Item No.
1/8"	38mm	3mm	1/8"	KPE60031
1/4"	50mm	6mm	1/4"	KPE60063
5/16"	65mm	14mm	1/4"	KPE60079
3/8"	65mm	14mm	1/4"	KPE60095
1/2"	70mm	16mm	1/4"	KPE60127
5/8"	70mm	20mm	1/4"	KPE60158

90° CONE SHAPE

Material: Tungsten Carbide Rotary Burrs
Cutting: Double Cut

- Has a double flute chisel type cutting edge for faster stock removal and better control.
- It can be used with electronically-powered and pneumatically-powered hand-held tools.

KPG

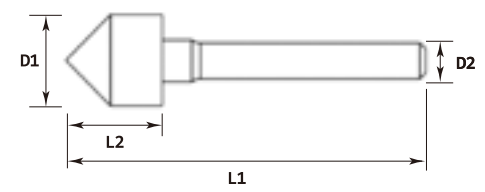

Millimeter :

Ø-D1	L1 (mm)	L2 (mm)	Ø-D2	Item No.
3mm	38mm	3mm	3mm	KPG60030
6mm	50mm	3mm	6mm	KPG60060
8mm	65mm	11mm	6mm	KPG60080
10mm	65mm	11mm	6mm	KPG60100
12mm	70mm	13mm	6mm	KPG60120
16mm	70mm	14mm	6mm	KPG60160

Inches :

Ø-D1	L1 (mm)	L2 (mm)	Ø-D2	Item No.
1/8"	38mm	3mm	1/8"	KPG60031
1/4"	50mm	3mm	1/4"	KPG60063
5/16"	65mm	11mm	1/4"	KPG60079
3/8"	65mm	11mm	1/4"	KPG60095
1/2"	70mm	13mm	1/4"	KPG60127
5/8"	70mm	14mm	1/4"	KPG60158

BALL NOSE CONE SHAPE

Material: Tungsten Carbide Rotary Burrs
Cutting: Double Cut

- Has a double flute chisel type cutting edge for faster stock removal and better control.
- It can be used with electronically-powered and pneumatically-powered hand-held tools.

KPS

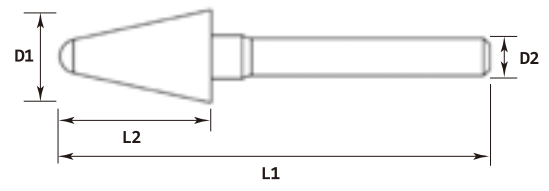
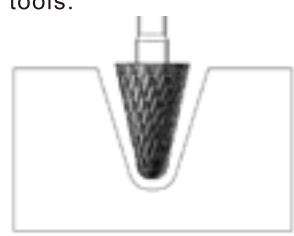

Millimeter :

Ø-D1	L1 (mm)	L2 (mm)	Ø-D2	Item No.
3mm	38mm	3mm	3mm	KPS60030
6mm	50mm	3mm	6mm	KPS60060
8mm	65mm	11mm	6mm	KPS60080
10mm	65mm	11mm	6mm	KPS60100
12mm	70mm	13mm	6mm	KPS60120
16mm	70mm	14mm	6mm	KPS60160

Inches :

Ø-D1	L1 (mm)	L2 (mm)	Ø-D2	Item No.
1/8"	38mm	3mm	1/8"	KPS60031
1/4"	50mm	3mm	1/4"	KPS60063
5/16"	65mm	11mm	1/4"	KPS60079
3/8"	65mm	11mm	1/4"	KPS60095
1/2"	70mm	13mm	1/4"	KPS60127
5/8"	70mm	14mm	1/4"	KPS60158

CONE SHAPE

Material: Tungsten Carbide Rotary Burrs

Cutting: Double Cut

- Has a double flute chisel type cutting edge for faster stock removal and better control.
- It can be used with electronically-powered and pneumatically-powered hand-held tools.

KPA

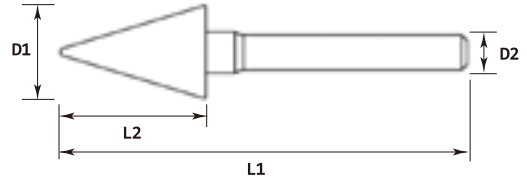

Millimeter :

Ø-D1	L1 (mm)	L2 (mm)	Ø-D2	Item No.
3mm	38mm	14mm	3mm	KPA60030
6mm	50mm	18mm	6mm	KPA60060
8mm	65mm	18mm	6mm	KPA60080
10mm	65mm	20mm	6mm	KPA60100
12mm	70mm	25mm	6mm	KPA60120
16mm	70mm	25mm	6mm	KPA60160

Inches :

Ø-D1	L1 (mm)	L2 (mm)	Ø-D2	Item No.
1/8"	38mm	14mm	1/8"	KPA60031
1/4"	50mm	18mm	1/4"	KPA60063
5/16"	65mm	18mm	1/4"	KPA60079
3/8"	65mm	20mm	1/4"	KPA60095
1/2"	70mm	25mm	1/4"	KPA60127
5/8"	70mm	25mm	1/4"	KPA60158

INVERTED CONE SHAPE

Material: Tungsten Carbide Rotary Burrs

Cutting: Double Cut

- Has a double flute chisel type cutting edge for faster stock removal and better control.
- It can be used with electronically-powered and pneumatically-powered hand-held tools.

KPR

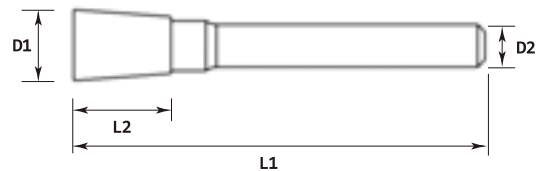

Millimeter :

Ø-D1	L1 (mm)	L2 (mm)	Ø-D2	Item No.
3mm	38mm	4mm	3mm	KPR60030
6mm	50mm	8mm	6mm	KPR60060
8mm	65mm	10mm	6mm	KPR60080
10mm	65mm	10mm	6mm	KPR60100
12mm	70mm	13mm	6mm	KPR60120
16mm	70mm	19mm	6mm	KPR60160

Inches :

Ø-D1	L1 (mm)	L2 (mm)	Ø-D2	Item No.
1/8"	38mm	4mm	1/8"	KPR60031
1/4"	50mm	8mm	1/4"	KPR60063
5/16"	65mm	10mm	1/4"	KPR60079
3/8"	65mm	10mm	1/4"	KPR60095
1/2"	70mm	13mm	1/4"	KPR60127
5/8"	70mm	19mm	1/4"	KPR60158



SHAJENG HARDWARE Co., Ltd

No. 55 Shin Ren 2nd St., Dali Dist., Taichung City, Taiwan 41249

TEL · 886-4-22705610 FAX · 886-4-22736363

E-mail · info@3keego.com

www.3keego.com