

GENERAL CATALOGUE

Machines fully designed and manufactured in Italy

ООО «ПО ИП»

Тел: +7 (812)602-77-08 E-mail:

info@poip.ru www.poip.ru

PERTICI[®]
INDUSTRIES

Pertici Industries is a global leader in technology for the processing of aluminum and PVC extrusions, dedicated to the window and door industry and other industrial sectors (automotive, furniture, railway, lighting, heating, energy, naval).

Experience, expertise and continuous improvement allow the realization of products based on advanced technologies and able to meet the real needs of customers in all markets around the world.

Pertici develops its machinery so that each component must obtain the best efficiency, flexibility and ease of use and maintenance as well as maximum reliability.

The proven ability to produce complex machinery for the largest customers around the world is the basis for achieving the best performance and highest quality in every market and in every industry.

OUR BRANDS

PERTICI[®]
INDUSTRIES

PERTICI
CARE 

PERTICI
CLOUD 



COMPANY //

Pertici was founded in 1965 by Leto Pertici under the name of Costruzioni Meccaniche Pertici. Originally, the company's activity was focused on the production of traditional woodworking machinery, later developing the construction of machinery for the aluminum and PVC window and door industry.

The growth of volumes and the extension of the production site, together with a production cycle completely controlled internally, have allowed the Company to propose solutions characterized by the highest quality and reliability, suitable to meet the needs of any type of customer. Thanks to these characteristics, since the '80s Pertici has experienced an intense international expansion that has allowed it to create a solid distribution network all over the world.

In over 50 years of activity, the Company has installed tens of thousands of plants in Europe, America, Africa, Asia and Oceania. Currently, Pertici Industries is a world leader in the design and construction of machines and systems for processing aluminum and PVC profiles, used for windows and doors and other industrial sectors.

The Company develops and implements cutting-edge technologies, guaranteeing a global customer service that includes assistance, maintenance, installation, support and timely training. The competence and radical experience of the entire staff, together with the strong consolidation on the global market, are essential elements of the strategy of constant development that characterizes the Company.



PERTICI TEAM //

Thanks to the experience gained over the years, the **Pertici Industries Team** has been able to structure and transform itself to meet all market needs, also favored by the natural attitude to an international approach.

Professional skills and competences have allowed the development of innovative and reliable products for both the windows and doors and industrial sectors.

The company culture favors a climate of synergic trust and recognizes the human factor as the key to providing the best in terms of technology, continuous improvement and customer service.



PERTICI CARE //

Pertici Care creates a new world around the customer through a new service and support. The new Pertici Care service allows maximum efficiency for every customer's need with fast answers to problems so as to minimize downtime.

The new Pertici Care

- **Remote Customer Care: Pertici Connect**
- **Training & Installation**
- **On-site assistance**
- **Check up and scheduled maintenance**
- **Spare parts**
- **Modifications and refitting of Pertici machines**

Remote Customer Care: Pertici Connect

In addition to the normal remote assistance, Pertici has activated an augmented reality assistance service that, through a computer and dedicated software, allows an interactive connection between the customer and Pertici technicians who can work in 7 different languages. Thanks to the activation of a direct video, Pertici's experts will be able to assist customers in the field by diagnosing and solving problems in real time. The service allows to make a series of interactions with photos, videos, share in a bidirectional way screens, models and check lists giving precise indications on where to operate through the freeze image pointing and drawing function. Pertici Connect can also be used with dedicated Smart Glasses that allow you to keep your hands operational without having to

move away from your workstation. Pertici Connect is also useful for practical demonstrations and optimization of maintenance activities as well as to facilitate all **Training & Installation** activities.

On-site assistance

Thanks to our distribution network we can guarantee the presence of qualified technicians wherever you are for competent advice and rapid identification and solution of problems.

Check up and scheduled maintenance

Pertici has set up several checkup and scheduled maintenance programs that can be customized in the number and type of interventions according to customer needs. There are differentiated discounts for the purchase of spare parts.

Spare parts

Pertici provides customers with a spare parts warehouse that allows maximum speed of supply at advantageous purchase conditions.

Modifications and refitting of Pertici machinery

Pertici is available for customers for modifications and refitting of machinery with the aim of protecting the customer in all his needs.

Overview



MACHINING CENTERS //	11
P524 - P527 - P529	12 - 13
P304 - P307 - P309	14 - 15
MC 400 - MC 700	16 - 17
P104 - P107	18 - 19
FC 1000	20 - 21



MACHINING CENTERS SOFTWARE //	23
P-CAM - P-SIMULATION	24
P-REPORT - P-INTERFACE	25



CUTTING CENTERS //	27
SC 55 - SC 65	28 - 29

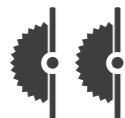

DOUBLE HEAD CUTTING MACHINES //	31
600 TSE	32
550 TSE	33
500 TSE	34
500 TS - 500 CD - 500 D2K	35
402 IP - 403 IP	36



CNC END MILLING MACHINES //	39
WLS	40
P45	41



SINGLE HEAD CUTTING MACHINES //	43
CMPE 65	44
50 A - 50 AE	45
55 FS - 55 FSE	46
40 MP	47
BS 772	48
BS 773 - BS 774	49

Overview



LENGTH STOPS AND ROLLER CONVEYORS //	51
VISUAL RF	52
VISUAL EM	53
ROLLER	53



COPY ROUTERS END MILLING CRIMPING MACHINES //	55
CR 105	56
CR 100	57
CR 106A	58
CR 110	59
ML 123	60
ML 124	61
ML 200	62
RF 350	63
RF 3000	64
HP 601 - HP 620	65
WSA	66
ML 142	67



WELDING MACH. - CORNER CLEANERS - SCREW DRIVERS //	69
WM2	70
WM1	71
CM 170	72
CM 15	73
ASD 30	73



ASSEMBLY TABLES AND TROLLEYS //	75
BL VPPH	76
BL 3002	76
BL 300	77
IRON BUSH	77
IRON END	77
IRON CAR	78
IRON WORTH	78
IRON READY	78
IRON GASKETS	78
IRON STRONG	79
IRON CLEVER	79
IRON HELP	79

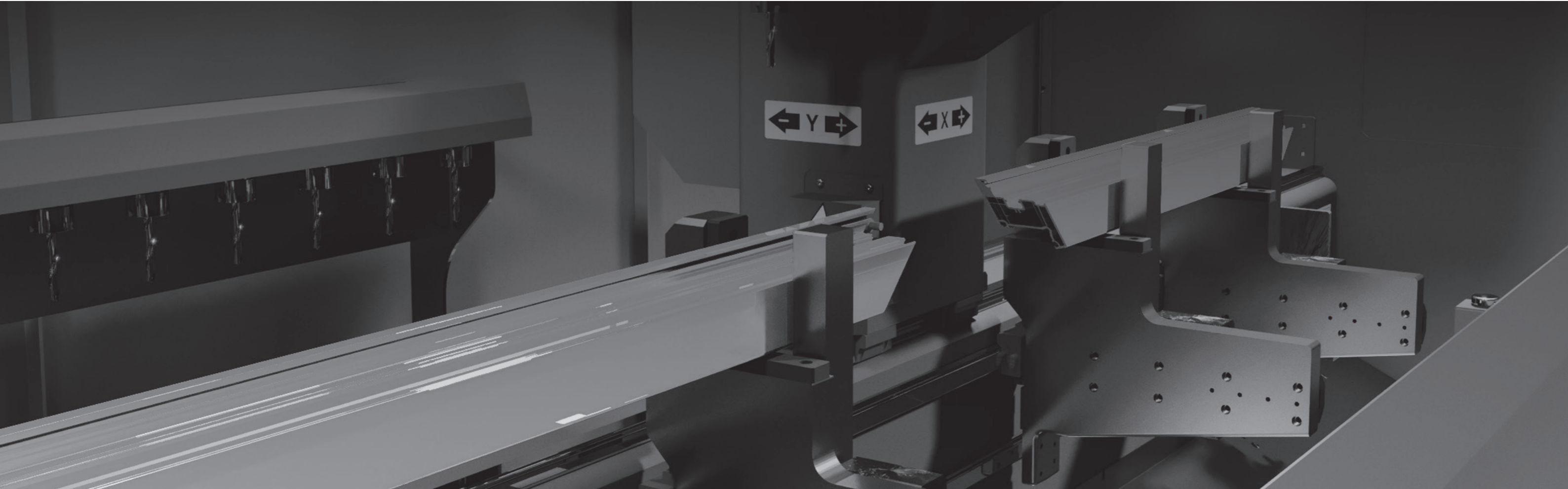

MACHINING CENTERS //

Pertici Industries machining centers are the ideal tool to perform various types of machining operations on aluminum, PVC, steel and light alloy profiles in general. They represent the most advanced solution to combine high productivity, flexibility and guarantee high quality standards. Their main use embraces two areas, the window and door frames and the industrial one.

The range consists of 4- and 5-axis machines with useful working dimensions from 3.2 to 9 m, all interfaced by 3D CAD-CAM software, and prepared for connection with third party applications.

The research and development department also offers a machine customization service to meet specific customer requirements.

P524
P527
P529

CNC machining center with 5 controlled axis, designed to execute the operations of milling, drilling, threading, cutting, end milling on bars or pieces of aluminum, PVC light alloys and steel.

Three available versions, 4 m, 7 m, 9 m with two different working modes: one only working area or pendular mode with two independent working areas. The electric spindle with 8.5 kW (11 kW as option) power in S with HSK-F63 cone connection, enables to also perform difficult operations common in the industrial field. In all versions the electric spindle, thanks to the combination of the A and C axis, can be positioned at any angle from +/- 90° for the A axis and +/- 320° for the C axis. A 500 mm blade unit available as an option.

The machining center has a rotating 10 position magazine housed on board the carriage with the possibility to store standard cutters and disc cutters with a maximum diameter of 180 mm. The 450 mm blade tool with HSK-F63 cone attachment is housed separately in a dedicated magazine and can work using the 5 interpolated axes of the electro-head to perform compound cuts, straight cuts, end-cutting and trimming operations.

Depending on the version, the machining center is equipped with 4 / 8 automatic clamps which are positioned along the X axis in automatic mode by means of a mobile carriage or independently with a dedicated axis (optional). In the version with independent clamps movement, after the execution of the cut, it is possible to divide the piece for the next machining on the profile end.

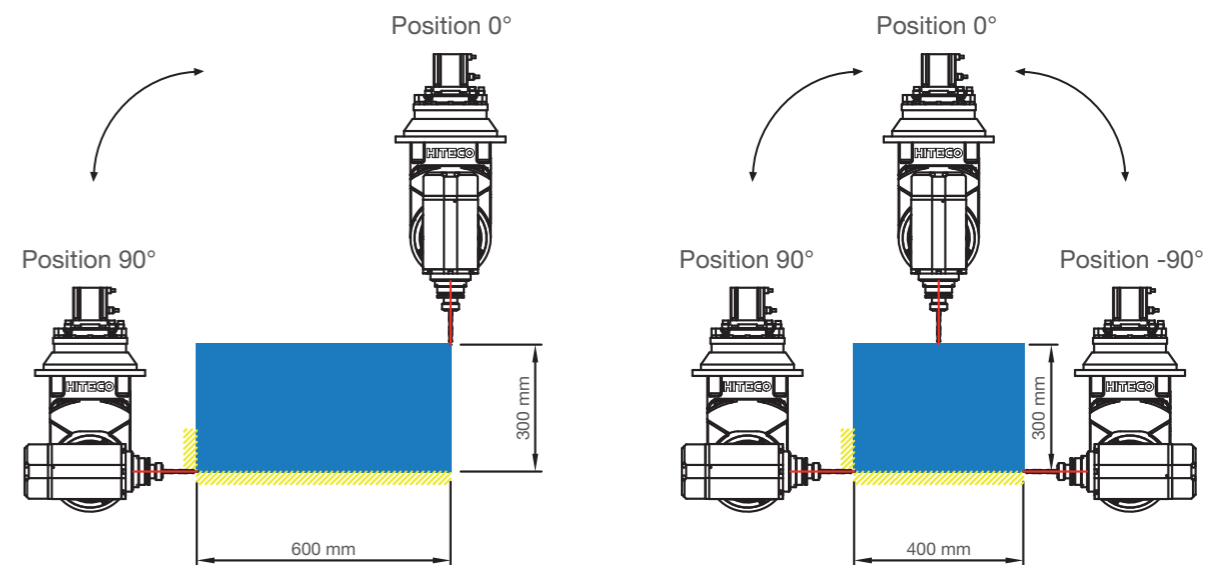
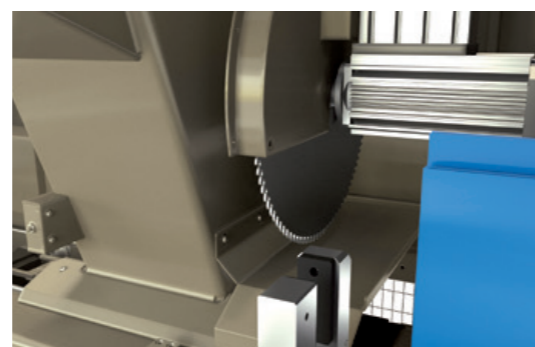
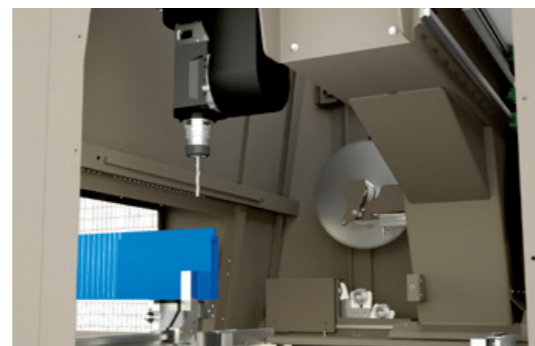
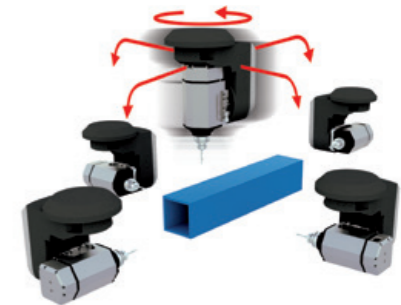

P304
P307
P309

CNC with 4 controlled axis, designed to execute the operations of milling, drilling, threading, cutting, end milling on bars or pieces of aluminum, PVC, light alloys and steel. There are three available versions, 4 m , 7 m and 9 m with two different working methods: one full working area or the pendular mode with two independent working areas.

The electric spindle with 8,5 kW (10 kW as option) power in S1 with HSK-F63 cone connection, enables to also perform difficult operations common in the industrial field. In all versions the electric spindle continuously rotates along the A axis from 0° to 180° allowing to work in every position included in this range.

The machining center has a 10 position rotating magazine on the spindle for standard cutters and end milling disks. Depending on the version the machine has 4 or 8 automatic clamps that automatically move to position along the X axis by the spindle or independently by a dedicated axis (as an option). A 500 mm blade unit available as an option.

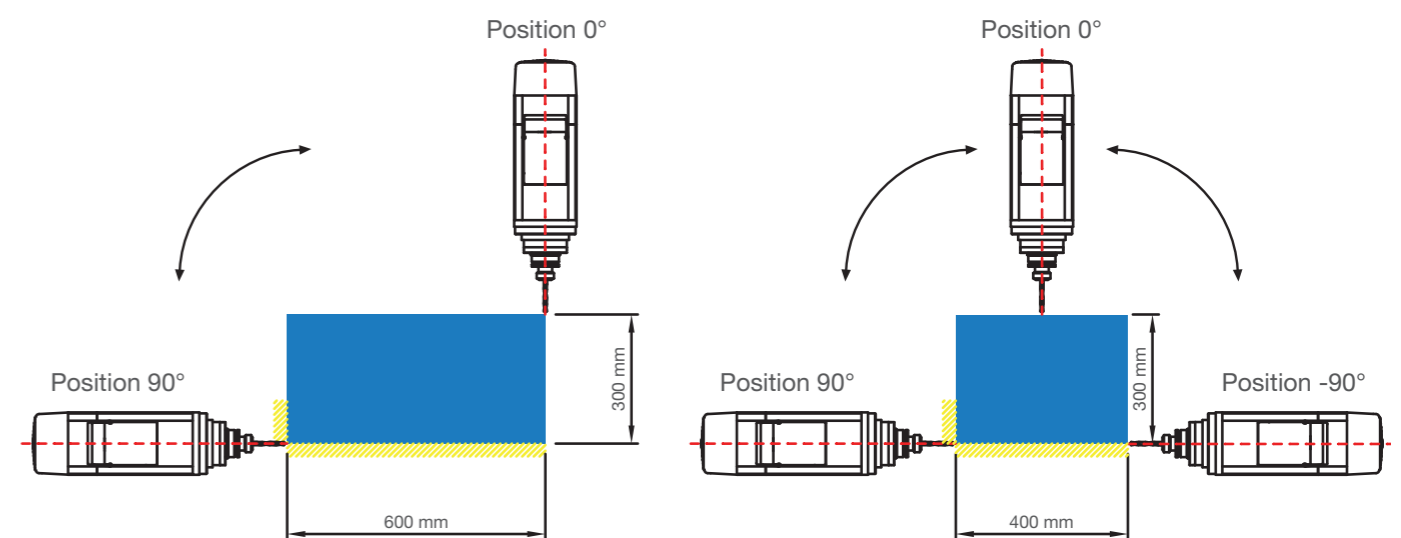
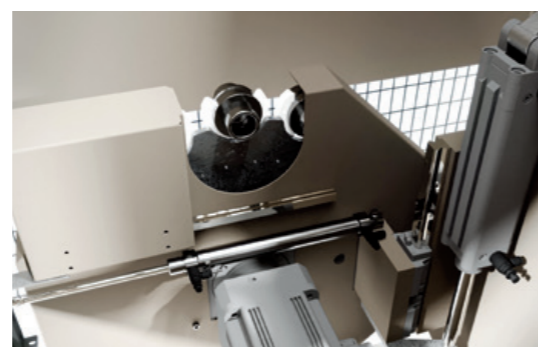
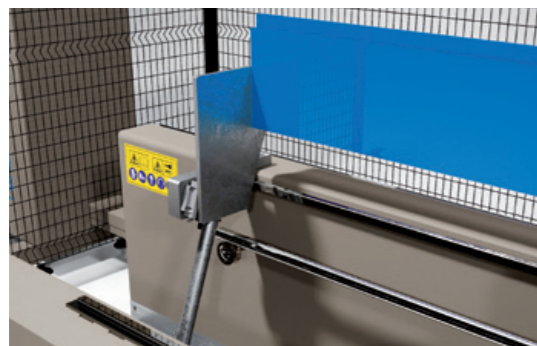
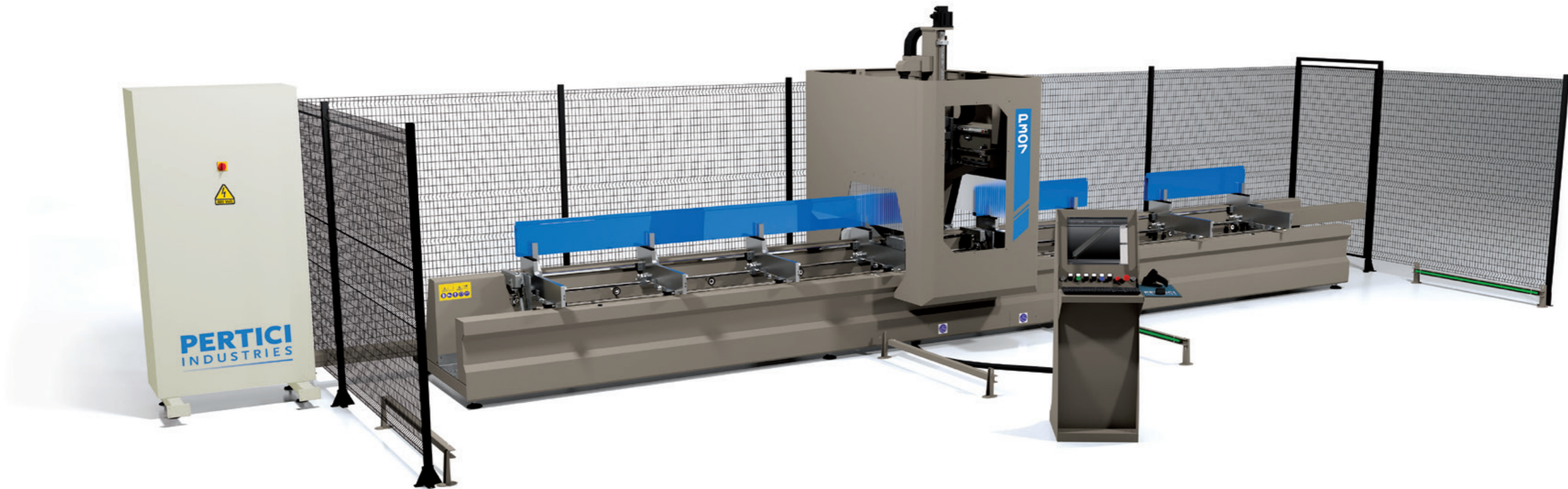
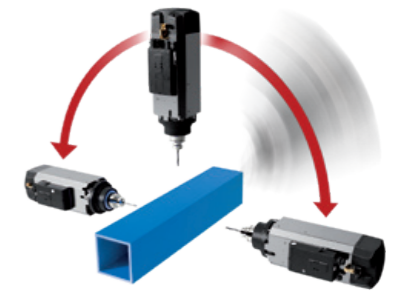

MC 400
MC 700

CNC machining center with 4 controlled axes, designed to perform machining operations on bars or parts in aluminum, PVC, light alloys in general and steel with a thickness of 3 mm. The working range in the MC 400 version allows to machine profiles up to 4,175 m. In the MC 700 version with two pneumatic reference stops allows profiles up to 7,3 m to be processed in two different modes: a single working area or the pendulum mode with two independent working areas.

MC 400 has a rotating table that allows to machine the profile at any angle between + 90° and - 90° while the MC 700 has 2 separate rotating tables. Both models carry a 7,5 KW HSK-63F electro spindle.

The centers have an 8-place tool magazine, in the MC 400 version fixed on the base, in the MC 700 version dynamic on the working area, which allows a quick pick-up from every point of the machine. The clamping of the profile is guaranteed by four / eight clamps depending on the version, with reduced overall dimensions and independent movement.

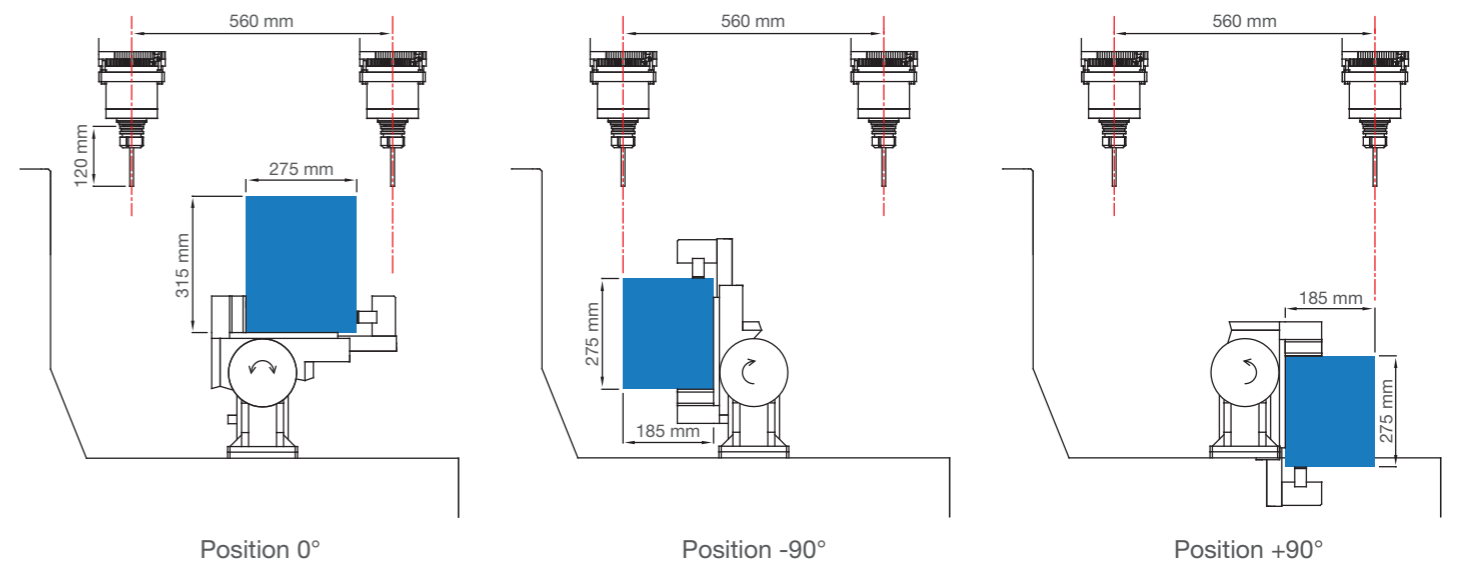
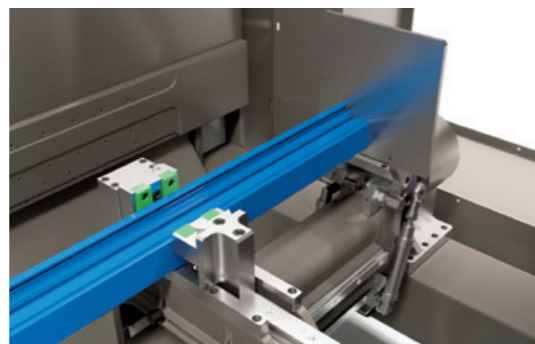
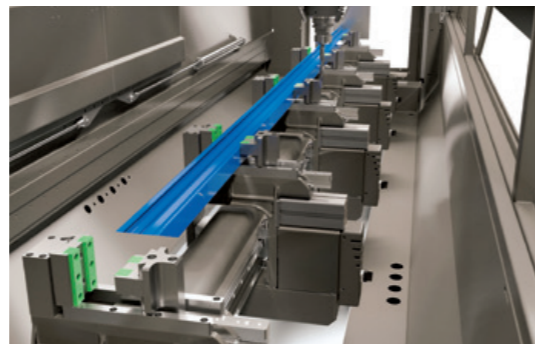
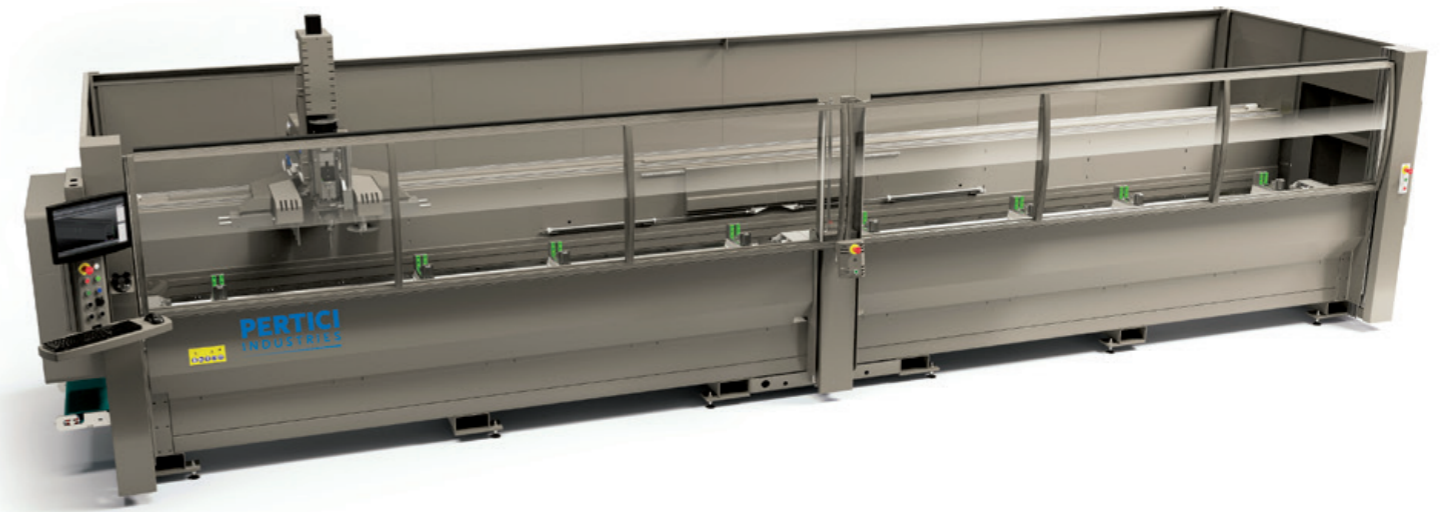
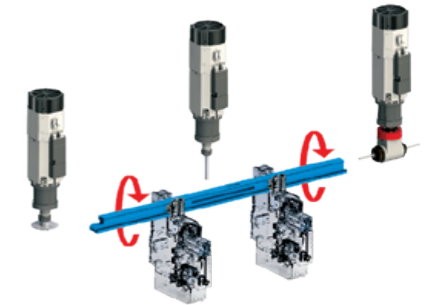

P104
P107

CNC machining center with 4 controlled axes, designed to perform machining operations on bars or parts in aluminum, PVC, light alloys in general and steel with a thickness of 2 mm. The working range with single pneumatic zero stop in the P104 version allows to machine profiles up to 3.2 m, length that doubles with the optional installation of a second zero stop. The working range in the P107 version with two pneumatic reference stops allows profiles up to 7 m to be processed in two different modes: a single working area or the pendulum mode with two independent working areas.

Thanks to the 4th rotating axis, the electro spindle (5 kW) can machine the profile at any angle between 0° and 180°.

The centers have an 8-place tool magazine, in the P104 version fixed on the base, in the P107 version dynamic on the working area, which allows a quick pick-up from every point of the machine. The clamping of the profile is guaranteed by four / eight clamps depending on the version, with reduced overall dimensions to allow maximum machinability even with very short workpieces.

The moving mast carriage also enables high useful working dimensions to be achieved with relatively compact machine dimensions, offering the operator excellent ergonomics in workpiece loading/unloading.

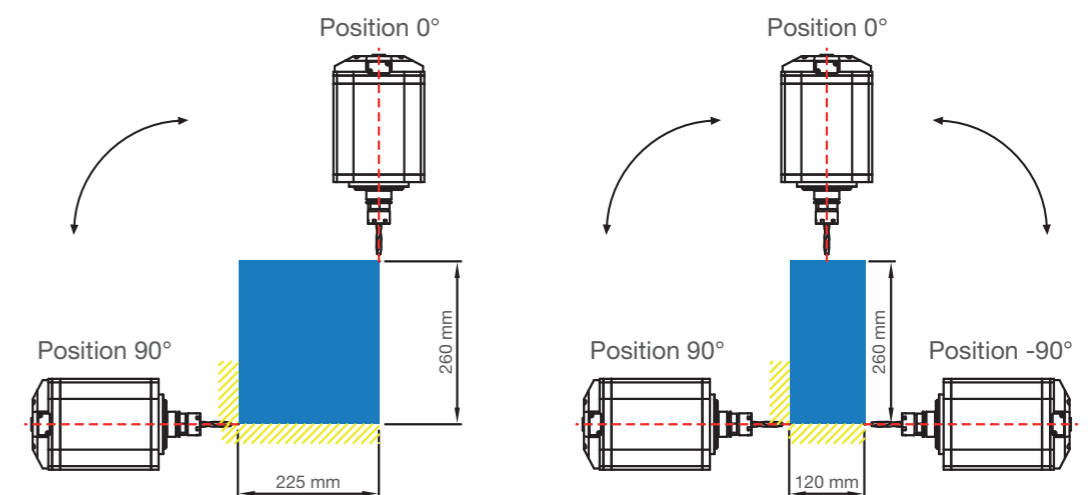
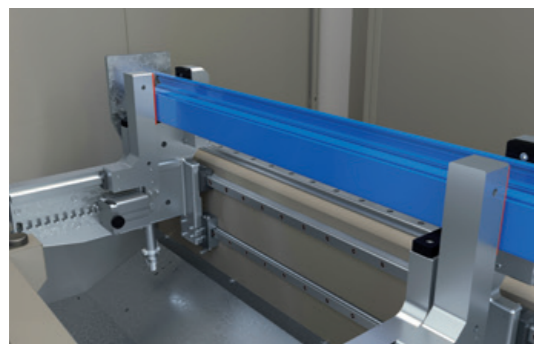
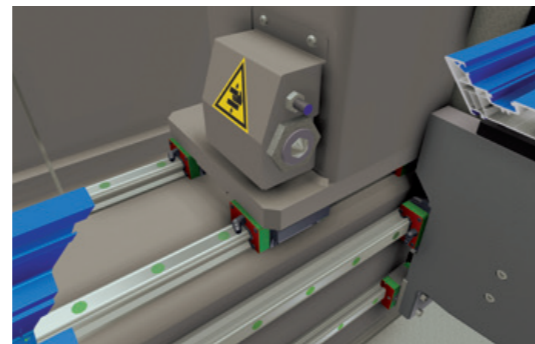
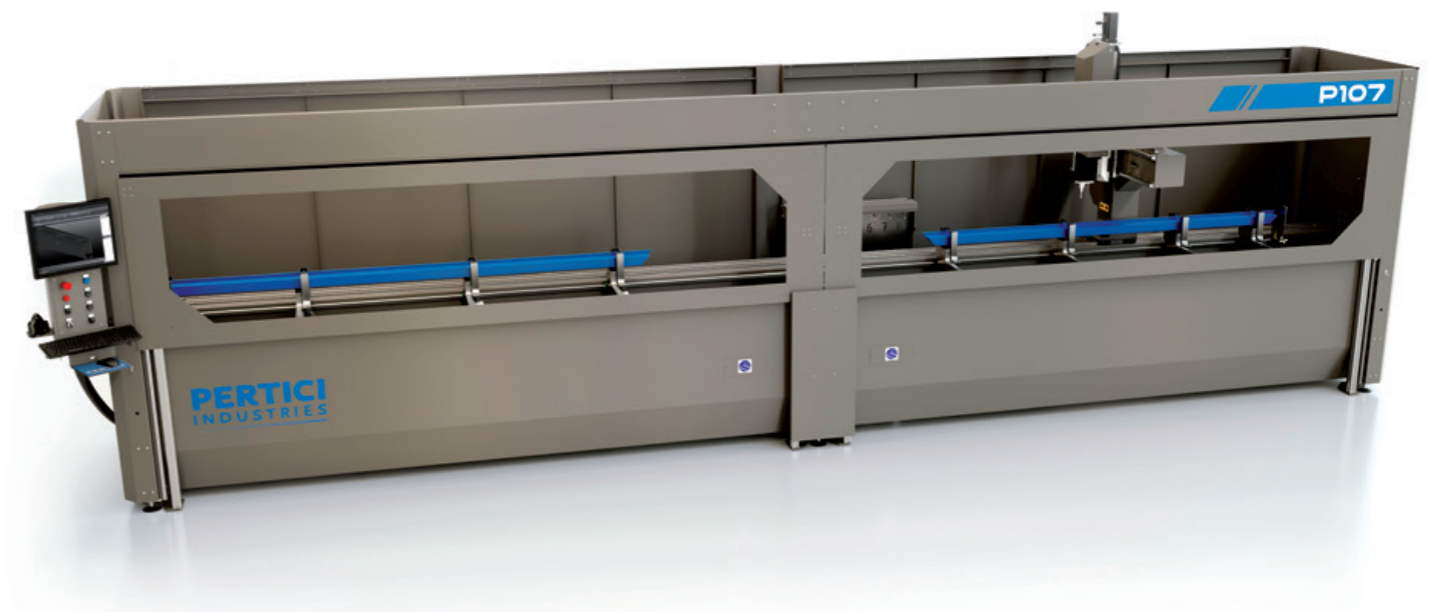
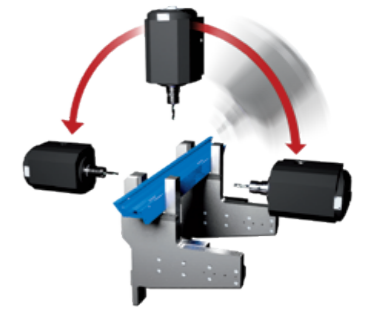

FC 1000

FC1000 is a CNC working and automatic screwing line. It consists of a profile loading magazine, a central multi-spindle ring module and an unloading magazine. The production cycle of the machine allows to execute in sequence all the working, screwing, drilling and milling phases. The profile is moved by a motorized gripper that slides on the unloading magazine, adjustable in width and height, hooks the profile and brings it to the working area.

Seven electro spindles and a screwdriver are installed on the 4-axis CNC milling module, allowing work to be carried out on the entire contour of the workpiece, however it is oriented, allowing work to be carried out with precision and ensuring that it can be removed from the fully machined outfeed magazine.

The loading magazine has a capacity of 10 bars and the machinable section is 130 mm in width by 120 mm in height. The length of the profile ranges from a minimum of 350 mm to a maximum of 4000 mm. The working unit is equipped with soundproofing cabin of the central operating part which, in addition to protecting the operator, allows to reduce the environmental acoustic impact.

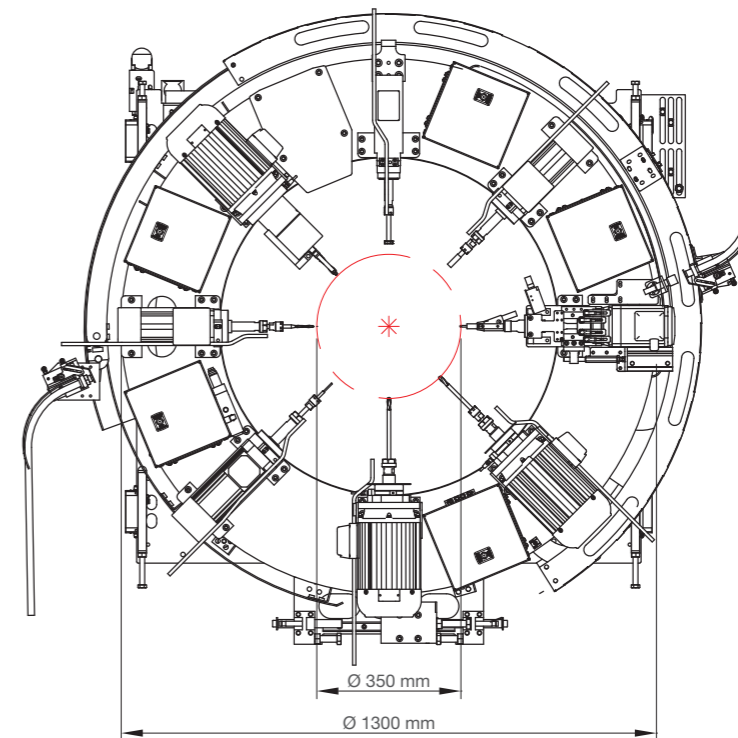
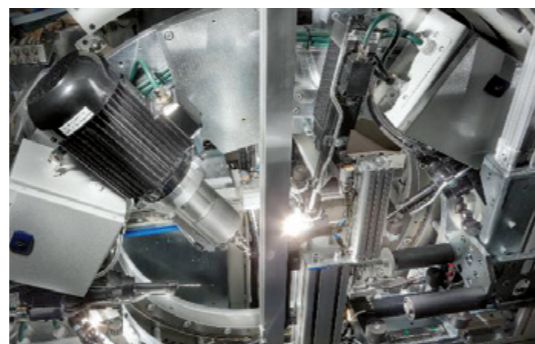
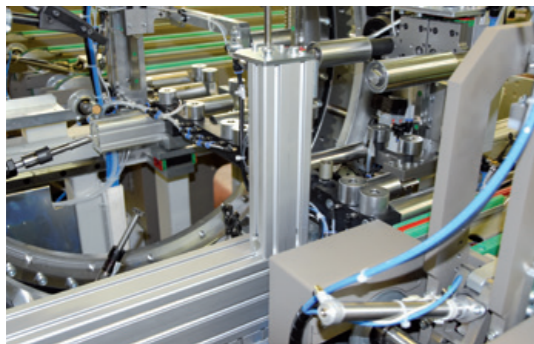
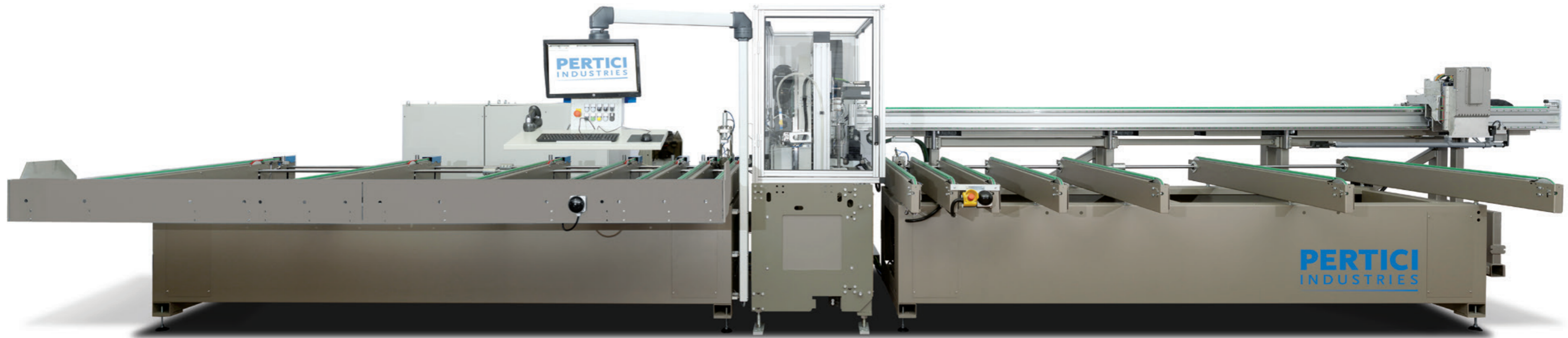



MACHINING CENTERS SOFTWARE //

Pertici Industries' software products are the link between the operator and the machines. They have been developed with the aim of facilitating all the operations of man/machine interface, generation of working lists for cutting centers and double head saws, macro generation for machining centers. They allow to carry out final simulations to verify and calculate working times and interface with the software of other companies.

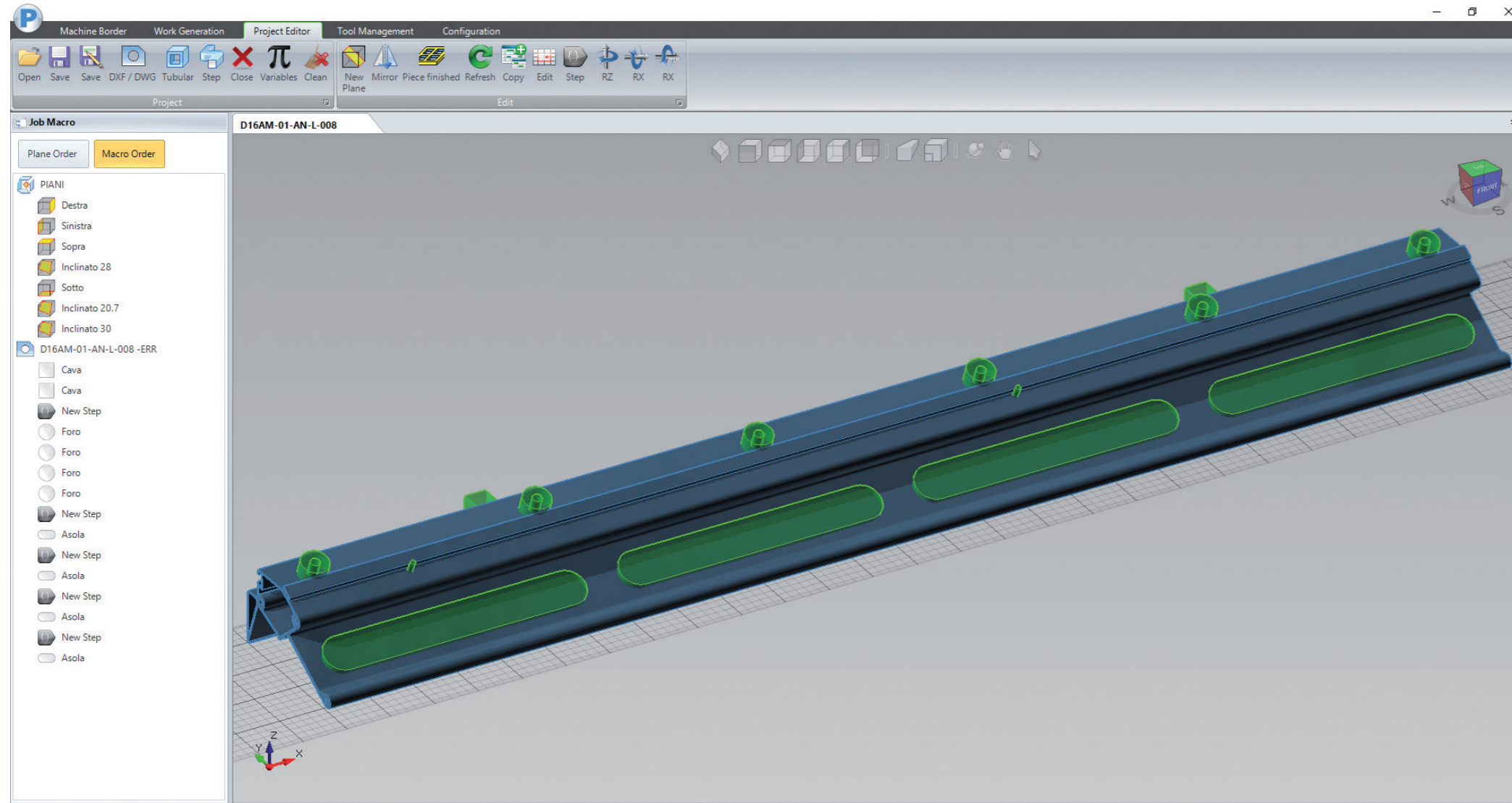

Pertici Industries CAD/CAM platform has been designed to manage the entire job order, from 3D design to production.

The Software Suite of the "P" series was created to help technicians and operators to develop small and large work orders with Pertici Industries CNCs. The use of these software allows to obtain excellent results in terms of machine cycle and machining time.

The range consists of four applications, all complementary and integrated:

- P-CAM
- P-SIMULATION
- P-REPORT
- P-INTERFACE

Their ease of use and integration make it possible to graphically define all drilling, milling, cutting operations and move in short steps to the actual production phase.

Thanks to a simple programming logic, the operations to be performed by the operator are extremely easy.

P-CAM

P-CAM is a 3D software for graphically programming machining operations. It includes the most recurrent machining patterns (holes, slots, rectangular slots, locks, etc.), management of the disc cutter, tapping cycles and creation of free patterns, as well as all tool management and vice positioning with relative anti-collision.

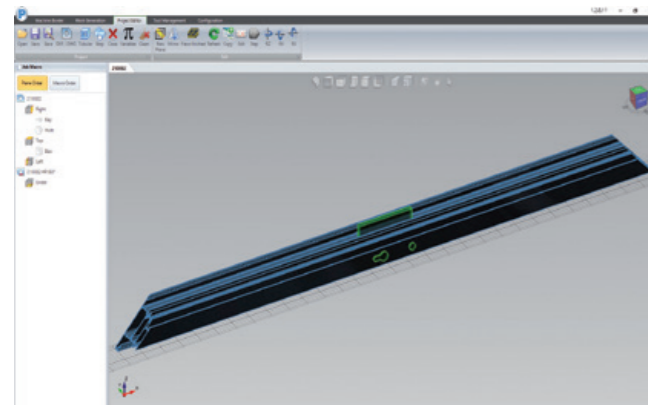

P-SIMULATION

P-SIMULATION performs the simulation of the work cycle without engaging the machine. With this software the operator can go to act on tool paths and tool management to optimize cycle times.

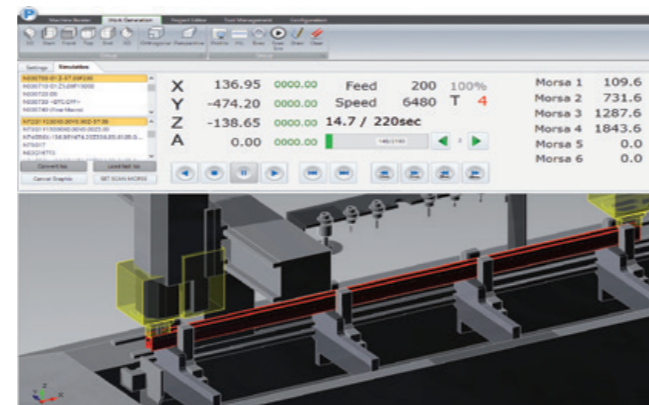

P-REPORT

P-REPORT performs a recording of all machine functions, specifically analyzing the distance travelled by the axes, the working time of the electro spindle, the number of programs etc. Thanks to this software a basic diagnosis is also implemented for the management of ordinary maintenance.

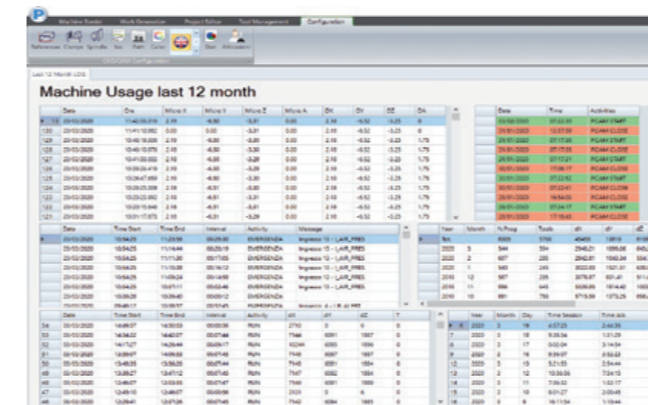

P-INTERFACE

P-INTERFACE is a program that manages the connection of machining centers to third party software. It then manages the input of information and transforms it into machine language for profile machining.

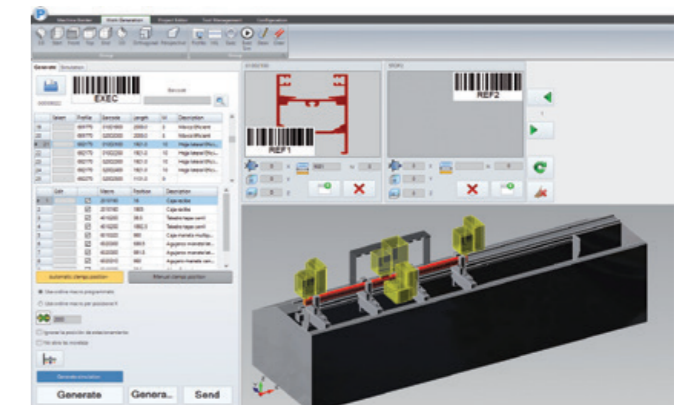

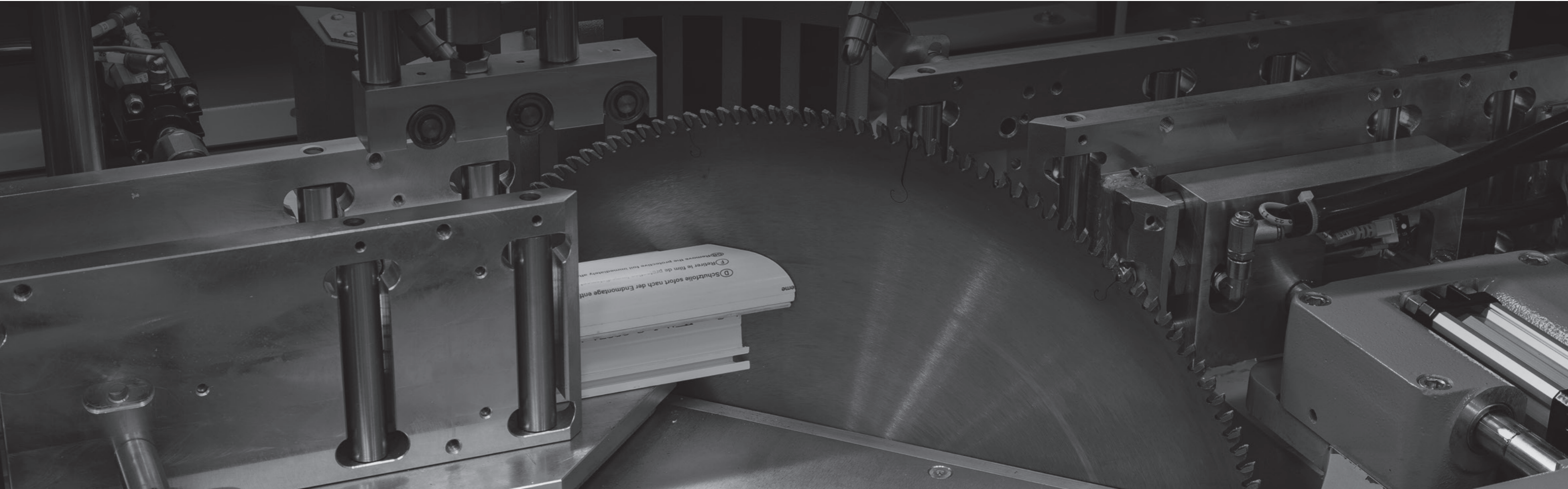

CUTTING CENTERS //

CNC cutting centre with 1 controlled axis is designed for cutting PVC profiles with maximum cutting speed and highest quality. The machine performs the operation of profile loading from the bars stock, cutting and unloading of piece, in complete autonomy and without the assistance of the operator.

The working direction is available according to the customer needs either from left to right and viceversa. The software, developed entirely by Pertici Industries, ensures the better management of the working cycle and the cutting lists automatically interfacing with the main cutting list processing programs available on the market.

SC 55
SC 65

CNC cutting Center with 1 controlled axis, designed to cut PVC profiles with the highest cutting speed and quality. The machine loads the profiles from the bar stock magazine, cutting and unloading the part, in complete autonomy and without the assistance of the operator. The working direction is available according to the customer's needs, from left to right and vice versa. The software, developed entirely by Pertici Industries, ensures better management of the work cycle and cutting lists, automatically interfacing with the main cutting list processing programs available on the market.

The automatic bar loading unit has a capacity of up to 12 bars with a maximum length of 6.6 m. and is equipped with a bar presence detection device. Thanks to the position of the belts, short lengths of up to 400 mm can be loaded. The cutting unit with \varnothing 600 mm blade (SC 65) and \varnothing 500 mm blade (SC 55) cuts at three main angles, 45° - 90° - 135°.

The profile is clamped during cutting by a special centering device which allows the blade center of rotation to be positioned in the center of the profile section, so that wedge cuts can also be made automatically. The cutting unit is fully enclosed with front door for free access to the cutting area for calibration, cleaning and maintenance purposes. In the rear part, the center is equipped with a special evacuation system for waste and cutting chips. The automatic unloading unit places the cut pieces in a special storage bench equipped with safety photocell with a capacity of 12 pieces (intermediate degrees available as option).

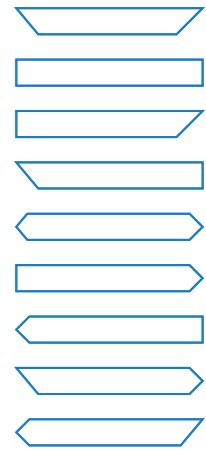

Cutting type

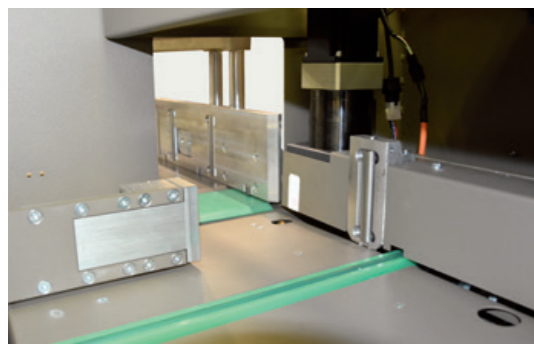
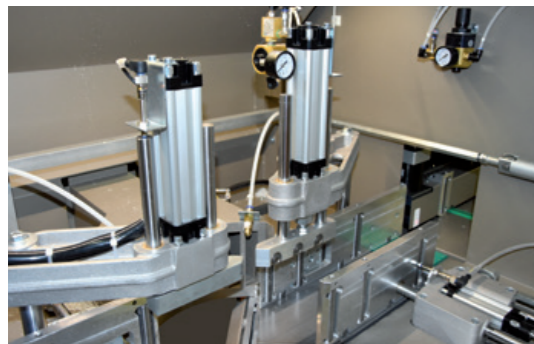

SC 55

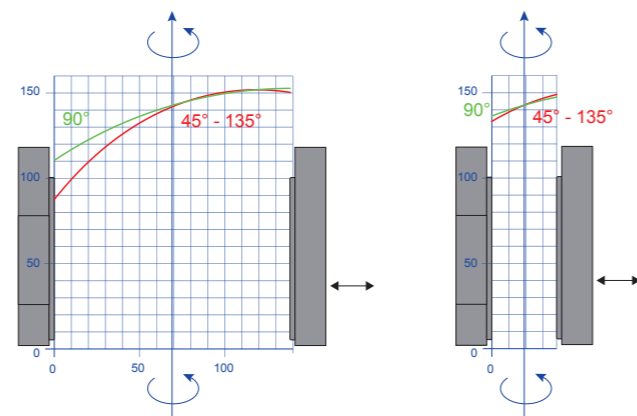

SC 65

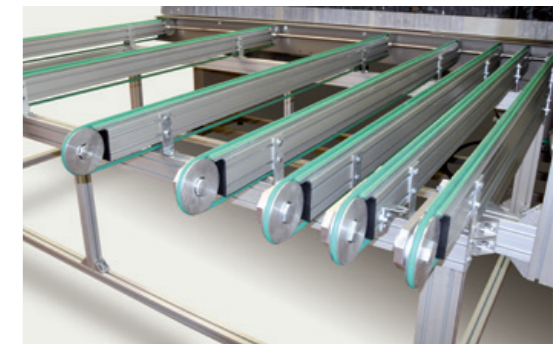
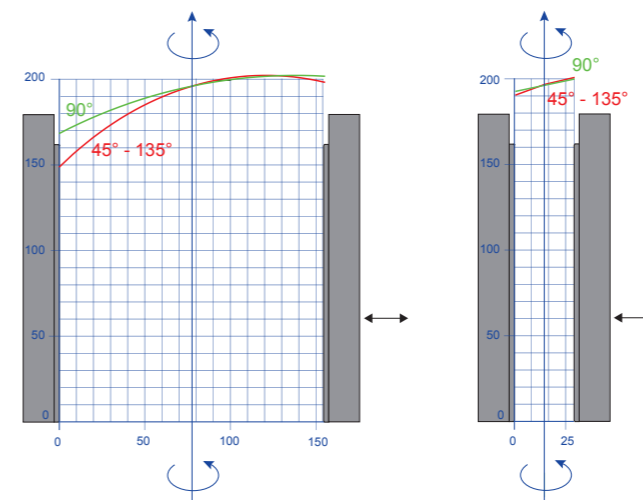

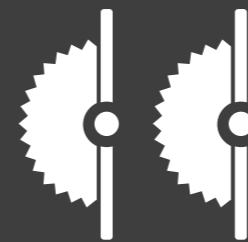
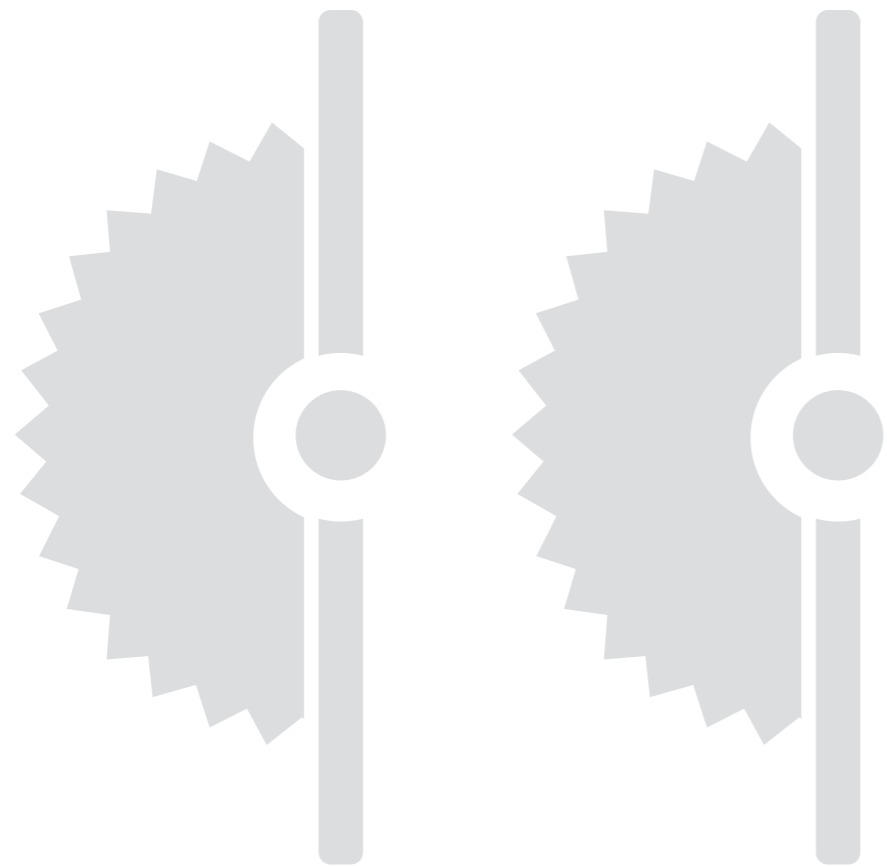
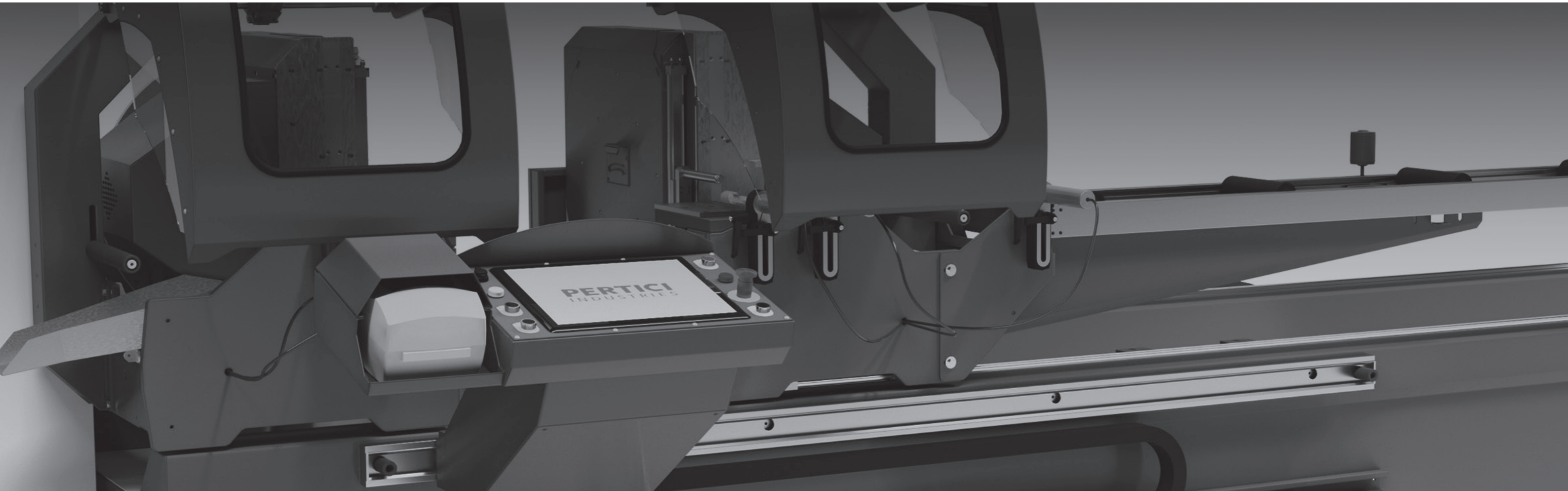

DOUBLE HEAD CUTTING MACHINES //

The double-head cutting-off machines are used for cutting aluminum, PVC and light alloy profiles, ideal for mass production and special applications as they guarantee great reliability. The present Series, provided with high rigidity, are equipped with two independent cutting heads, one fixed and the other mobile, which operates in two different ways:

- automatically by means of an AC motor with magnetic ruler control system (electronic machines);
- manually with magnetic ruler control system (semi-automatic machines).

All movements are performed on bars and linear guide rails (equipped with recirculating ball bearings the 500- 600 series). These features make it possible to cut all types of profiles, even large ones, with centesimal precision, thanks to a wide range of models equipped with blades from 330mm to 660mm diameter.

600 TSE

600 TSE is a double-head cutting-off machine with controlled axes and 600 mm Ø blades, the machine consists of three main structures, a robust electro-welded steel base with a fix cutting unit and a mobile cutting unit that slides along the base with electronic positioning (X-axis). The rotary axes of both Fix and Mobile heads allow the cutting units to tilt at an angle from 45° (internal) to 20° (external). The blade feed is driven by an oil-pneumatic cylinder with output speed regulator and quick return.

Thanks to a horizontal clamping system with double cylinder and a vertical clamping system, the perfect clamping of any type of profile is ensured. The pneumatic protections isolate the operating units during the cutting phase, ensuring excellent protection and easy use of the machine. 600 TSE is a latest generation machine that can be easily integrated in the production cycle with remarkable ease of use thanks to the 15" touch screen monitor on Windows Embedded platform, which allows to easily program all cutting operations.

The machine can be equipped with an industrial label printer that allows its identification and association to the relevant job order.

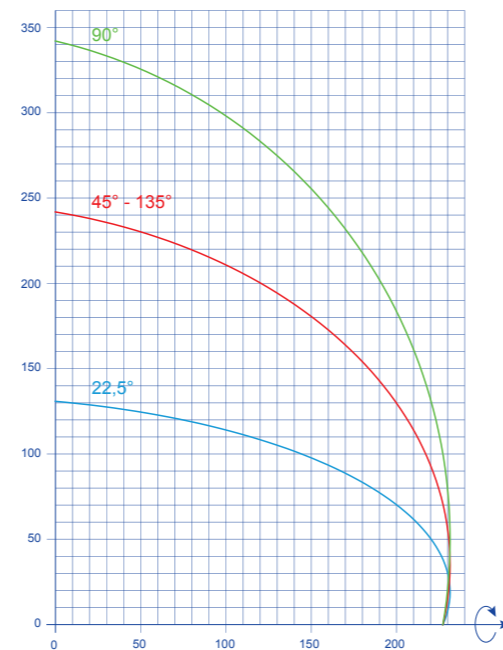
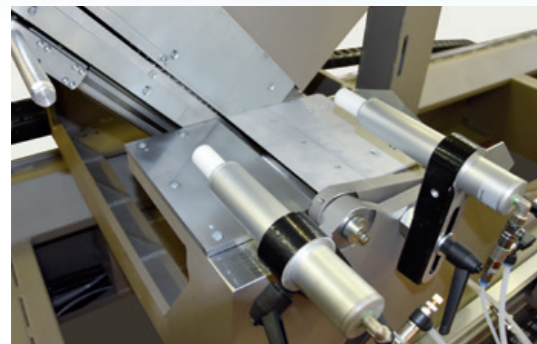
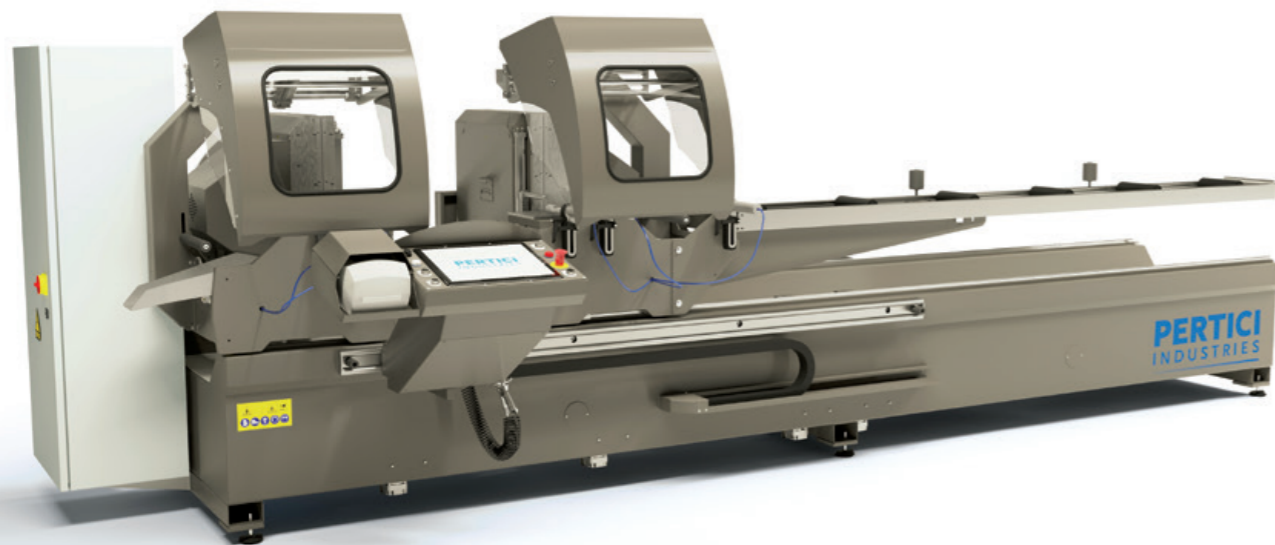
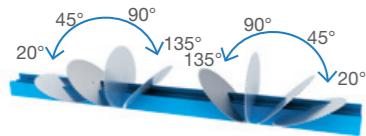

550 TSE is a double-head cutting-off machine with controlled axes and 550 mm Ø blades, the machine consists of three main structures, a robust electro-welded steel base with a fix cutting unit and a mobile cutting unit that slides along the base with electronic positioning (X-axis). The rotary axes of both Fix and Mobile heads allow the cutting units to tilt at an angle from 45° (internal) to 20° (external). The blade feed is driven by an oil-pneumatic cylinder with output speed regulator and quick return.

Thanks to a horizontal clamping system with double cylinder and a vertical clamping system, the perfect clamping of any type of profile is ensured. The pneumatic protections isolate the operating units during the cutting phase, ensuring excellent protection and easy use of the machine. 550 TSE is a latest generation machine that can be easily integrated in the production cycle with remarkable ease of use thanks to the 15" touch screen monitor on Windows Embedded platform, which allows to easily program all cutting operations.

The machine can be equipped with an industrial label printer that allows its identification and association to the relevant job order.

550 TSE

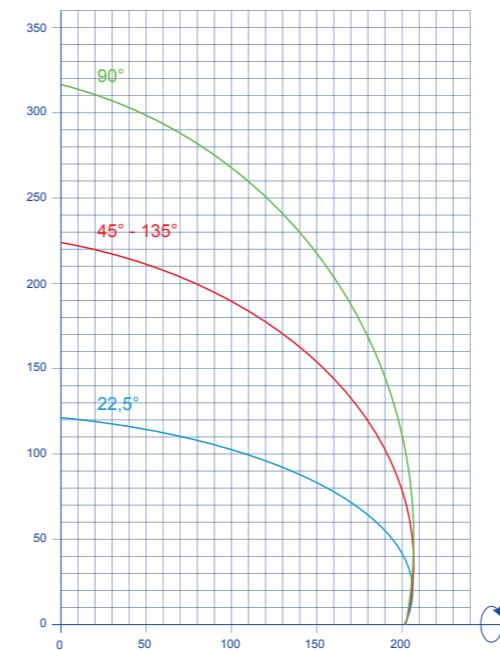
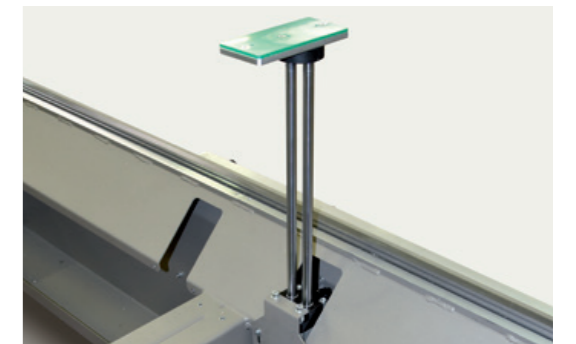
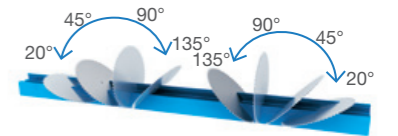

500 TSE

500 TSE is a double-head cutting-off machine with controlled axes and blade Ø 500 mm, the machine consists of three main structures, a robust electro-welded steel base with a fixed cutting unit and a mobile cutting unit that slides along the base with electronic positioning (X-axis).

The rotary axes of both Fix and Mobile heads allow the cutting units to tilt at an angle from 45° (internal) to 20° (external). The blade feed is driven by an oil-pneumatic cylinder with output speed regulator and quick return. Thanks to a horizontal clamping system with double cylinder and a vertical clamping system, the perfect clamping of any type of profile is ensured.

The pneumatic protections isolate the operating units during the cutting phase, ensuring excellent protection and easy use of the machine. 500 TSE is a latest generation machine that can be easily integrated in the production cycle with remarkable ease of use thanks to the 15" touch screen monitor on Windows Embedded platform, which allows to easily program all cutting operations.

The machine can be equipped with an industrial label printer that allows its identification and association to the relevant job order.

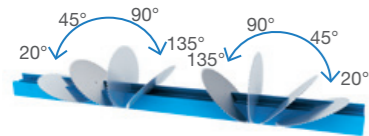

500 TS, 500 CD and 500 D2K are automatic double head cutting-off machine with pneumatic head rotation. The machines consist of three main structures, a sturdy electro-welded steel base with a fixed cutting unit and a mobile cutting unit that slides along the base with electronic positioning (X-axis).

The heads rotate around the horizontal axis by means of pneumatic cylinders. The angles that can be obtained are from 90° to 45° external (standard version) and angles from 90° to 22°30' external in the /22 version. The intermediate angles are obtained by means of a manually adjustable stop. The blade feed is driven by an oil-pneumatic cylinder with output speed regulator and quick return.

Thanks to a horizontal clamping system with double cylinder and a vertical clamping system, the perfect clamping of any type of profile is ensured. The pneumatic protections isolate the operating units during the cutting phase, ensuring excellent protection and easy use of the machine. 500 TS, 500 CD and 500 D2K are the latest generation machines that can be easily integrated in the production cycle thanks to the various man/machine interfaces both touch screen and alphanumeric keyboard and allow to easily program all the cutting operations.

The machines can be equipped with an industrial label printer that allows their identification and association with the relevant job order.

500 TS 500 CD 500 D2K

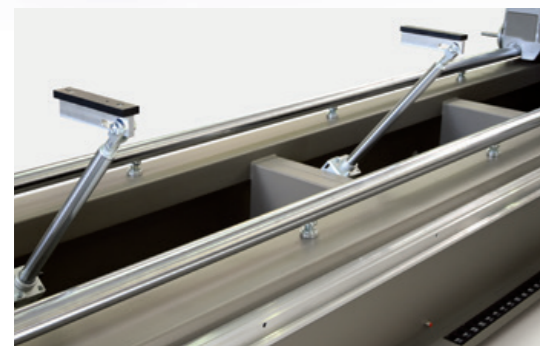
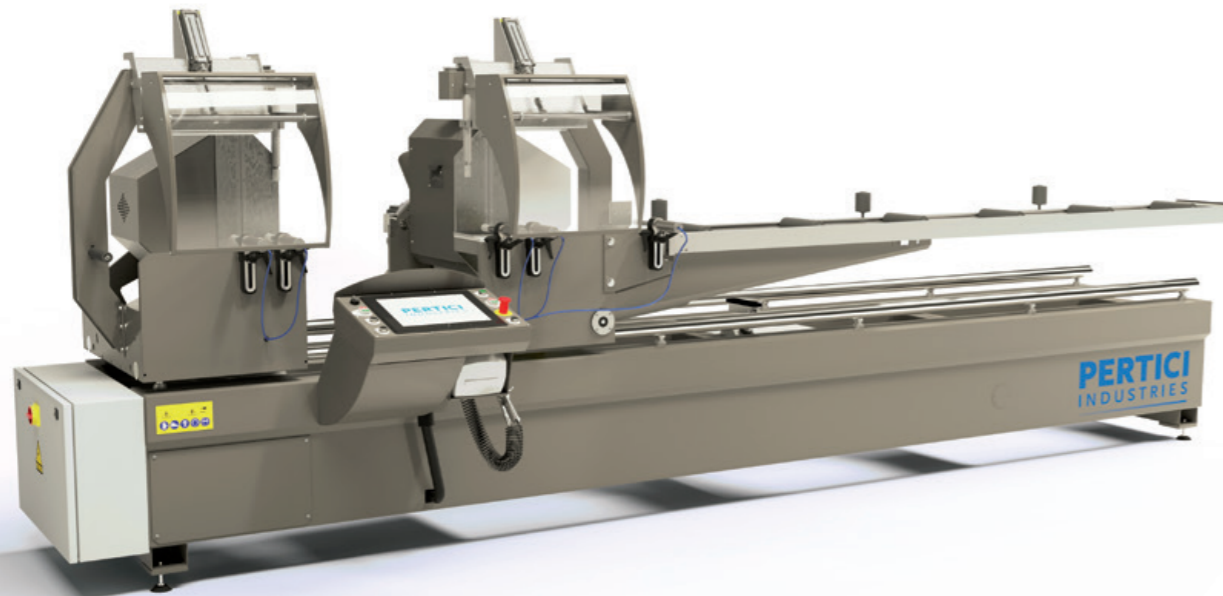
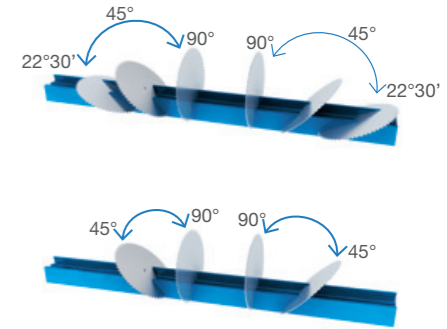

500 TSE
500 TS

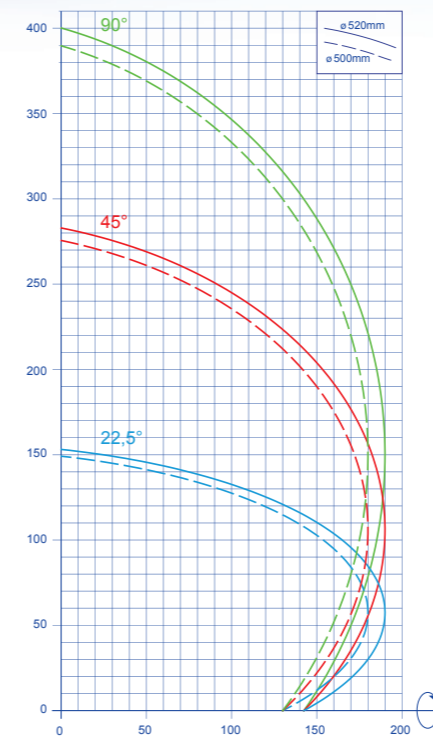
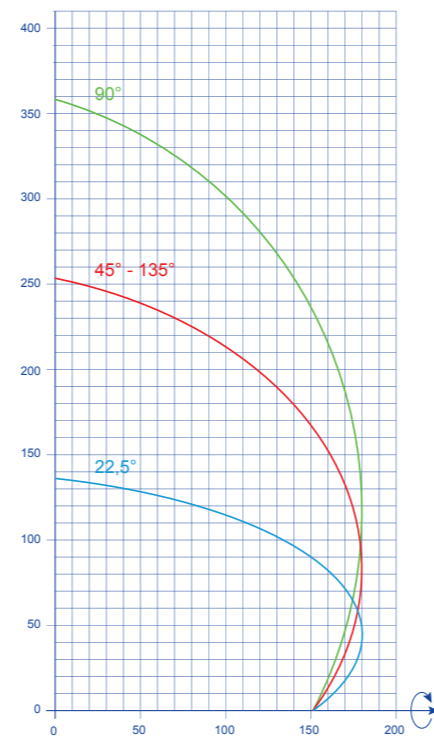

500 CD



500 D2K

402 IP
403 IP

402 IP and 403 IP are double-head pendulum cut-off machine with descending blade movement. These machines are featured by a combined blade movement that integrates the vertical rotation of the table from -45° to $+45^\circ$ manual and a vertical rotation from 90° to 45° external.

The horizontal and vertical clamping system ensures perfect clamping of the profile. The cutting units with blade d.400 mm are driven by pneumatic cylinders, three are the maximum cutting lengths, 3,5 m, 5 m, 6 m.

In the 402 IP version the moving head is manually operated, the cutting length is managed by a decimal metric ruler.

In the 403 IP version the moving head is with controlled axis and gives the possibility to manage cutting sizes and profile data storage.

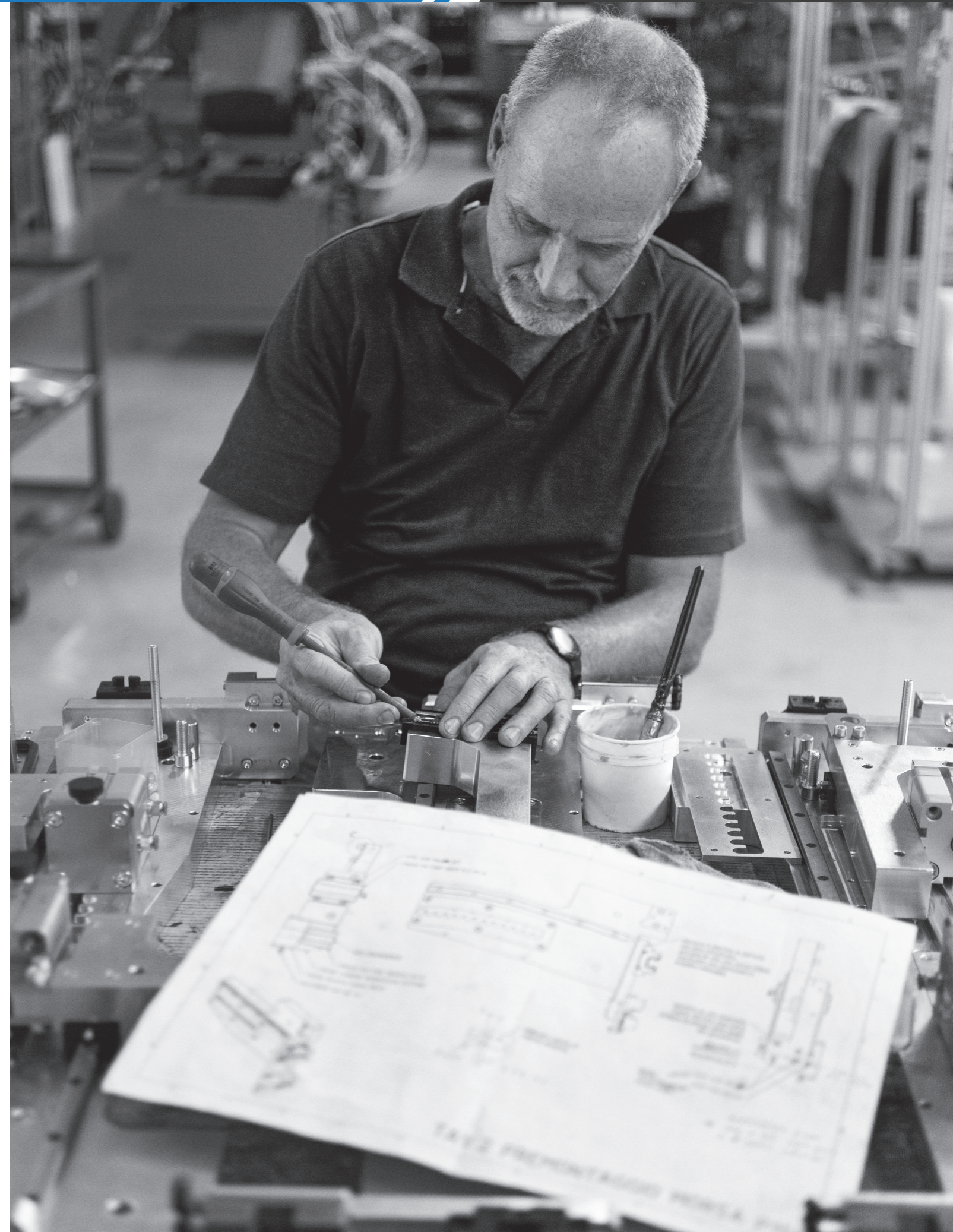
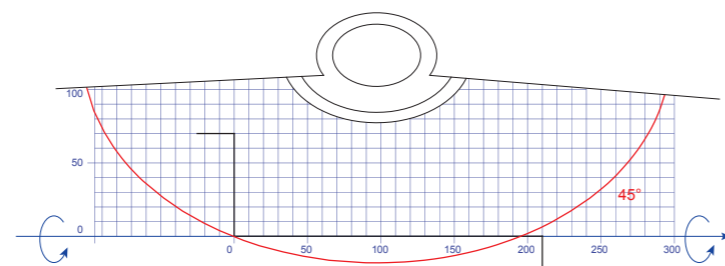
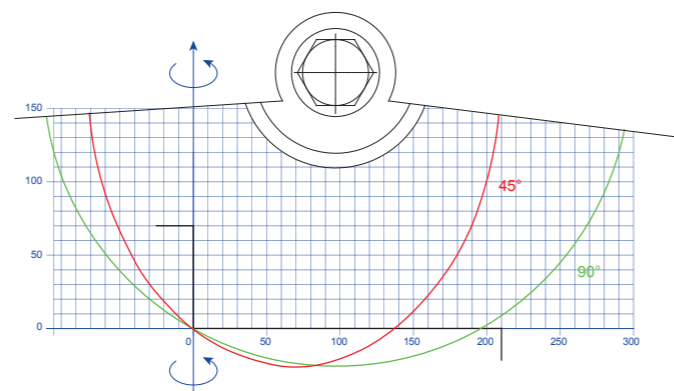
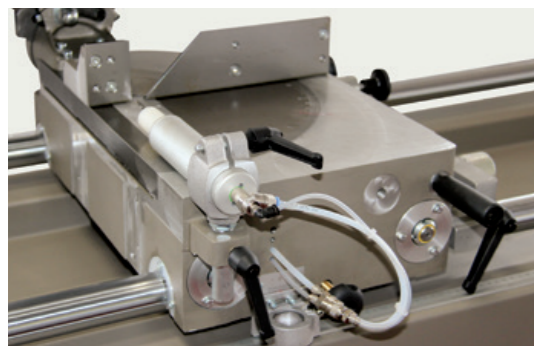

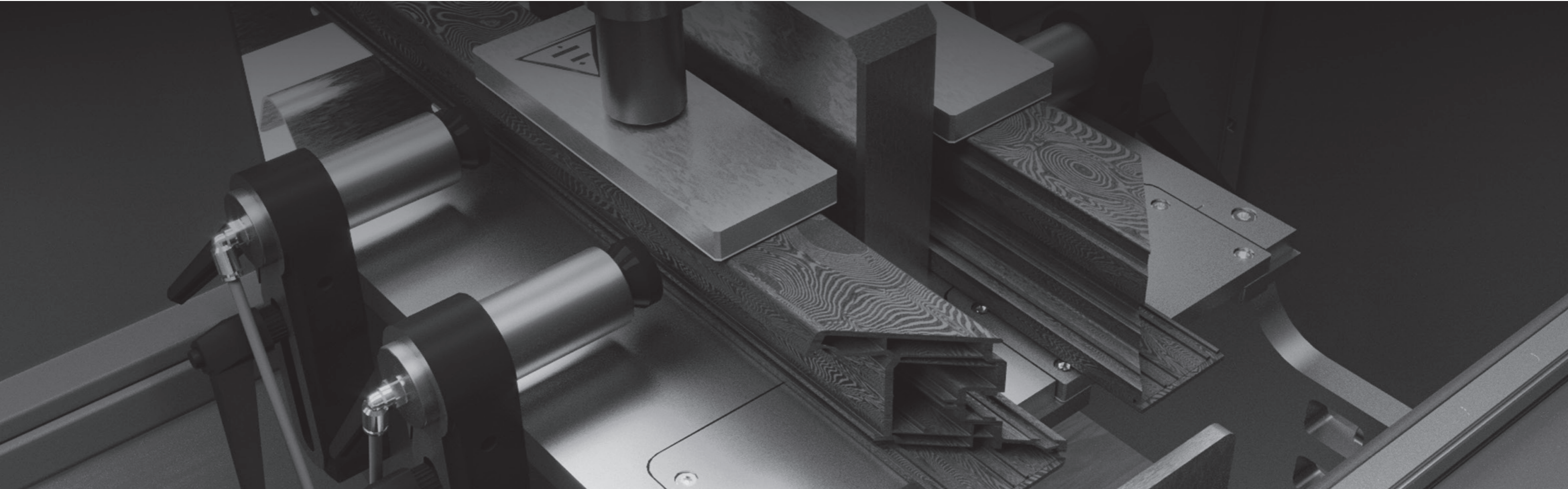

CNC END MILLING MACHINES //

WLS

The CNC end milling machine WLS has been designed to perform specific milling operations on PVC profile edges. The peculiarity of these operations allows to obtain an innovative angle coupling by re-proposing the jointing of the wooden frame at 90°. The aesthetic effect is also combined with the advantage of no longer having to carry out cleaning on this side since the coupling itself is finished after the normal welding operation.

The profiles are clamped in pairs in two special clamps where they are machined as mullions and transoms, the different types of machining are managed by a series of shaped tools housed on a special tool magazine.

The machine can manage the end machining both on the internal and external side according to the needs of the customer.

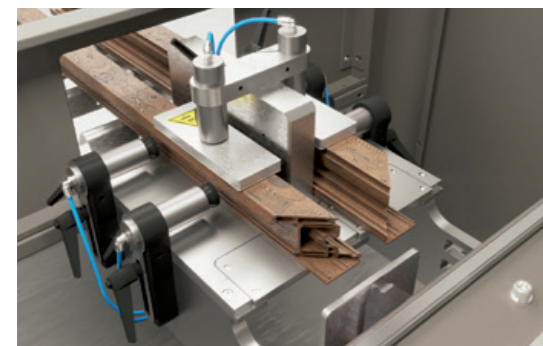

P45

The P45 CNC end milling machine has been designed to perform a partial contouring operation on the profile head. This operation allows to prepare the profile for the next welding operation with the result of obtaining a seamless fusion. Thanks to its 3 interpolated axes and a specially shaped milling cutter, the machine performs the milling following the profile shape previously loaded on the CAD-CAM. The machine can accommodate 4 profiles simultaneously in order to optimize cycle times.

Thanks to the powerful CAD-CAM that works on a 3D basis all the operations can be easily edited by configuring speed, feed and displacement parameters. The 3D graphics give back to the operator the real removal that the machine will then perform limiting programming errors and possible collisions.

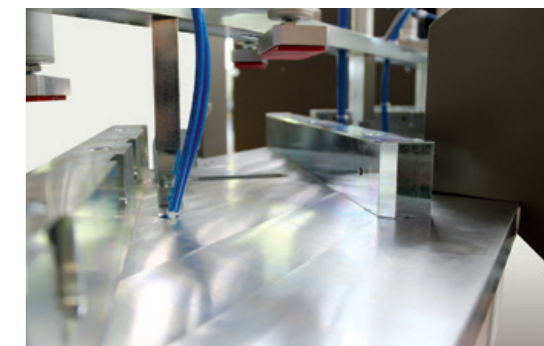

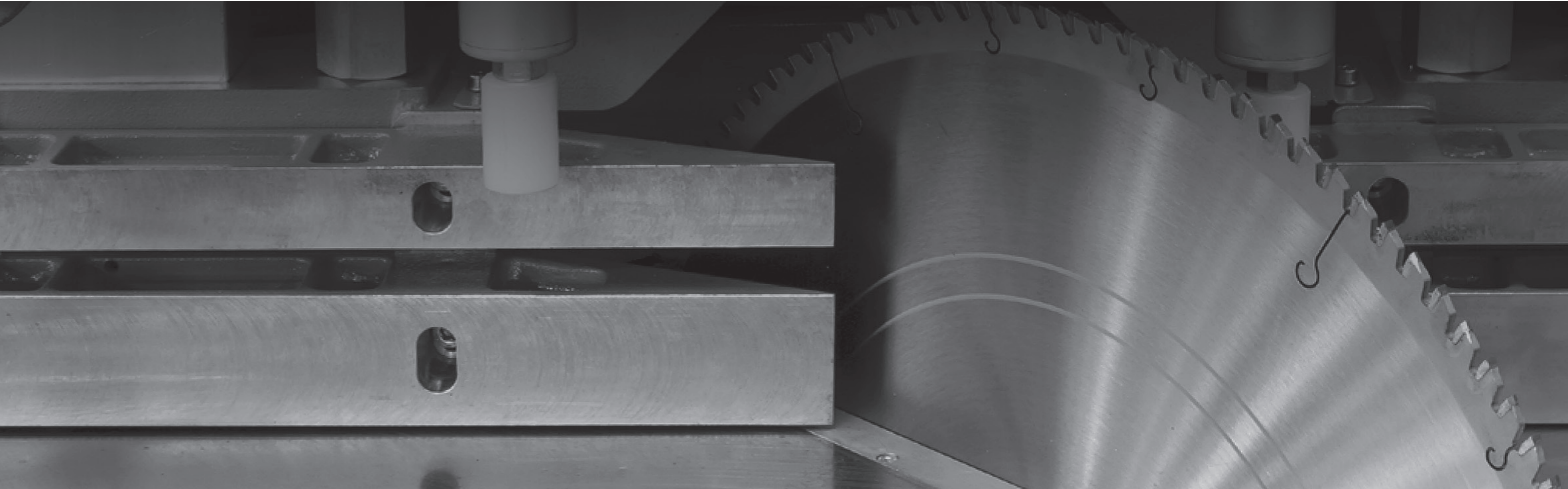

SINGLE HEAD CUTTING MACHINES //

The single-head cutting-off machines are designed for cutting PVC and/or aluminum profiles and similar materials. The present series of cutting-off machines are composed of various models, each one different from the other in terms of cutting system and blade diameter, up to 650 mm. These features, together with the sturdy built-in structure, allow to carry out precision cuts on profiles of various sizes.

CMPE 65

CMPE 65 is a single-headed rising blade cut-off machine for compound cuts. The profile support table rotates manually with angles ranging from $\pm 22.5^\circ$, the positioning of the cutting angle is managed by a magnetic ruler that uses a 10" touch screen monitor to display the dimension with centesimal precision.

The controlled horizontal axis integrated in the machine body rotates clockwise with an angle from 90° to 30° . The cutting saw is equipped with a 650 mm diameter widia blade, mounted on an oil-pneumatic feed system that guarantees uniform feed and thanks to the 5.5 kW motor, the power required for cutting profiles of important sections.

The control unit allows the total management of the machine's operating functions, both in terms of setting the cutting angles of the horizontal and vertical axes, as well as clamping the workpiece with a pair of horizontal and vertical clamps.



50 A and 50 AE are raising blade single-head cut-off machine with $\varnothing 500\text{mm}$ blade. The profile support surface rotates with angles ranging from $\pm 22.5^\circ$ and is available in the "A" (manual) version with 7 fixed angle stations, in the "AE" (electronic) version instead the head can be positioned at any degree. In the manual version, the angle reading for setting the intermediate degrees is guaranteed by a graduated line directly on the cutting table. In the electronic version the cutting angles are entered by means of a 7" Touch screen operator panel.

The sturdy steel and cast iron structure makes it ideal also for industrial cutting thanks to a blade motor with 4 kW power and minimal lubrication. Profile clamping is ensured by a pair of horizontal and vertical cylinders with high/low pressure system.

50 A 50 AE

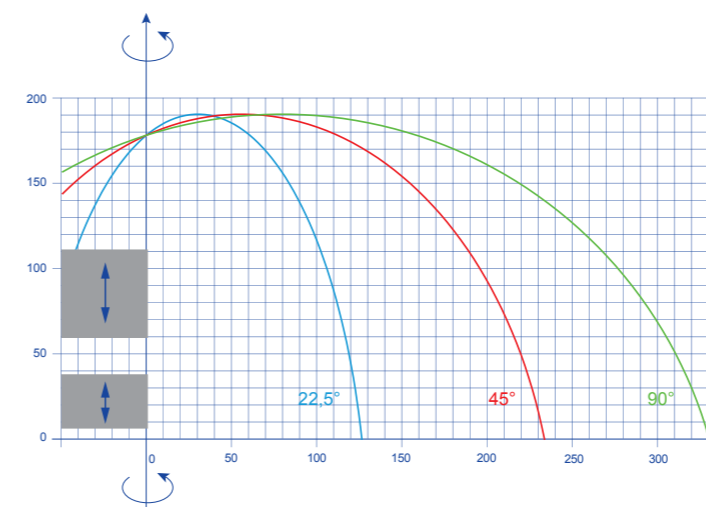
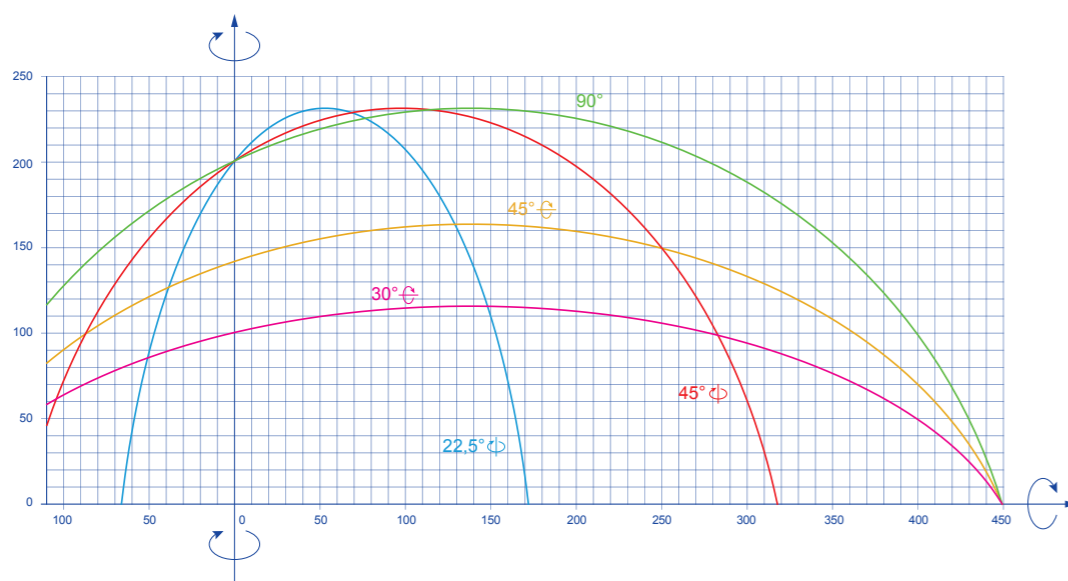

55 FS
55 FSE

The 55 series are single-head cutting-off machine with blade \varnothing 550 mm. The two versions are different for the rotation principle of the head.

On the 55 FS the inclination of the cutting unit is hydro-pneumatic with fixed angles at 20°, 45°, 90° right side and left side. The intermediate angles are managed by special hydro pneumatic regulators and the height is shown directly on the digital display.

On the 55 FSE the inclination of the cutting unit is electronically controlled by a linear actuator that guarantees very high positioning precision. In this way we can manage any cutting angle in the range from +/- 20°. In this version the cutting angles are inserted by means of a 7" Touch screen operator panel.

55 FS and 55 FSE are equipped with horizontal clamps for the correct clamping of the profile, minimal blade lubrication and integral protection of the cutting unit with pneumatic movement.

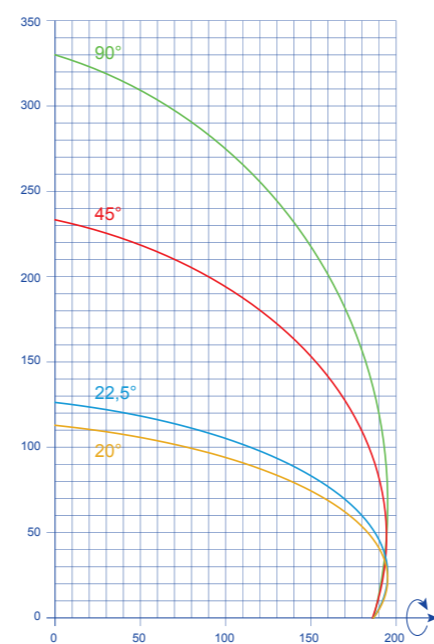
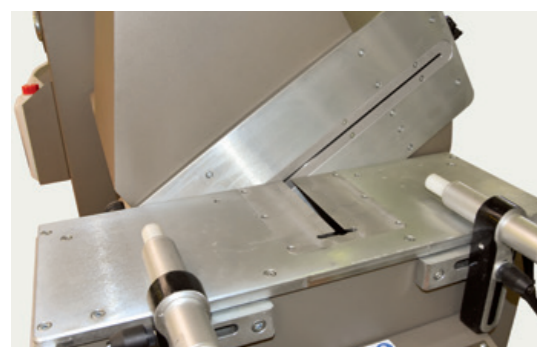

40 MP is a single-headed pendulum cut-off machine with descending blade \varnothing 400 mm. The profile support surface rotates manually at an angle of +/-45°, the manual side tilt of the head goes from 0° to 45° outside. 40 MP is equipped with horizontal clamps for the correct clamping of the profile, minimal blade lubrication and mechanical protection of the cutting area.

40 MP

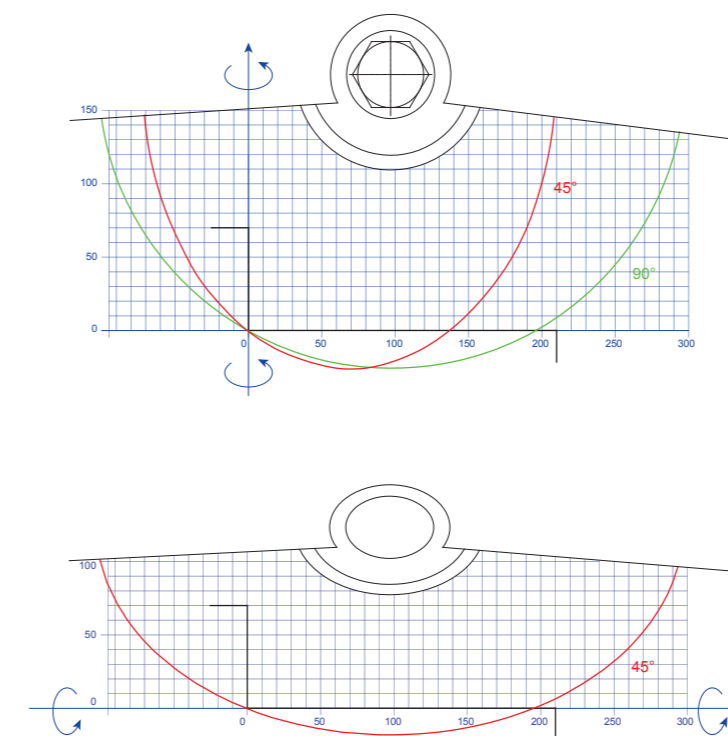

BS 772

BS 772 is a semi-automatic cut-off machine for cutting PVC glazing beads. The cutting system consists of two pairs of blades positioned at 45°. The 225 mm blade performs the cutting of the glazing bead, the 103 mm blade performs the internal beveling for hooking the glazing bead. The blade carriage is driven by a pneumatic cylinder, the profiles are clamped by two pairs of vertical clamps. BS 772 is equipped with a glass simulation system for two profiles with 12-position revolver stop and adjustment of the vertical clamps with 6-position revolver stop.

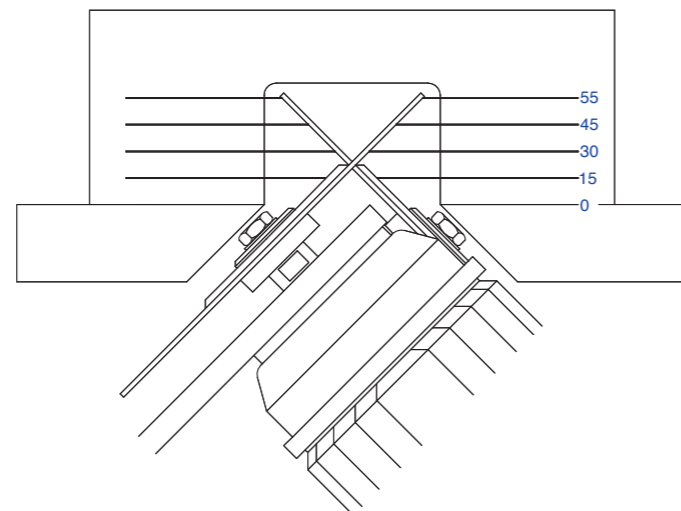
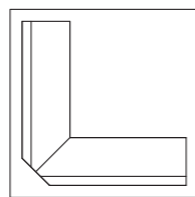
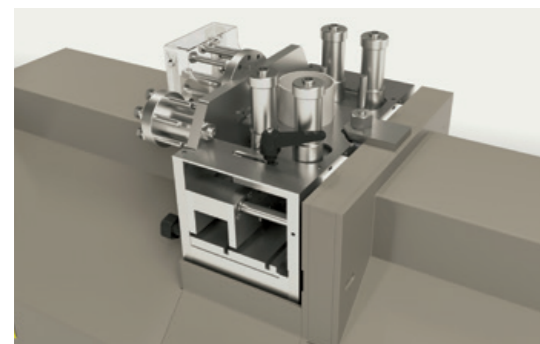

BS 773
BS 774

BS 773 and BS 774 are systems that integrate a variable angle cut-off saw combined with either an electronic measuring stop or a gripping system that transforms the profile support into a pusher. The cutting-off saw has a raising blade, the positioning of the rotary table is managed by numerical control and varies between 20° and 160°.

On the BS 773 and BS 774 with 300 mm cutting blade, the mechanical structure is specifically designed to cut PVC and aluminum glazing beads, equipped with a system of quick adjustment templates and a system that allows the processing of all profiles in a range without having to replace the tooling.

The profile support bench is made with strong aluminum profiles that integrate the sliding system of the trolley. The positioning of the stop or the pusher is managed by the numerical control with feedback from magnetic tape with maximum error of +/-0.1mm. The man/machine interface is managed by a 7" colour touch screen operator panel based on Windows CE. The support surface has a width of 220mm, and a length of 3000 mm.



BS 773 - BS 774

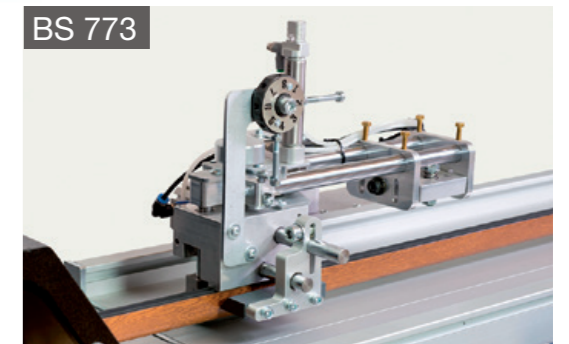
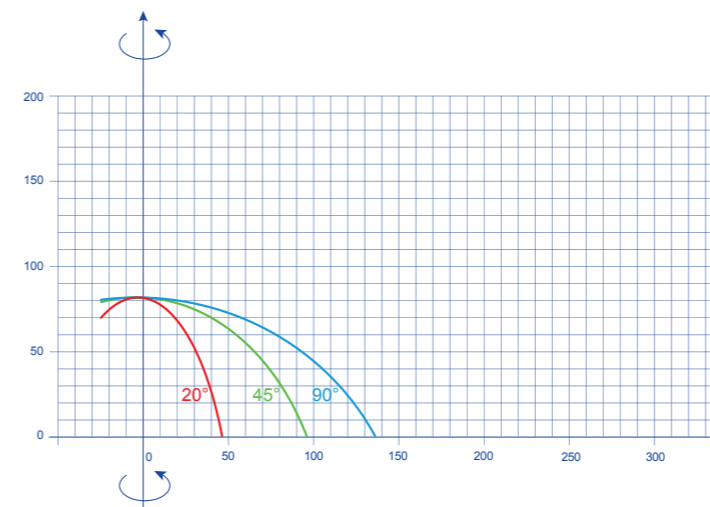

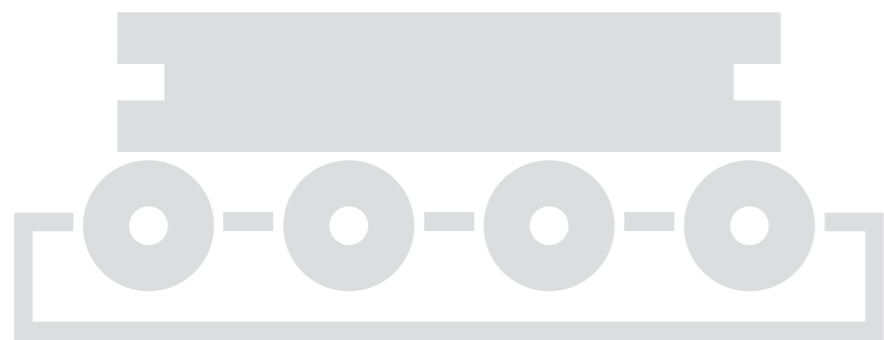
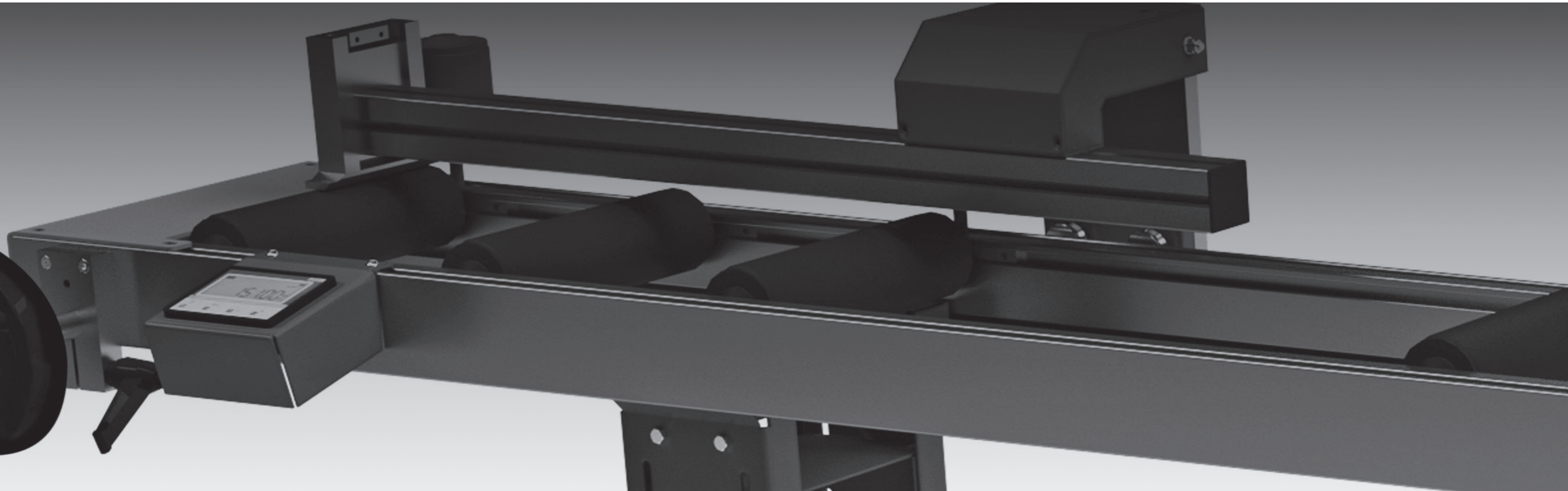

LENGTH STOPS AND ROLLER CONVEYORS //

VISUAL RF

Visual RF is an electronic and automatic outfeed length stop, combined with a cut-off machine it allows the accurate positioning of PVC and aluminum profiles or bars. The profile support is built with robust aluminum extrusions that integrate the sliding rail of the carriage. The positioning of the stop is carried out by a Stepper motor integrated in the carriage and is managed by an electronic control unit.

Thanks to the magnetic tape, it allows a positioning accuracy of 0.1 mm and allows the length stop to operate with high speed and precision. The support surface has a width of 220 mm, with four versions of length 3, 4, 5, 6 meters.

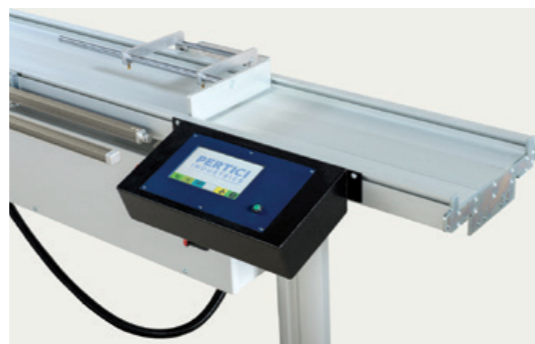

Visual EM is a manual unloading roller conveyor, the positioning of the zero stop is adjusted by a handwheel with digital display. The dimension detection is guaranteed by a magnetic ruler with decimal precision.

It is equipped with horizontal and vertical rollers and height adjustable feet. The support surface has a width of 220 mm, with four versions of length 3, 4, 5, 6 meters.

VISUAL EM

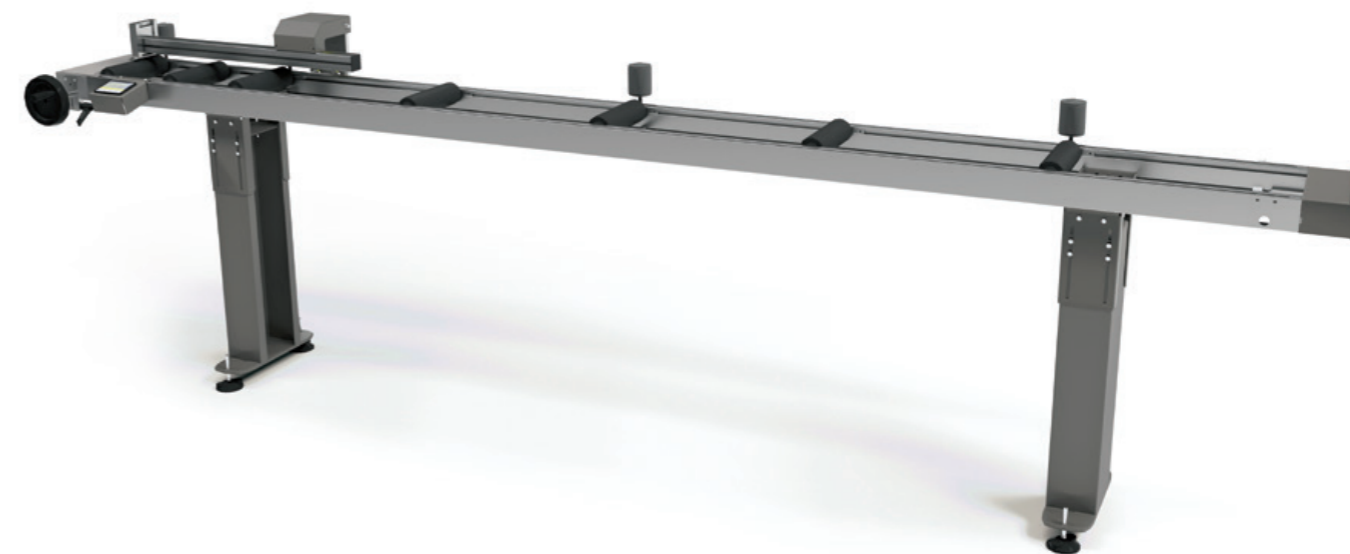

Roller is a loading roller conveyor with horizontal and vertical rollers for safe support of the profile. Extruded aluminum structure and adjustable feet. The support surface has a width of 220 mm, with four versions of length 3, 4, 5, 6 meters.

ROLLER

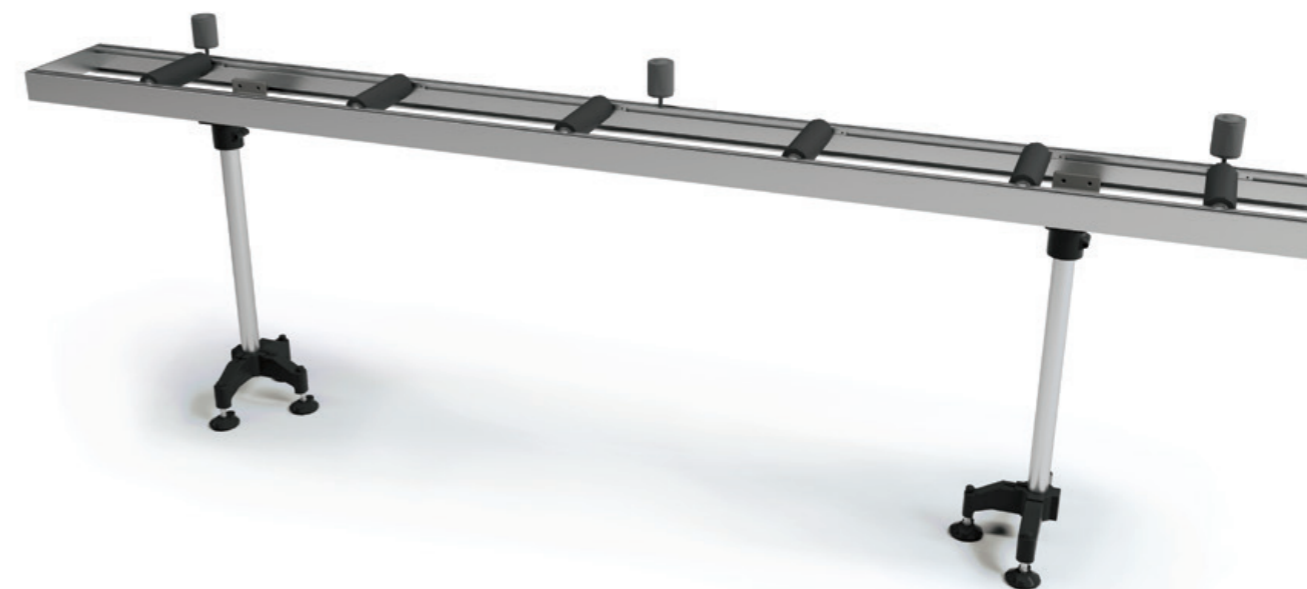



COPY ROUTERS END MILLING CRIMPING MACHINES //

CR 105

Manually-operated single-head copy router, head side movement with indirect lever. Axis movement on ball-bearing bars and bushes ensures smooth and precise operation over the years. Horizontal pneumatic clamps with low-pressure device for the operator's safety.

Longitudinal and transversal stops referred to metric rods and adjustable depth stop ensure quick positioning. Possibility of performing through operations without turning the piece. Manually-controlled tracer, tracer tip in level with 3-diameter tool. Micro-mist pneumatic tool lubrication (emulsified oil).



TECHNICAL DATA	CR 105
Three-phase power supply	380/400 Volt - 50/60 Hz
Three-phase motor power	0.75 kW
Spindle speed	12.000 rpm
X - Y - Z AXIS stroke	260 - 120 - 130 mm
Clamp capacity (bxh)	150x200 mm
Max cutter diameter	10 mm
Tracer tip diameters	6 - 8 - 10 mm
Weight	110 kg (242 lb)

CR 100

Manually-operated single-head copy router, head side movement with indirect lever. Ample height operating capacity. Axis movement on ball-bearing bars and bushes ensures smooth and precise operation over the years. Horizontal pneumatic clamps with low-pressure device for the operator's safety.

Longitudinal and transversal stops referred to metric rods and adjustable depth stop with 6 adjustable positions ensure quick positioning. Possibility of performing through operations without turning the piece. Manually-controlled tracer, tip in level with 3-diameter tool. Micro-mist pneumatic tool lubrication (emulsified oil).



TECHNICAL DATA	CR 100
Three-phase power supply	380/400 Volt - 50/60 Hz
Three-phase motor power	0.75 kW
Spindle speed	12.000 rpm
X - Y - Z AXIS stroke	310 - 120 - 175 mm
Clamp capacity (bxh)	175x230 mm
Max cutter diameter	10 mm
Tracer tip diameters	5 - 8 - 10 mm
Weight	125 kg (275 lb)

CR 106A

Manually-operated single-head copy router, head side movement with indirect lever and ample height stroke. Axis movement on ball-bearing bars and bushes ensures smooth and precise operation over the years. Featuring a 3-bit drilling unit for working handle-holes bolts with pneumatic control and hydraulic forward movement for working aluminium and PVC with steel reinforcement.

Horizontal pneumatic clamps with low-pressure device for the operator's safety. Adjustable depth stop and longitudinal and transversal stops referred to metric rods. Possibility of performing through operations without turning the piece. Manually-controlled tracer, tip in level with 3-diameter tool. Micro-mist pneumatic tool lubrication (emulsified oil).



TECHNICAL DATA	CR 106A
Three-phase power supply	380/400 Volt - 50/60 Hz
Three-phase motor power	0.75 kW
Spindle speed	12.000 rpm
X - Y - Z AXIS stroke	310 - 120 - 175 mm
Clamp capacity (bxh)	175x230 mm
Max cutter diameter	10 mm
Tracer tip diameters	5 - 8 - 10 mm
Three-phase bit motor power	1.1 kW
Bit spindle speed	900 rpm
Bit centre distance	21.5 mm
Adjustable bit height	15...65 mm
Weight	185 kg (407 lb)

CR 110

Manually-operated single-head copy router, pneumatic head downward movement locking and side movement by means of indirect lever. Axis movement on ball-bearing bars and bushes ensures smooth and precise operation over the years. The clamp plane rotation system permits quickly turning the piece by 90° without releasing the clamps. This device speeds up the jobs to be done on the two faces of the piece and makes them more precise. By means of through operations, up to four faces can be worked without releasing the piece.

Horizontal and vertical pneumatic clamps with low-pressure device for the operator's safety. Downward release with pneumatic control on grip Longitudinal and transversal stops referred to metric rods. The pneumatic tracer pit with pneumatic side movement, 6 adjustable settings and tip in level with 3 diameter tool permits quick and precise machine positioning. Button for locking the spindle during tool change. PVC clamp jaws adjustable without using spanners. Micro-mist pneumatic tool lubrication (emulsified oil).



TECHNICAL DATA	CR 110
Three-phase power supply	380/400 Volt - 50/60 Hz
Three-phase motor power	0.35 / 0.45 kW
Spindle speed two	6.000 / 12.000 rpm
X - Y - Z AXIS stroke	360 - 120 - 175 mm
Clamp capacity (bxh)	200x200 mm
Max cutter diameter	10 mm
Rotation of clamping table	0 / 90 degrees
Tracer tip diameters	5 - 8 - 10 mm
Weight	185 kg (407 lb)



ML 123

Manual-feed horizontal end-milling machine. Cutter unit pneumatic quick change. Performs milling operations, also off size between -45° and +45°. Fully protected work area. Scratchproof worktop. Forward movement on ball-bearing guides and runners ensures smooth and precise operation over the years. Self-braking motor and horizontal and vertical pneumatic clamps with low-pressure device making the machine particularly safe for the operator.

Revolver depth stop with 6 adjustable positions and micro-mist pneumatic tool lubrication (emulsified oil) speed up the work cycle. The integrated mill cutter magazine and conveyed shaving ejection make the machine tidy and clean.



TECHNICAL DATA	ML 123
Three-phase power supply	380/400 Volt - 50/60 Hz
Three-phase motor power	1.1 kW
Spindle speed	2.850 rpm
X AXIS stroke	300 mm
Clamp capacity (bxh)	200x120 mm
Max cutter diameter	160 mm
Cutter holder	Ø 27/32 mm - L 135 mm
Variable milling angle	-45°... +45°
Weight	125 kg (275 lb)

ML 124

Horizontal end-milling machine with manual or automatic feed in "A" version. The high tool rotation speed improves work quality on coated profile sections and off size. Performs milling operations, also off size between -45° and +45°. Cutter unit pneumatic quick change. Scratchproof worktop. Fully protected work area and ample internal visibility. Forward movement on ball-bearing guides and runners ensures smooth and precise operation over the years. Forward speed adjustment is hydraulic in the "A" version and the piece locking system is without approach stroke.

Horizontal and vertical pneumatic clamps with low-pressure device making the machine particularly safe for the operator. Revolver depth stop with 6 adjustable positions and micro-mist pneumatic tool lubrication (emulsified oil) speed up the work cycle. The integrated mill cutter magazine and the conveyed swarf ejection make the machine tidy and clean.



TECHNICAL DATA	ML 124
Three-phase power supply	380/400 Volt - 50/60 Hz
Three-phase motor power	1.5 kW
Spindle speed	6.000 rpm
X AXIS stroke	320 mm
Clamp capacity (bxh)	200x120 mm
Max cutter diameter	180 mm
Cutter holder	Ø 27/32mm - L 160mm
Variable milling angle	-45°... +45°
Weight	180-190 kg (396-418 lb)



ML 200

Horizontal end milling machine with automatic forward movement and work cycle. The high adjustable tool rotation speed with electronic variator is displayed on the LED digital display screen. This improves the quality of work done on painted profile sections and not at right angles. Performs milling operations off size between -45° and +45°. Cutter unit pneumatic quick change. Scratchproof worktop. Fully-protected soundproofed work area. Fully encased and plenty of internal visibility Forward movement on ball-bearing guides and runners ensures smooth and precise operation over the years.

The self-overturning stop ensures there is no contact between the stop and the piece during forward movement. Forward speed adjustment is hydraulic in the "A" version and the piece clamping system is without approach stroke. Revolver depth stop with 6 adjustable positions, Impulse tool lubrication (neat oil) and air-jet clamp plane cleaning speed up the work cycle. The integrated mill cutter magazine, the fume extraction connection setting and the swarf drawer make the machine clean and tidy. The manually-controlled soundproofed tunnel (only 90° milling) reduces noise levels to about 75 db.



TECHNICAL DATA	ML 200
Three-phase power supply	380/400 Volt - 50/60 Hz
Three-phase motor power	2.2 kW
Spindle speed	4.000...7.000 rpm
X AXIS stroke	350 mm
Clamp capacity (bxh)	200x120 mm
Max cutter diameter	200 mm
Cutter holder	Ø 27/32mm - L 160mm
Variable milling angle	-45°... +45°
Weight	260-300 kg (572-660 lb)

Horizontal cutting machine designed for cutting aluminum and PVC profiles. Adjusting the blade rise and full blade protection, with internal visibility, place the highest level of safety for the operator.

Equipped with a pneumatic tool cooling system by micro-fog. The wide working surface of electrolytically ground steel is smooth, chip-free and rustproof.

RF 350



TECHNICAL DATA	RF 350
Three-phase power supply	380/400 Volt - 50/60 Hz
Three-phase motor power	1.5 kW
Spindle speed	2.850 rpm
Max cutter diameter	350 mm
Weight	150 kg (330 lb)



RF 3000

RF 3000 is a machine designed to trim PVC and Aluminum frames and profiles in a single step leaving the fixed piece on the workbench. The operator can in fact process large frames in total autonomy and safety. Normally placed at the end of the welding and cleaning process, the trimming machine is suitable for both small and large productions and can be used for hardware assembly operations, quality control, etc.

This model provides an automatic profile clamping system with combined action that ensures the perfect positioning of the frame. The positioning of the cutting dimension is controlled by a manual handwheel (optional with automatic positioning) equipped with a decimal numerical indicator. The blade feed is guaranteed by a gear motor with pinion/rack transmission (optional with inverter to control the blade feed speed). The cycle is activated automatically once the clamps are closed, the frame is clamped and two start buttons are pressed.

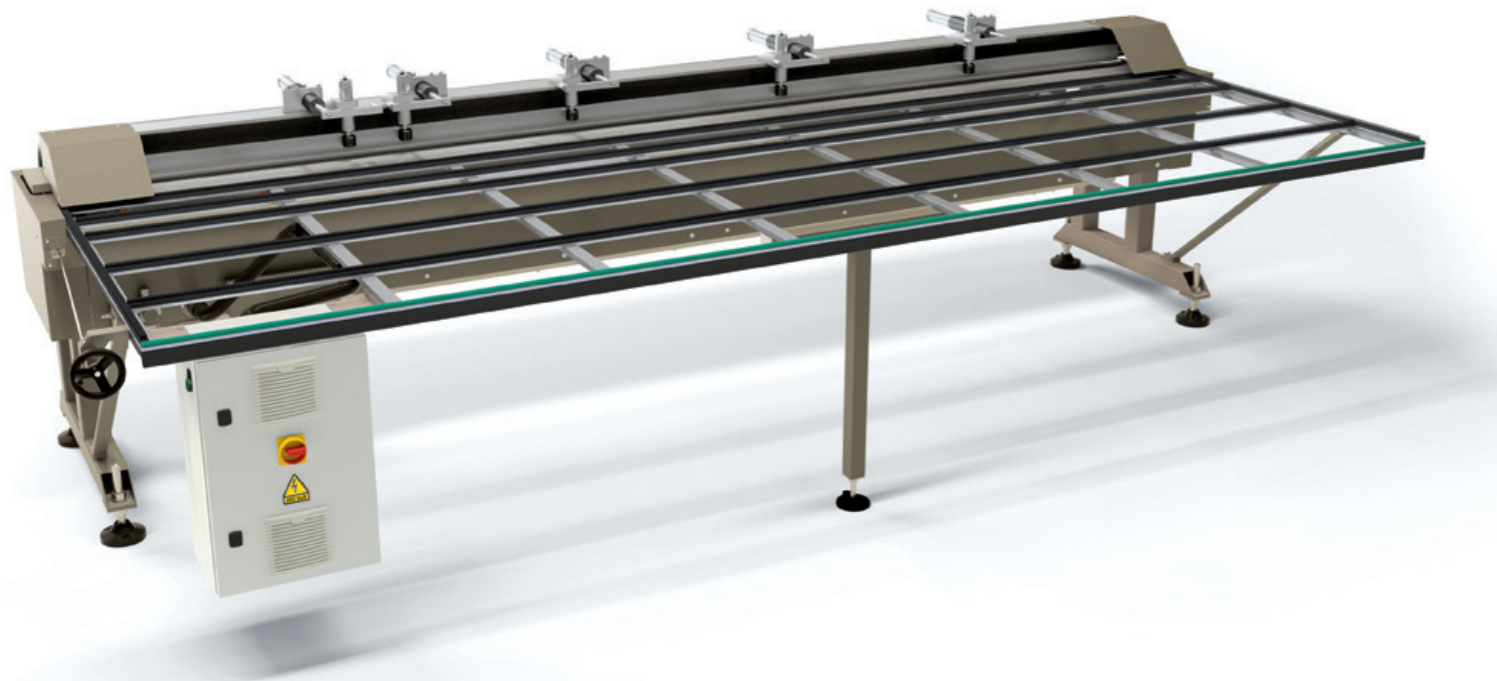

TECHNICAL DATA	RF 3000
Three-phase power supply	380/400 Volt - 50/60 Hz
Three-phase motor power	1.5 kW
Spindle speed	2.800 rpm
Maximum diameter of the blade	300 mm
Max. Cutting stroke	3.000 mm
Air pressure	6-8 bar
Dimensions (WxDxH)	3.960x2.000x1.300 mm
Weight	460 kg (1.014 lb)

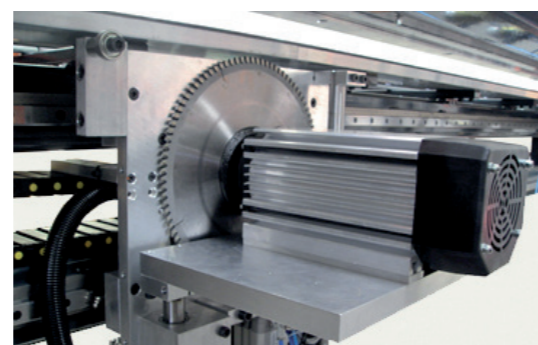
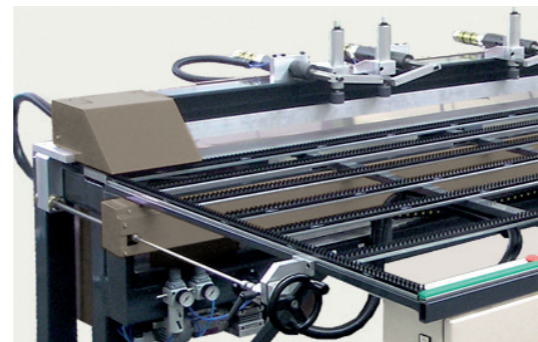

HP 601 and HP 620 are oil hydraulic crimping machines for aluminum profiles, their construction in cast iron and steel, makes them robust and reliable guaranteeing the quality of the crimping over time. Their easy adjustment makes the profile change fast thanks to special decimal height counters, the knife blocks are equipped with quick release and magnets to prevent them from falling.

HP 601 HP 620



TECHNICAL DATA	HP 601	HP 620
2 knives	3 mm	3 mm
2 knives	5 mm	5 mm
2 knives	7 mm	7 mm
1 wedge per pusher	20 mm	20 mm
1 wedge per pusher	30 mm	30 mm
Decade counter	N° 3	N° 3
Crimping power	6600 kg (14.550 lb)	6600 kg (14.550 lb)
Maximum workable height	120 mm	200 mm
Air consumption	19 NI/'	19 NI/'
Dimensions (WxDxH)	2.300x750x1.150 mm	2.300x750x1.250 mm
Weight	325 kg (716 lb)	345 kg (760 lb)

WSA

The WSA model is a milling machine for making slots for ventilation and water drainage on PVC profiles, with automatic cycle. It is equipped with three working units, two of which can work simultaneously on two sides of the profile. The oblique motor, which can be tilted from 30 to 60 degrees, is able to move automatically to the right or left as required by the operator simply by selecting a button.

These three high-frequency motors eliminate all forms of maintenance. The working cycle is managed by a PLC that allows speed of execution of the machining operations. No adjustments are required to switch from sash to frame machining of the same series of profiles, however, when changing series, the adjustments are easy and intuitive.



TECHNICAL DATA	WSA
Single-phase power supply	220 Volt - 50 Hz
Motor power	3 x 0.4 kW
Motor rotation speed	18.000 rpm
On board milling cutter	3x Ø 5mm
Air consumption	3 NI/”
Weight	112 kg (247 lb)

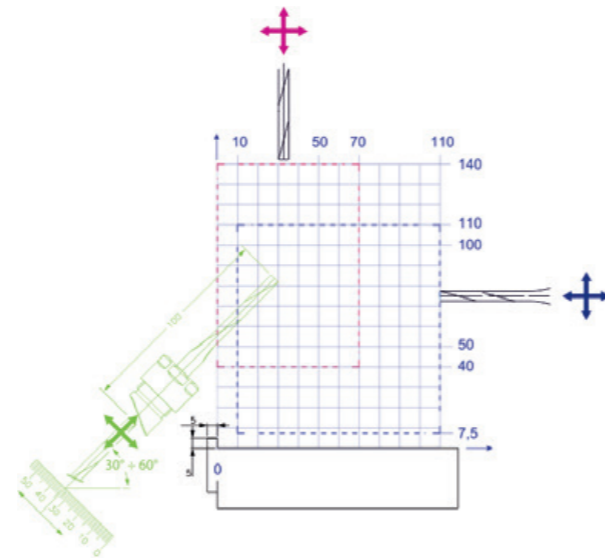

ML 142

The ML 142 model is a manual milling machine for making slots for ventilation and water drainage on PVC profiles. It is equipped with three working units, one oblique tilting up to 60° degrees, one horizontal and one vertical. The three working units are independent of each other, operated with a lever, and allow free milling of the profile in longitudinal direction.

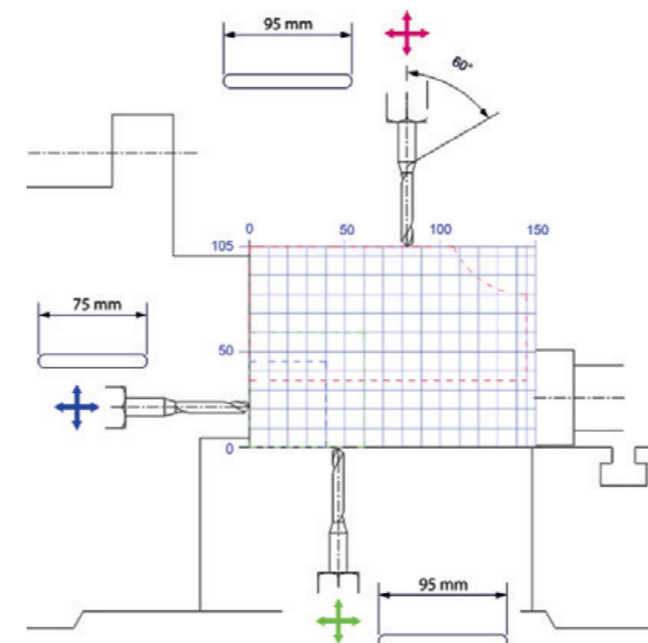
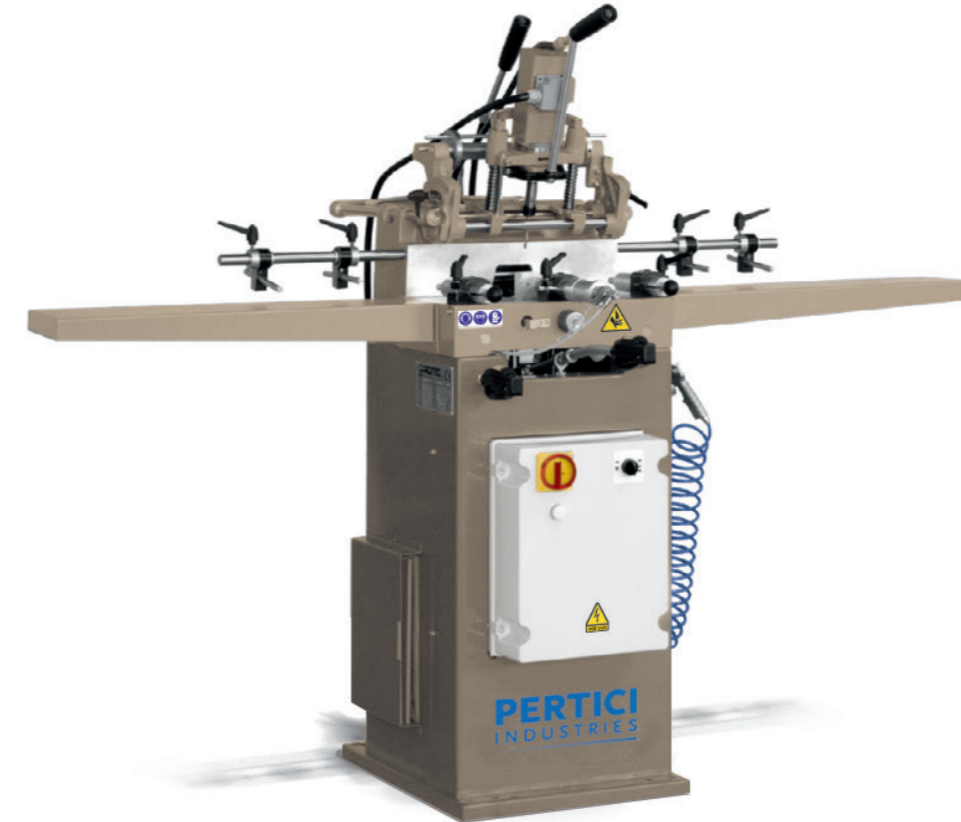

TECHNICAL DATA	ML 142
Single-phase power supply	220 Volt - 50 Hz
Motor power	3 x 0.4 kW
Motor rotation speed	18.000 rpm
On board milling cutter	3x Ø 5mm
Air consumption	3 NI/”
Weight	102 kg (225 lb)

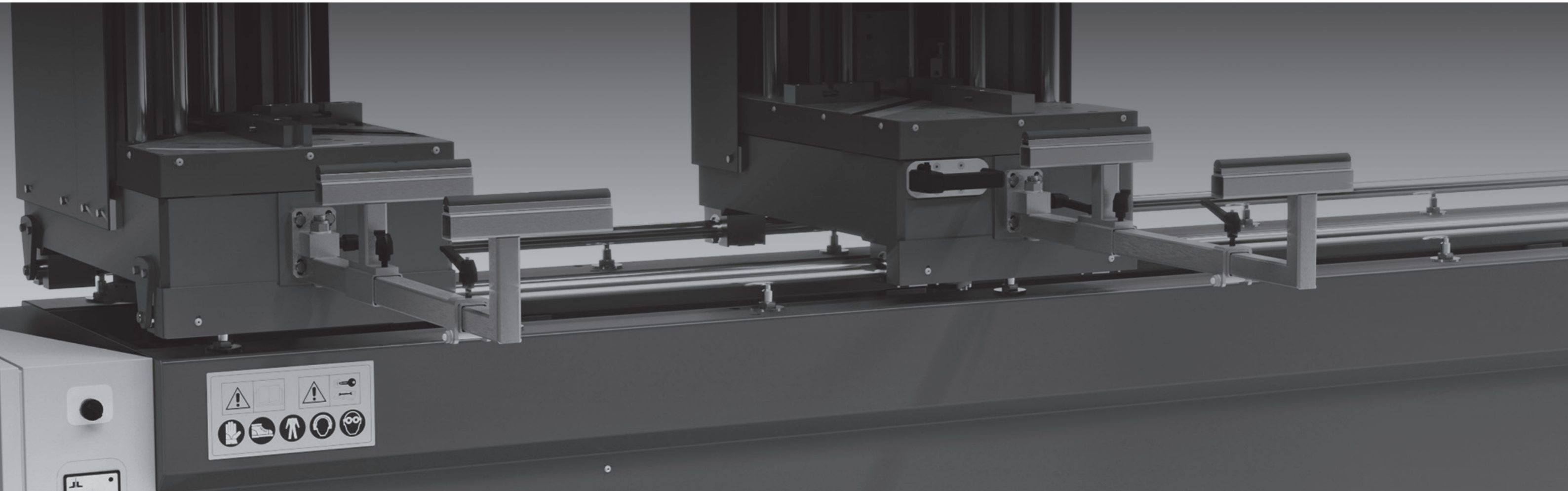

WELDING MACH. - CORNER CLEANERS - SCREW DRIVERS //

WM2

Two-head automatic welding machine with fixed head with variable angles from 40° to 180° and moving head with fixed angle at 90°. The WM2 is available in 3500 mm length, both heads are equipped with heated knives, heater plate with automatic temperature control by digital thermoregulator and standard limitation thickness at 0.2 mm.

The burn off is 3 mm for each welded side. WM2 can be equipped with profiles blocks (as an option) and can process all types of standard profiles, acrylic and coated. The whole welding cycle is controlled by PLC which manages heating, melting and cooling times.

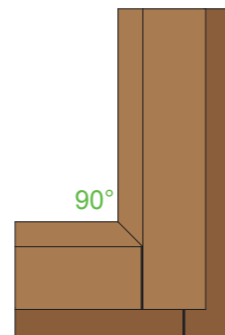
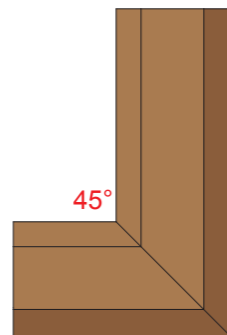
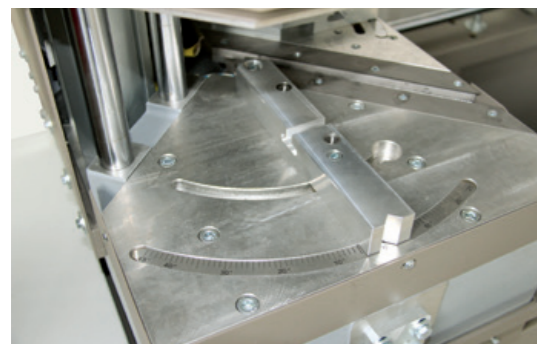
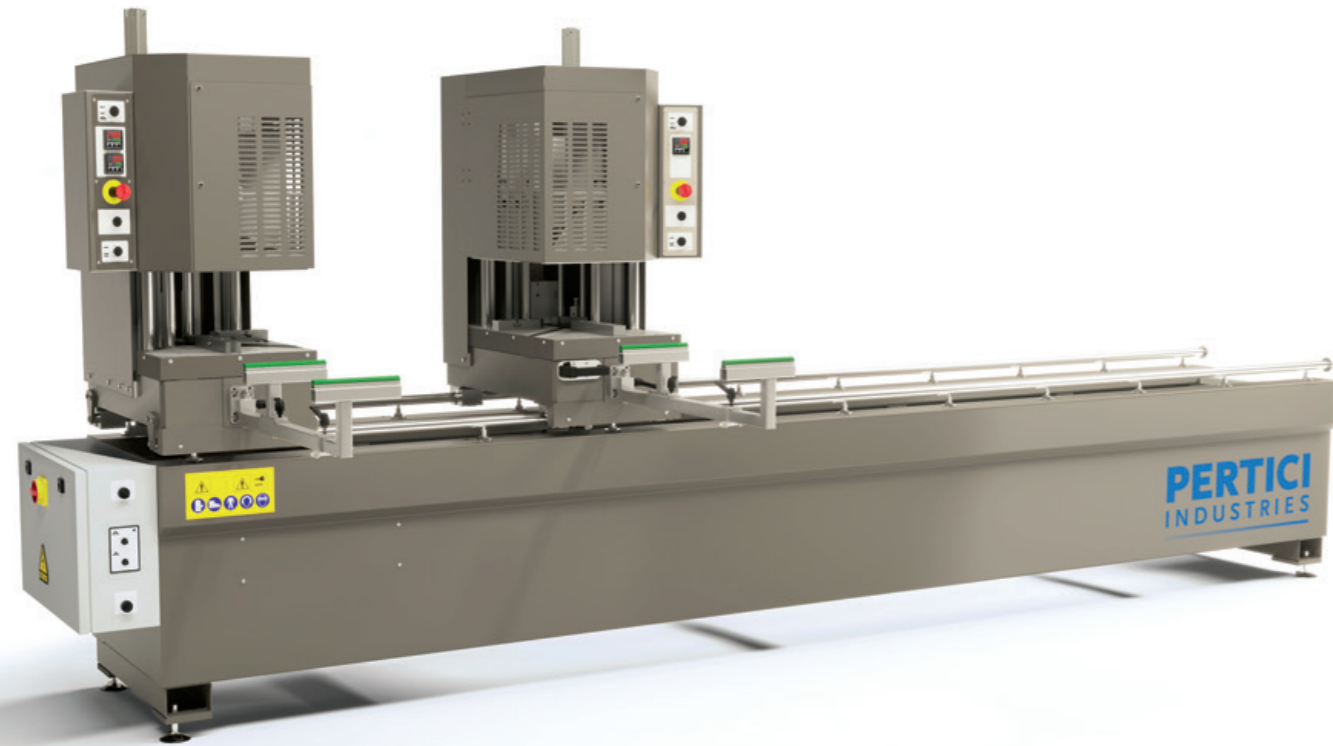

WM1

One-head automatic welding machine to weld angles at 90° and variable angles from 40° to 180°. The WM1 is equipped with heated knives, heater plate with automatic temperature control by digital thermoregulator and standard limitation thickness at 0.2 mm.

The burn off is 3mm for each welded side. The WM1 can be equipped with profiles blocks (as an option) and can process all types of standard profiles, acrylic and coated. The whole welding cycle is controlled by PLC which manages heating, melting and cooling times.

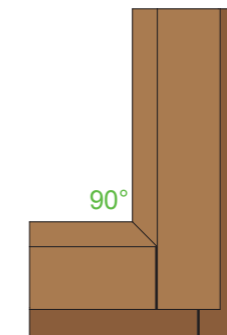
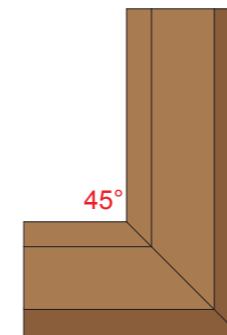
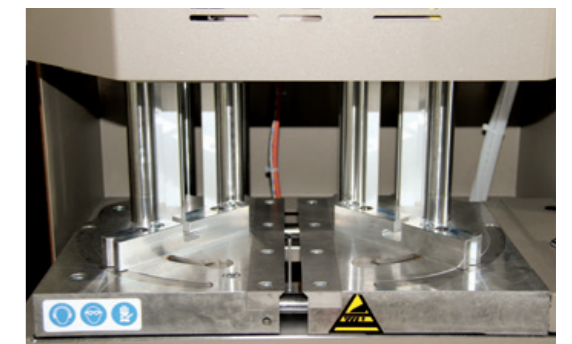

CM 170

CM 170 is a CNC cleaning machine with 2 interpolated axes with automatic cycle. It allows the complete cleaning of both the upper and lower welded angle. It can also process profiles of any shape: linear, radiused on the inside and outside. The machine can be equipped up to a maximum of 10 tools plus the disc cutter for external contouring, all the above mentioned tools are managed by the numerical control unit.

Thanks to a self-centering system, the knives compensate the profile tolerances and guarantee a high quality finish. The machine is equipped with an industrial PC for the management and graphic display of all working phases. If necessary, the CM 170 can be equipped for perfect cleaning of the most complex geometries or very delicate and difficult coatings such as acrylic.



TECHNICAL DATA	CM 170
Three-phase power supply	400 Volt - 60 Hz
Three-phase motor power	2.8 kW
Air pressure	7 bar
Workable profile width (mm)	50 - 130 mm
Workable profile height (mm)	50 - 115 mm
Dimensions (WxDxH)	2.600x2.750x1.850 mm
Weight	800 kg (1.763 lb)

CM 1S

The CM 1S automatic cleaning machine carries out the cleaning of the PVC corner weld bead by combining a cutter unit and two knives for the upper and lower part of the frame.

The specially shaped cutter units are equipped with a quick change to facilitate the changeover operation. The knives fit the surface of the profile thanks to a self-levelling system. The whole working cycle is coordinated by an internal PLC that controls the clamping of the welded frame and starts the cleaning cycle. CM 1S is equipped with two useful arms for the support and the management of the frame rotation. The machine, properly equipped with the necessary tools, can work all types of standard profiles, acrylic and coated.



Semi-automatic screwdriver with automatic screw feed for fixing the reinforcement for PVC profiles. A foot control starts the profile clamping and screwing. The machine body is mounted on a metal structure equipped with an infeed and an outfeed roller conveyor.

ASD 30



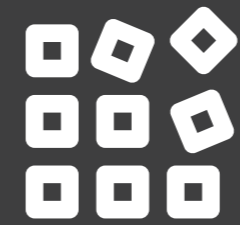
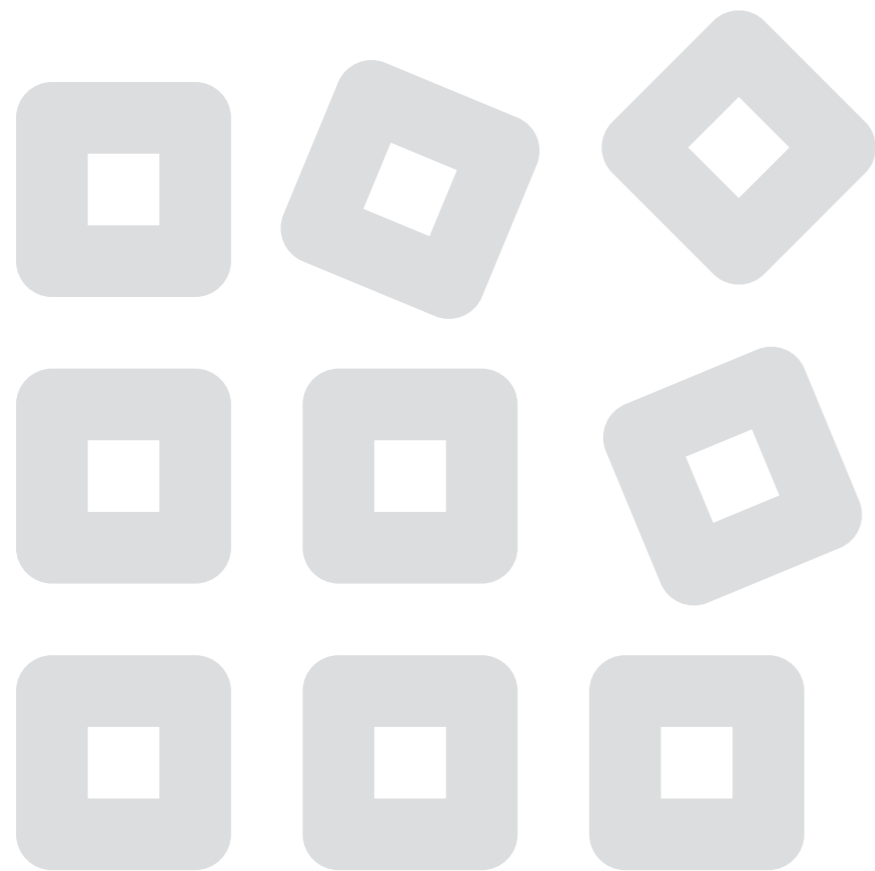
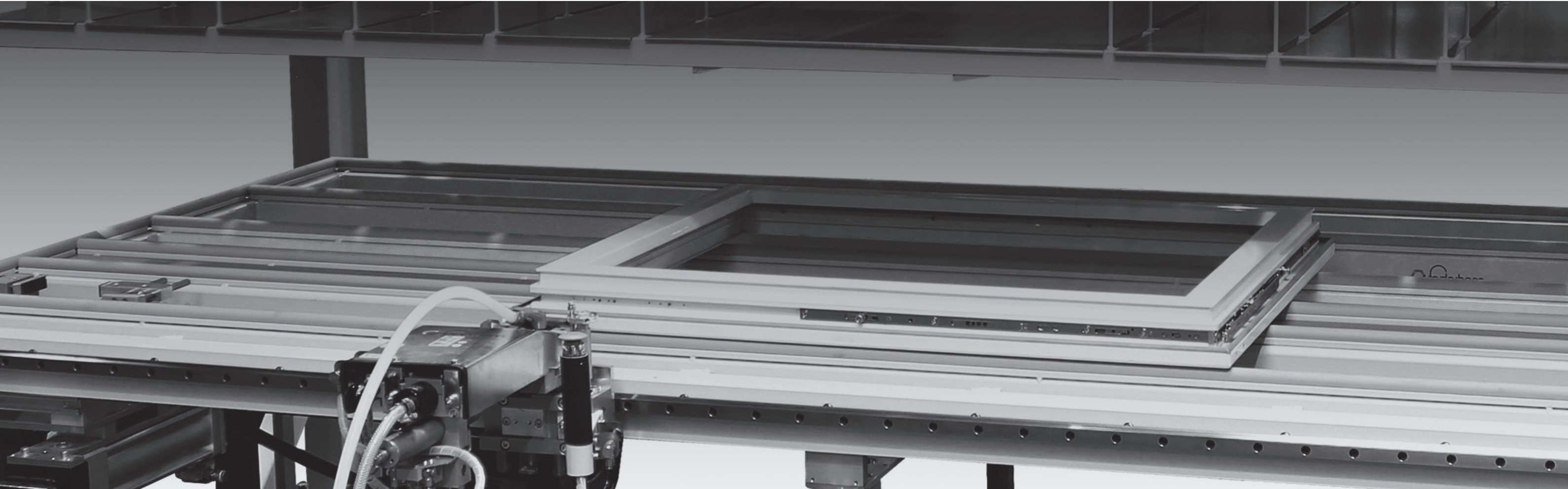

ASSEMBLY TABLES AND TROLLEYS //

BL VPPH

BL VPPH is a vertical bench for PVC windows suitable for the installation of the glass in the windows and doors and for the inspection of the frames. It works with self-centered system managed by pneumatic cylinders that move two clamping bars on the frame to be glazed.

The main structure has the possibility to be adjusted in height to ensure maximum working ergonomics even with modest dimensions of the window frame to be glazed. Moreover, the locking bars can be folded on the back to facilitate the sliding of the window frame along the machine base on rollers. BL VPPH is available in four versions 2.200, 2.800, 3.200, 4.200 mm wide and fixed height at 2.650 mm.



Assembly table for frames

- The worktop, of variable dimensions both in length and in width, is composed of six aluminium bars with rubber fittings on the support side.
- 4 spirals (length 7 m) complete with fittings.
- 6 containers.
- 4 quick couplings for compressed air.

Options

- Pneumatic screwdriver.
- Pneumatic drill.

BL 300



BL 3002

BL 3002 is a workbench dedicated to the hardware assembly. The structure is well dimensioned and allows to work large sashes. The frame slides on special anti-scratch guides and the locking system is self-centering.

As standard, the BL 3002 provides for the measurement of the hardware, the cutting of the hardware to size by shear and the screwdriver with its automatic screw feeder.

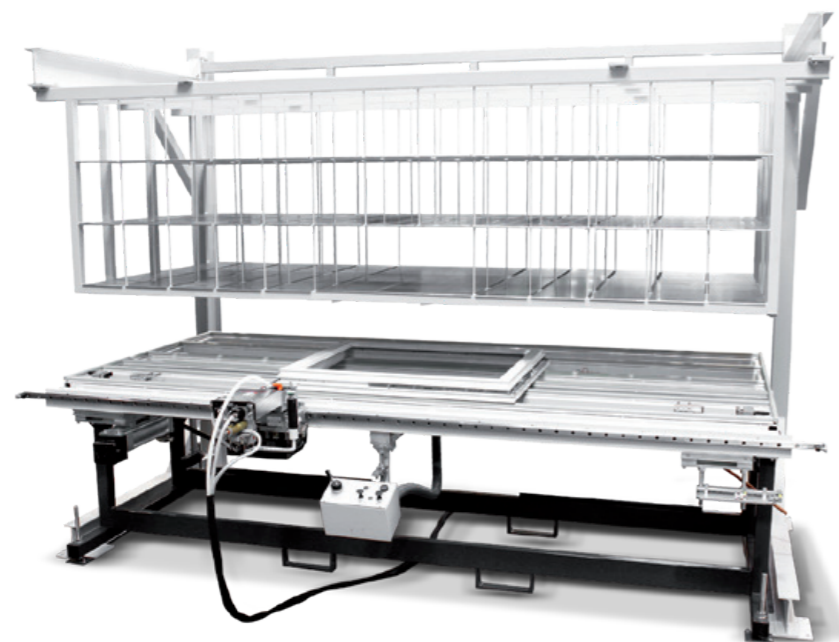

IRON BUSH

Trolley for horizontal profiles

- 5 housings.
- Support surfaces covered with PVC.
- Four wheels to facilitate the movement of the trolley, two of which have brakes.
- Dimensions (WxDxH): 1.600x900x1.800 mm.
- Weight: 60 kg (132 lb).
- Capacity: 450 kg (992 lb).



IRON END

Trolley for finished elements

- Support surfaces covered with PVC.
- Four wheels, two of which have brakes.
- Dimensions (WxDxH): 2.000x1.100x1.800 mm.
- Weight: 150 kg (330 lb).
- Capacity: 1.000 kg (2.204 lb).



IRON CAR

Trolley for vertical profiles

- 10 housings
- Support surfaces covered with PVC.
- Four wheels to facilitate the movement of the trolley, two of which have brakes.
- Dimensions (WxDxH): 1.200x900x1.800 mm.
- Weight: 65 kg (143 lb).
- Capacity: 450 kg (992 lb).



IRON WORTH

Complete window trolley

- Support surfaces covered with PVC.
- Knob to facilitate the movement of the trolley on four wheels, two of which have brakes.
- Dimensions (WxDxH): 1.650x1.200x1.800 mm.
- Weight: 74 kg (163 lb).
- Capacity: 450 kg (992 lb).



IRON STRONG

Trolley for vertical profiles

- 8 housings.
- Four wheels to facilitate the movement of the trolley, two of which have brakes.
- Dimensions (WxDxH): 900x600x1.350 mm.
- Weight: 50 kg (110 lb).
- Capacity: 400 kg (882 lb).



IRON CLEVER

Trolley for the hardware

- 12 housings.
- Surfaces covered with PVC.
- Four wheels to facilitate the movement of the trolley, two of which have brakes.
- Dimensions (WxDxH): 1.000x700x950 mm.
- Weight: 50 kg (110 lb).
- Capacity: 300 kg (661 lb).



IRON READY

Trolley for finished windows

- Support surfaces covered with PVC.
- Four wheels, two of which have brakes.
- Dimensions (WxDxH): 1.700x900x1.800 mm.
- Weight: 95 kg (209 lb).
- Capacity: 450 kg (992 lb).



IRON GASKETS

Gasket trolley

- 6 removable coils.
- Maximum diameter of the coil 550mm
- Quick reel change.
- Four wheels, two of them with brakes.
- Dimensions (WxDxH): 870x870x1.800 mm.
- Weight: 30 kg (66 lb).
- Capacity: 150 kg (330 lb).



IRON HELP

Profile support trolley

- Height adjustment from 750 mm to 1.250 mm
- Roller width 210 mm.
- Weight: 7 kg (15 lb).



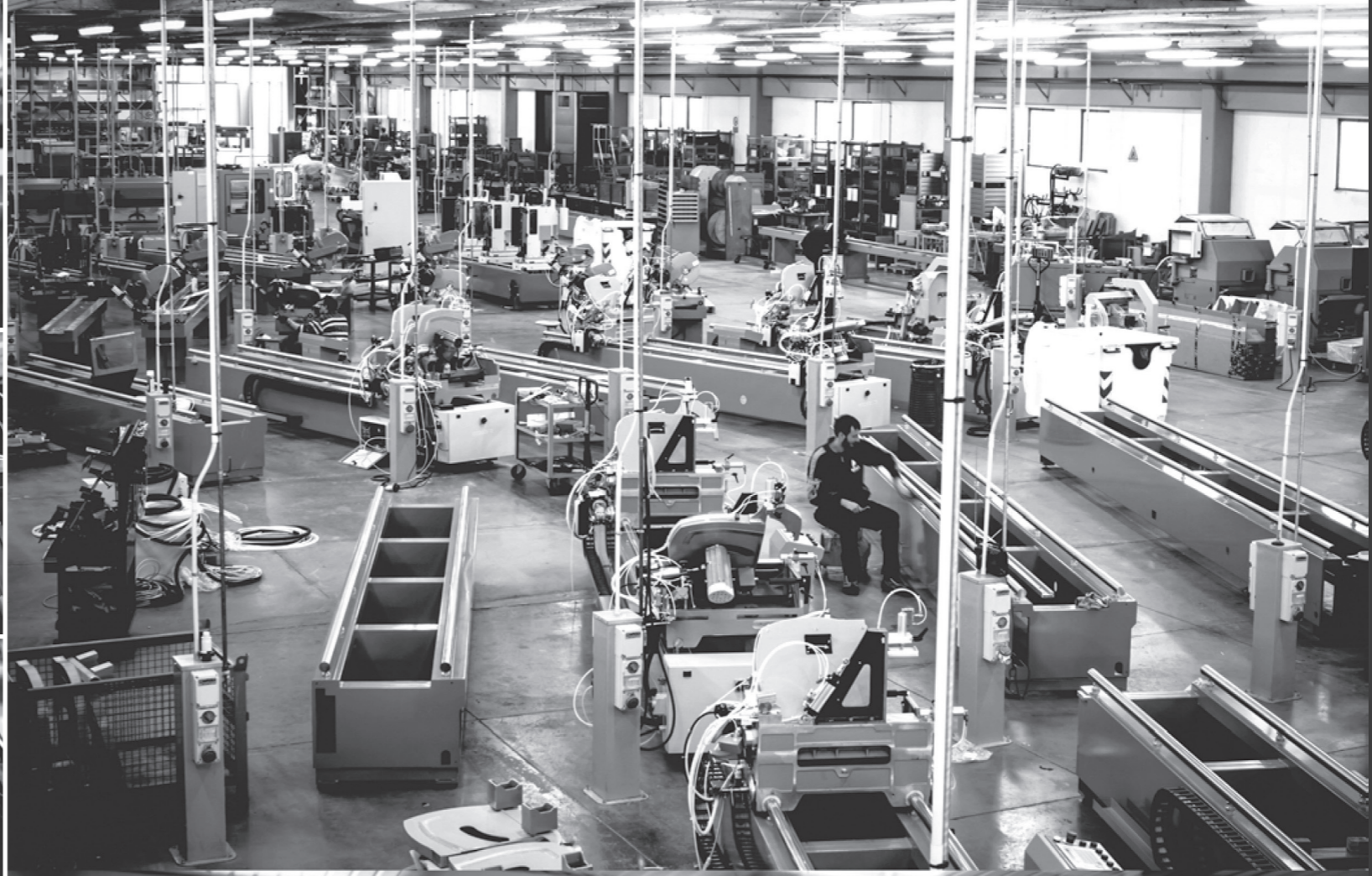
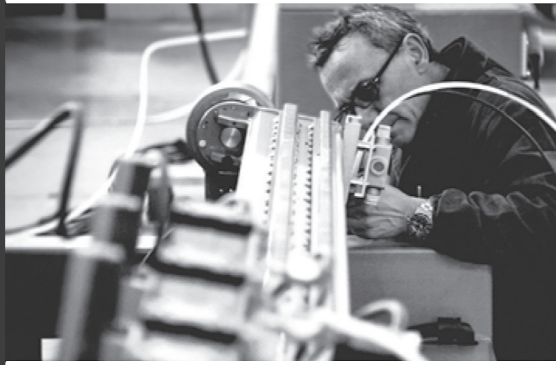

PERTICI[®]
INDUSTRIES

ООО «ПО ИП»
Тел: +7 (812)602-77-08
E-mail: info@poip.ru
www.poip.ru